VIC-3D

SOFTWARE MANUAL

Version 9.4

correlated
SOLUTIONS

Contents

1	Vic-3D Manual	5
1.1	Navigating the Online Help System	5
1.2	Quick Start	5
1.3	Getting More Help	6
1.4	Bug Reports and Feature Requests	6
1.5	What's New in Vic-3D 9.4	6
1.6	What's New in Vic-3D 9.2	7
1.7	What's New in Vic-3D 9	7
1.8	Transitioning from Earlier Versions	8
2	Overview	9
2.1	The Start Page	10
2.2	File Menu	11
2.3	Edit Menu	11
2.4	Project Menu	11
2.5	Calibration Menu	12
2.6	Data Menu	12
2.7	Plot Menu	12
2.8	Window Menu	13
2.9	Help Menu	13
2.10	Main Toolbar	13
2.11	Animation Toolbar	14
2.12	Other Functionality	15
3	Projects in Vic-3D	17
3.1	Project Organization	17
3.2	Creating a New Project from a Template	18
3.3	The Project Tool Box	18
4	Speckle and Calibration Images	25
4.1	Adding Speckle Images	25
4.2	Adding Calibration Images	25
4.3	Working with Images	27
4.4	The Reference Image	28

5	Calibration	37
5.1	Stereo Calibration	37
5.2	Hybrid Calibration	43
5.3	Separate Calibration	50
5.4	Calibrating an External Camera	53
5.5	Adjustments for Cropping	57
5.6	Importing a Calibration	58
6	Initial Guess Selection	59
6.1	Placing Start Points	59
6.2	Editing Initial Guesses	60
6.3	Initial Guesses from Corresponding Points	60
6.4	Initial Guesses from Subset Controls	61
6.5	Comparison View	63
7	Running the Correlation	65
7.1	The File Tab	65
7.2	The Options Tab	65
7.3	The Thresholding Tab	71
7.4	The Post-Processing Tab	72
7.5	The Multi-System Tab	73
7.6	Correlation Results	74
7.7	Troubleshooting Analysis	76
8	Batch Processing Dialog	79
8.1	Queuing Projects	79
8.2	Batch Analysis	80
9	Coordinate Systems and Transformations	81
9.1	Coordinate System Selection	82
9.2	Applying Coordinate Transformations	84
9.3	Cylindrical Coordinate Transformations	86
9.4	Coordinate Systems Registration	88
10	Postprocessing Tools	97
10.1	Strain Calculation	97
10.2	Removing Rigid Motion	100
10.3	Applying Functions to Data	102
10.4	Restoring/Retriangulating Data	109
10.5	Calculating Velocity	110
10.6	Curvature Calculation	111
10.7	Rotation Calculation	112
10.8	Smoothing Data	114
10.9	Mapping External Data	115
10.10	Deleting Variables	118

10.11	Time Filter	119
10.12	Time Averaging Data	122
10.13	Combining Data	124
10.14	Math Operations	127
11	Exporting Data	131
11.1	Exporting All Data	131
11.2	Exporting Grid-Based Data	133
11.3	Extracting Node Data	134
11.4	Calculating Statistics	137
12	Plotting Data	139
12.1	Output Variables	139
12.2	The Plot Toolbox	141
12.3	3D Plots	145
12.4	2D Plots	147
12.5	Exporting Videos	150
12.6	Extraction Plots	152
12.7	Complex plot extractions	160
13	Data Visualization in <i>iris</i>	165
13.1	Overview of the <i>iris</i> Workspace	165
13.2	Pages, Templates and Backgrounds	169
13.3	Graphic Elements	177
13.4	Working with Sequences	204
13.5	Working with Keyframes	208
13.6	Document Properties	212
13.7	Exporting <i>iris</i> Content	215
14	Report Generation	221
14.1	Report Generator Dialog	221
14.2	Report Options	221
14.3	Template Tag Reference	223
15	Marker Tracking	229
15.1	Placing Markers	229
15.2	Tracking	230
15.3	Marker Triangulation	233
15.4	Marker Visualization in <i>iris</i>	234
15.5	Exporting Marker Data	234
15.6	The Files Tab	235
15.7	The Markers Tab	235
15.8	The Variables Tab	235
16	FFT Analysis	237
16.1	The Frequency Analysis Dialog	237

16.2 Frequency Workspace	239
17 Real-Time Analysis	249
17.1 Calibration in Real-Time Mode	249
17.2 Selecting a Reference Image	250
17.3 Running the Analysis	250
17.4 Analysis Options	250
17.5 Pausing the Analysis	250
17.6 Notes	251
18 Stereo Microscope Analysis	253
18.1 Calibrating Distortions	253
18.2 Stereo Calibration	253
18.3 Analyzing Speckle Images	254
19 Batch Processing Mode	259
20 VicPy Python Module	261
20.1 Installation	261
20.2 Example	263
20.3 Class Reference	265
21 Licenses	273
21.1 Qt License	273
21.2 Ffmpeg License	277
21.3 LibTiff License	281
21.4 VTK License	281
21.5 ZLib License	282
21.6 MuParser License	283

Chapter 1

Vic-3D Manual

1.1 Navigating the Online Help System

This document is also available in the Vic-3D software and can be accessed by selecting the *Help* menu entry. This will open up a help window to view the documentation. The help viewer provides a contents tree view that can be expanded and collapsed to navigate the sections of this manual. Double-clicking on items in the content tree will display the corresponding page. Furthermore, a keyword search is provided in the *Index* panel and a full-text search can be accessed by clicking on the *Search* tab.





Context-sensitive help is available for many dialogs by pressing the **F1** key while the dialog is active. This will automatically display the corresponding section in the manual.

 Vic-3D uses context menus that can be activated by right-clicking on many user interface elements (lists, image views, plots etc.) to provide quick access to common functions. Before searching the help, a right-click may reveal how to access the sought for functionality.

1.2 Quick Start

There are only a few steps involved in obtaining shape and deformation measurements from your images. If you do not have any image data yet, you can find a complete example project in the *examples* folder in the Vic-3D installation directory. The example project is located in the subfolder *membrane* and may also be found in the *Start Menu* folder.

The basic workflow can be summarized in the following steps:

1.  Adding [calibration images](#) to the project.
2.  [Calibration](#) of the stereo system.
3.  Importing [speckle images](#) and selecting a [reference image](#)
4. Definition of an [area of interest](#) for analysis.
5.  [Analyzing](#) the images to obtain shape and displacement data.

6. Plotting the results.

For the example project, the above steps should result in a data plot similar to the one shown in Fig. 1.1.

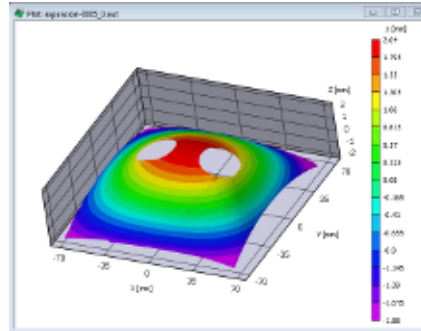

Figure 1.1: Vic-3D example project.

1.3 Getting More Help

If you cannot find an answer to your question in this manual, please do not hesitate to contact our technical support at support@correlatedsolutions.com. You can also find contact information at our web site at www.correlatedsolutions.com.

We will be happy to assist with topics such as:

- Designing digital image correlation experiments
- Calibration
- Troubleshooting errors
- Interpreting test data
- Achieving optimal results

1.4 Bug Reports and Feature Requests

If you encounter a bug in Vic-3D, please let us know about it. Send a short description of the problem to support@correlatedsolutions.com along with any project or image files you think may help us reproduce the bug.

Also, if you think Vic-3D can be improved by adding a particular feature you would find helpful, let us know about it. We will try to incorporate your requests in our future updates of the software.

1.5 What's New in Vic-3D 9.4

The 9.4 release of Vic-3D contains enhancements to marker tracking and point/marker visualization, as well as FFT improvements.

- PDF export now supports automatic generation of pages for multiple timesteps
- Velocity computation in FFT
- New dialog for batch processing with automatic report generation
- Export area FFT data to Universal File Format (UFF)
- Velocity and acceleration calculation for markers
- Visualization for marker trajectories in *iris*
- Visualization of locations and trajectories of extraction points in *iris*
- Customizable marker/extraction labels with escape codes for inserting data

1.6 What's New in Vic-3D 9.2

The 9.2 release of Vic-3D contains a number of enhancements to marker tracking and visualization tools.

- Advanced marker tracking with velocity and acceleration computation
- Markers may be connected to create structures and parts
- New visualization tools in *iris* for markers and connections allow animation of moving points, parts, and mechanisms
- High-resolution vector rendering in 2D and 3D data plots in *iris*
- Multiple data sources can be present in one *iris* plot allowing display and animation of mixed full-field and marker data

1.7 What's New in Vic-3D 9

The all-new Vic-3D Iris graphics engine brings a host of new functionality to the already versatile Vic-3D software. It delivers extremely high resolution still and moving images with multiple page PDFs or MP4 presentations, all from within. Some of these exciting new features are listed below:

- Create multiple-page, high-resolution, publication-ready plots in PDF and ultra-high-definition video formats (from 720p to 4K)
- View high-resolution isolines on [2D](#) and [3D plots](#) with scalable fonts
- Edit labels with Unicode support
- View speckle images on 3D plots
- All new user-friendly graphics engine for animating object position, scale, opacity, rotation, and much more
- Create high-quality videos using the multi-threaded rendering engine (see [iris export](#))
- Create life-like animations using integrated adaptive motion blurring for fast-moving objects
- Animate object position, scale, opacity, rotation, and much more with an all-new user-friendly graphics engine
- Import Finite Element data for visualization and comparison to measurement data into new graphics framework
- Corrected Von Mises Strain scaling factor

1.8 Transitioning from Earlier Versions

- In the Calibration dialog, instead of selecting **High magnification** or **Distortion order** directly, specify or create the appropriate *Imaging system*, see [Section 5.1.6](#).
- Rather than directly exporting marker data, you will first triangulate the data, and then export. See [Section 15.3](#).
- If you have a complex calibration in your project, you will not be able to open it in earlier versions of Vic-3D.
- Starting with version 7, Vic-3D uses a new model for start points which is a bit different than the seed point used in previous versions.
 - Not every AOI will have a start point. In many cases you can just draw the AOI and run immediately.
 - You can now draw multiple start points. They will be analyzed in parallel and analysis will proceed outwards from each one at the same time.
 - Start points are no longer associated with a specific AOI; they can be placed in overlapping AOIs, or completely off the AOI. Start points which are too far from an AOI will not be used for anything.

Chapter 2

Overview

The user interface of Vic-3D has many of the familiar control elements found in other applications. The user interface is illustrated in Fig. 2.1. The most commonly used functions can be accessed by clicking on tool buttons on the **Tool Bar**. The windows, such as the **AOI Editor** and **Plot** windows are grouped inside a **Workspace**. The **List View** on the left of the main window provides a quick overview of image and data files.

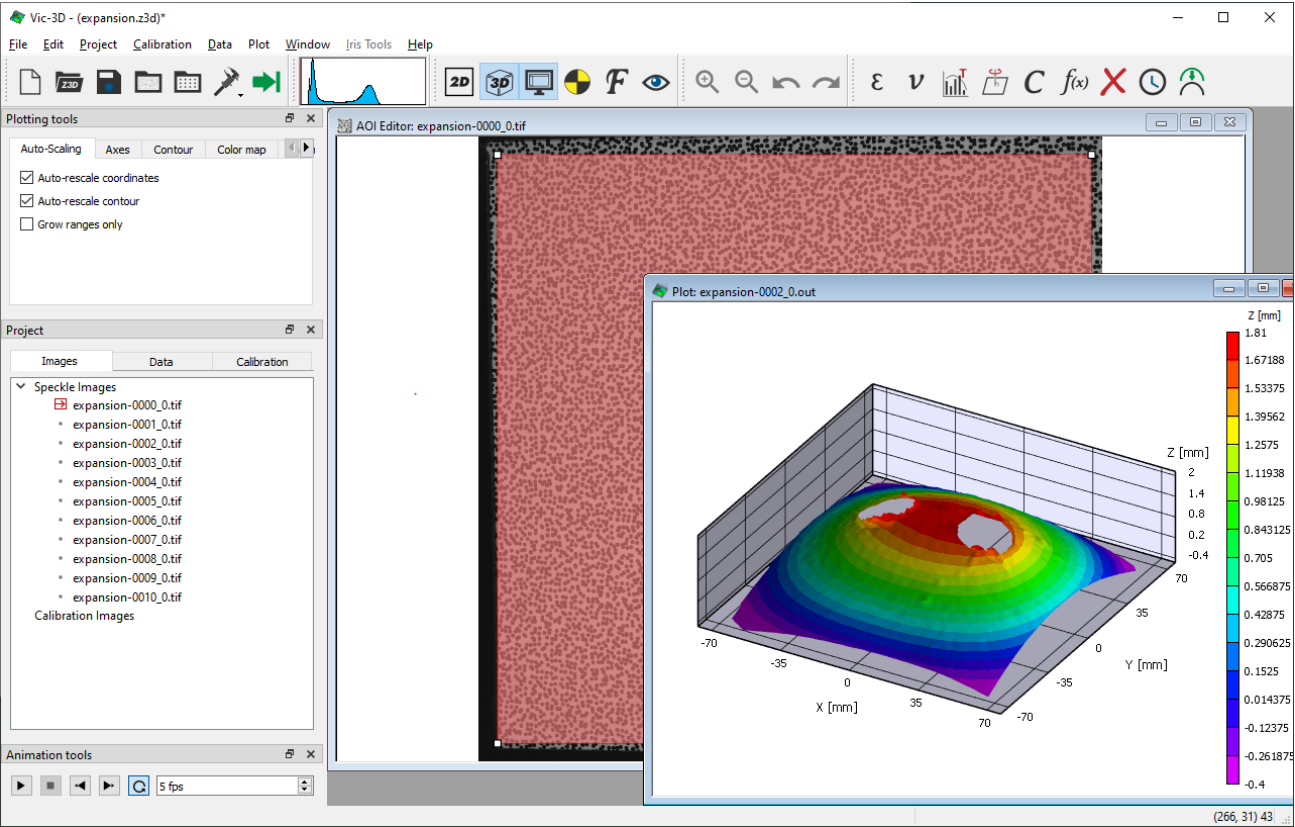

Figure 2.1: Vic-3D Application Window

2.1 The Start Page

The start page in Vic-3D gives convenient access to frequently-used tasks and recent projects as illustrated in Fig. 2.2.

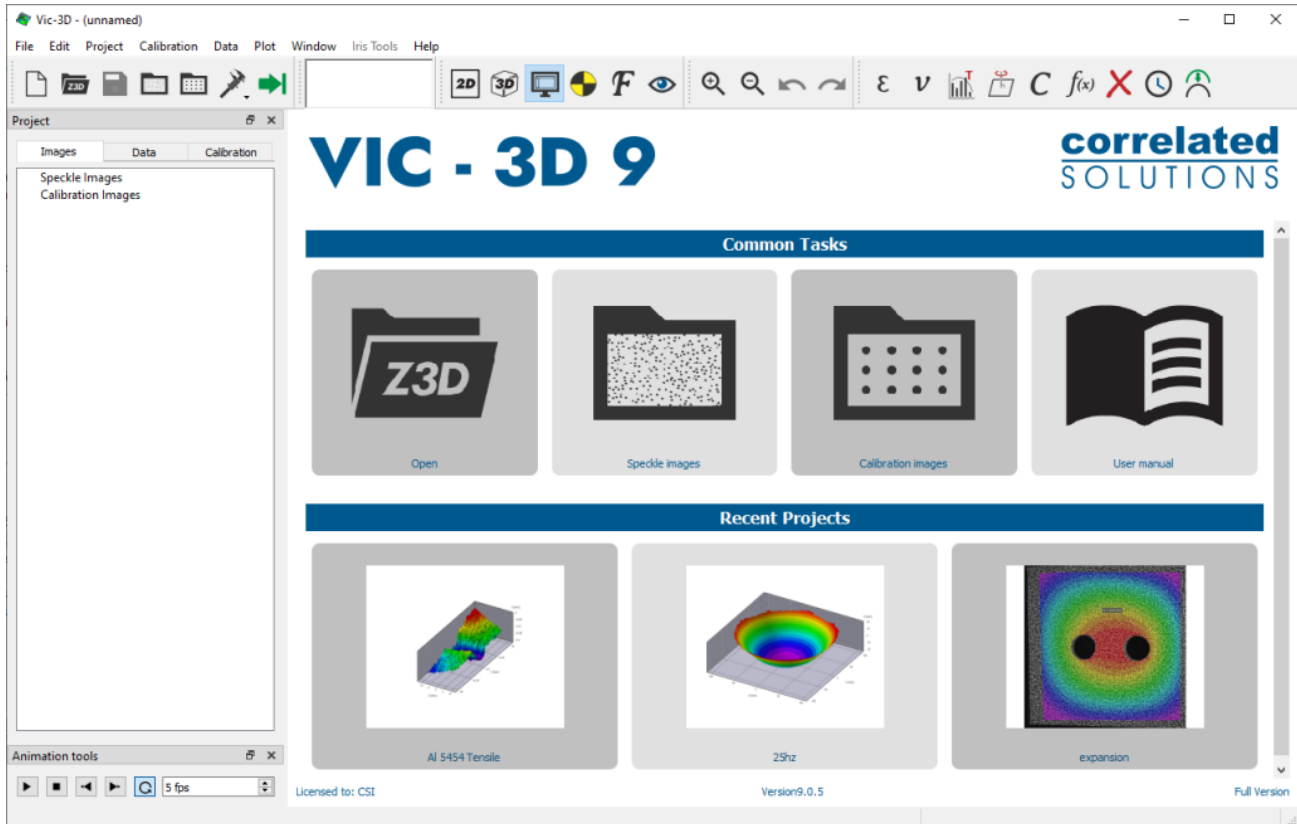

Figure 2.2: Vic-3D start page.

The **Common Tasks** section shows frequently used tasks that are also accessible from the menu bar. The task icons can be clicked to quickly open a project, add speckle or calibration images, or view this user manual.

The **Recent Files** section of the start page contains a list of the most recently accessed projects. Clicking on an icon opens the corresponding project. Note that hovering the mouse over an icon cycles through the preview icons contained in the project, which can help to distinguish similar projects more easily.



A longer list of recent project files can be accessed from the *File->Open recent* menu. While the mouse hovers over a recent project icon or menu entry, the full path to the project is shown in the status bar at the bottom of the main window. This is helpful to distinguish projects with identical names (which, of course, should be avoided...).

2.2 File Menu

The *File Menu* provides the following functions:

- **New** - creates a new project
- **New from template** - creates a new project using selected elements of an existing one
- **Open** - open an existing project
- **Open recent** - select from recently accessed projects
- **Save** - save the current project
- **Save As...** - save the current project under a new file name
- **Report** - generate a report using a selected template
- **Mode** - select a Vic-3D project type (3D, realtime, stereomicroscope, etc)
- **Install module licenses** - use this menu entry to activate software modules. This dialog displays the license key codes and current module licenses installed. When contacting support with questions regarding your license, it is advised to include your license codes and current installed modules on the license by clicking *current keys*
- **Quit** - closes Vic-3D



If the project has not been saved after changes have been made, an asterisk will appear next to the project name in the title bar of the window.

2.3 Edit Menu

The *Edit Menu* provides the following functions:

- **Undo** - undo the last editing operation in the reference image
- **Redo** - redo the last editing operation in the reference image
- **AOI tools** - each AOI tool is selectable from this menu.

2.4 Project Menu

The *Project Menu* provides the following functions:

- **Speckle images**- adds [speckle images](#) to the project for analysis
- **Calibration images** - adds [calibration images](#) to the project
- **Speckle image groups** - add a group of speckle images from the selected folder which contain the same prefix
- **Calibration image groups** - add a group of calibration images from the selected folder which contain the same prefix
- **Data files** - adds pre-existing output data files (.out) to the project
- **Analog data** - adds analog data files from Vic-Snap (.csv)
- **Workspace** - displays the 3D image correlation workspace

- **Marker editor** - displays the marker tracking toolset
- **Show FFT workspace** - works with frequency-domain data, bringing up the FFT calculation dialog if necessary. This module is only visible if purchased.

2.5 Calibration Menu

The *Calibration Menu* provides the following functions:

- **Calibrate stereo system** - calibrates the cameras and stereo rig simultaneously, see [Section 5.1](#)
- **From project file** - imports a calibration from an existing Z3D or V3D project file
- **Autocorrect calibration** - corrects for a disturbed camera orientation calibration, see [Section 5.3.4](#)
- **Adjust for cropping** - adjusts for differently sized calibration vs. speckle images (commonly used with stereo images from high-speed cameras or clipped images from a low speed system). See [Section 5.5](#) for details.
- **Calibrate camera 1 / 2** - calibrates camera intrinsic parameters separately (generally used for large scale calibration or troubleshooting camera synchronization). For details, see [Section 5.3](#).
- **Calibrate camera orientation** - calibrates stereo transformation from disparity data, see [Section 5.3.3](#).
- **Calibrate external camera** - calibrate for overlay of auxiliary camera data (i.e., from an infrared camera), see [Section 5.4](#).

2.6 Data Menu

The *Data Menu* provides the following functions:

- **Start analysis** - shows the [Run dialog](#) to begin 3D analysis
- **Postprocessing tools** - shows a submenu to choose from various [postprocessing calculations](#)
- **Coordinate tools** - shows a submenu to allow [coordinate system](#) manipulation
- **Markers** - allows exporting or fitting coordinates to marker data
- **Export** - various options for [exporting](#) full data set or reductions

2.7 Plot Menu

The *Plot Menu* provides the following functions:

- **New plot**- adds a new plot window to the work space
- **2D Plot**- changes the currently selected plot to 2D overlay mode
- **3D Plot**- changes the currently selected plot to 3D plot mode
- **Inspector**- allows choice of various data inspection tools

2.8 Window Menu

The *Window Menu* provides the following functions:

- **Cascade** - organizes all MDI windows in a cascade
- **Tile** - tiles all MDI windows

2.9 Help Menu

The *Help Menu* provides the following functions:

- **User manual** - show this manual.
- **About** - show version information.

2.10 Main Toolbar

The main toolbar (see Fig. 2.3) contains commonly used tool buttons to provide quick access to functionality without having to navigate through menus. A tool tip for each button can be shown by moving the mouse cursor over a button and waiting for a short amount of time for the tip to pop up. This also displays a description of the tool button in the status bar of the application at the bottom.



Figure 2.3: The main toolbar.

The toolbar contains the following buttons, from left to right:

File tools:

- New project (CTRL+N)
- Open project (CTRL+O)
- Save project (CTRL+S)
- Add speckle images
- Add calibration images
- Calibrate stereo system
- Start analysis (CTRL+R)

Plotting tools:

- Histogram control
- Switch to 2D plot/3D plot
- Show main Workspace
- Show Marker workspace
- Show FFT workspace (when module is present)

- Zoom in/out
- Undo/redo

Postprocessing tools:

- Calculate strain (CTRL+U)
- Calculate velocity
- Time filter data
- Calculate in-plane rotation
- Calculate curvature
- Apply a custom function
- Remove variables
- Retriangulate data
- Remove rigid motion

The histogram control displays the gray level distribution for the currently displayed image. The red bars on the histogram may be used to adjust the image display. Double-click on the histogram to automatically adjust the balance, or drag the red bars to set the black and white levels manually. Double click again to remove the balance adjustment.

The balance control is for display only and does not affect image analysis or stored images.

2.11 Animation Toolbar

The buttons on the animation toolbar allow stepping through and animating image files or plots.



Figure 2.4: Animation toolbar.

The controls, from left to right:

- **Play** - begins automatically stepping through images/plots.
- **Stop** - stops the animation.
- **Step Back/Step Forward** - goes to previous or next image/plot.
- **Loop** - toggles between looping from last image to first, and bouncing from forward to backward animation.
- **Frame rate** - selects the speed of the animation..

2.12 Other Functionality

In the right corner of the status bar at the bottom of the main window, the cursor position and image grey value is displayed when the mouse is moved inside the reference image or a deformed image. For 2D plots, this area will show the 3D coordinates as well as the value of the current contour variable. On the left side of the status bar, a short description of tool buttons and menu items is displayed when the mouse moves over them.

In the list view on the left side of the main window, some functions can be activated by right-clicking. Details can be found in the appropriate sections of this menu.

Chapter 3

Projects in Vic-3D

In Vic-3D, all the filenames and information associated with a test are stored in a *project*. Initially, projects are blank. Before running a Vic-3D analysis, the project must contain:

- One or more [speckle images](#), including a [reference image](#)
- A [calibration](#)
- One or more [areas of interest](#)

Note that the calibration can either be imported from another project file or generated by adding calibration images to the project to determine the calibration parameters. When a Vic-3D analysis is run, the output files (*.out) are stored on disk and added (by reference) to the project and displayed in the *Data* tab.

In addition to the items above, analog data files from Vic-Snap (*.csv) can be added to the project file. The analog data is then available for [extraction](#).

 All images, data files, and CSV files are only stored by *reference* in the project file. The original files must remain on the disk.

3.1 Project Organization

It is recommended that all image files are stored in the same folder as the project file. While it is possible to save project files in any directory, this may lead to problems if either the project file or any of the linked resources, such as image files, are moved. With project files in the same directory as image files, a project can be copied by simply copying the entire folder. This makes it easy and convenient to backup projects or move them from one computer to another.

Note that aside from image and data files, other imported items such as the calibration or coordinate transformations do not need to come from resources located in the same directory.

3.2 Creating a New Project from a Template

Vic-3D 8 allows you to create a new project by bringing in elements of an existing project, in order to streamline repeated tests. To begin, select *File... New From Template* from the main menu, or press Ctrl-Shift-N.

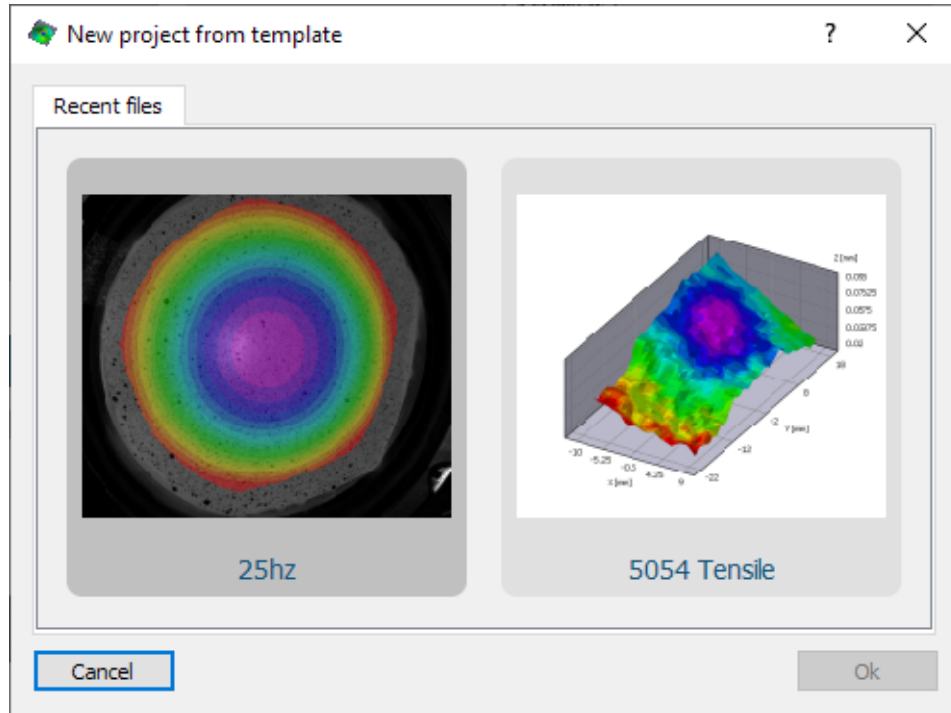

Figure 3.1: Project template dialog.

You will see a list of recent projects with previews. Single-click to select a project or mouse over to see a more detailed preview.

Select the elements you wish to import, and click the **Ok** button. A blank project will be created and you can now add images. If the template contains an AOI and it was imported, it will automatically appear as soon as a reference image is selected. Note that Vic-3D allows moving an entire AOI to account for small position differences. An AOI can be moved by clicking on a selected AOI and dragging it to the desired position.

3.3 The Project Tool Box

The project tool box is displayed at the left side of the work area by default. The tool box has three panels, one each for *Images*, *Data* and *Calibration*. The view can be switched between panels by clicking on the corresponding tab at the top of the tool box.

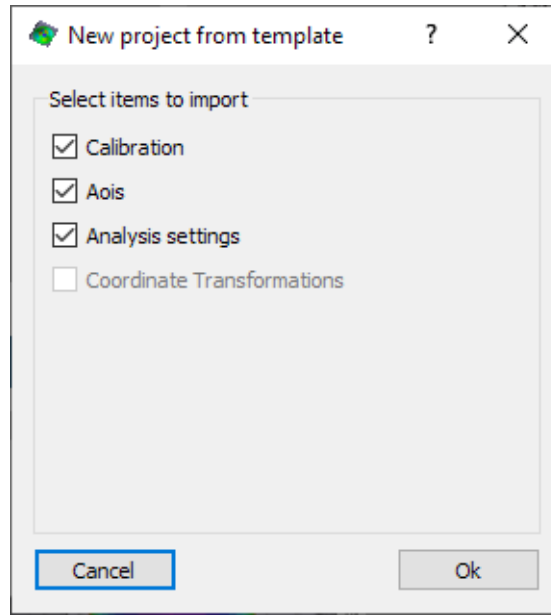

Figure 3.2: Template items available for import.



On the image and data tabs, a right-click shows a context menu with various actions that can be performed, e.g., animate, export etc. Single items can be selected by mouse-click, and extended selections can be performed by holding the **SHIFT** or **CTRL** keys while clicking on additional items. If a selection is present, the **Delete** or **Backspace** keys can be used to remove the selected items from the project.

3.3.1 The Images Panel

The images panel shows all speckle and calibration images associated with the project. Note that Vic-3D always displays the file names corresponding to the first camera.

To add speckle images, select *Images... Speckle images* from the menu bar, or click the speckle images icon on the [main toolbar](#). The small red arrow indicates the reference image; to set an image as the reference, right click and click *Set as reference*.

To add calibration images, select *Images... Calibration images* from the menu bar, or click the calibration images icon on the [main toolbar](#).

To remove an image or series of images, select them, right click, and click *Remove* or *Remove selected*.

3.3.2 The Data Panel

The data panel lists all output data generated by Vic-3D as well as any analog data acquired with Vic-Snap. The file names of the output files generated by Vic-3D correspond directly to the image file names and differ only in the extension.

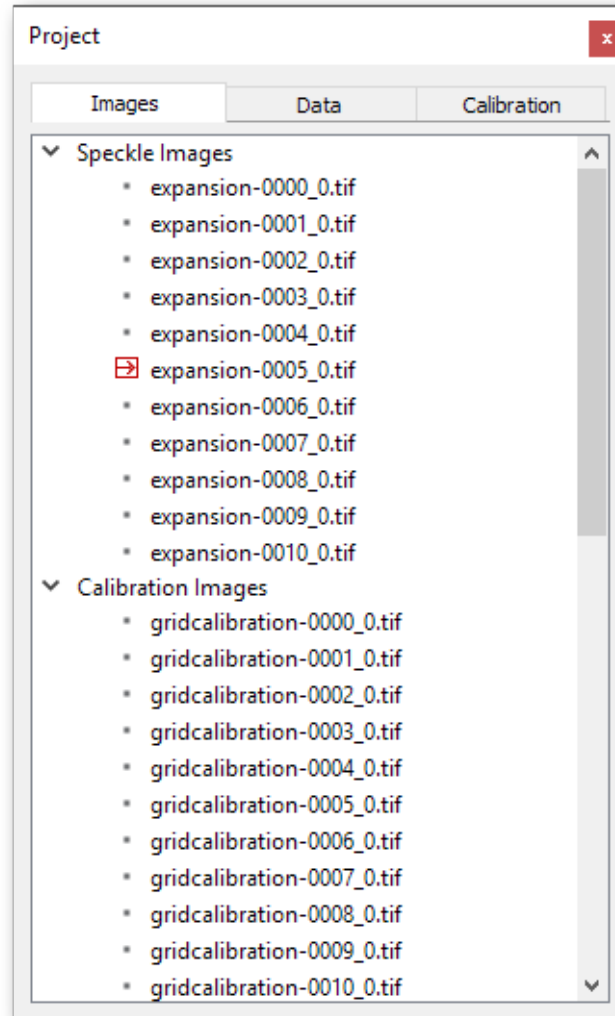

Figure 3.3: Project toolbar files tab.

All generated output files are added to the *Current data* list. Output files not associated with current speckle images are added to *Other data*. Double-click on a data file to view a 3D plot.

Analog data from Vic-Snap is listed under *Analog data*. To add an analog data file, select *File... Add Files... Add Data Files* from the main menu. To view a spreadsheet of the data, double-click the filename.

All plot extractions are listed under [Extraction data]

Generated video files from 2D and 3D animations are added to the *Video files* list. Double-click on a video to display it in an external viewer.

3.3.3 The Calibration Panel

The calibration panel displays the current calibration information for the project. The calibration panel does not permit editing the calibration values and merely displays the results of the

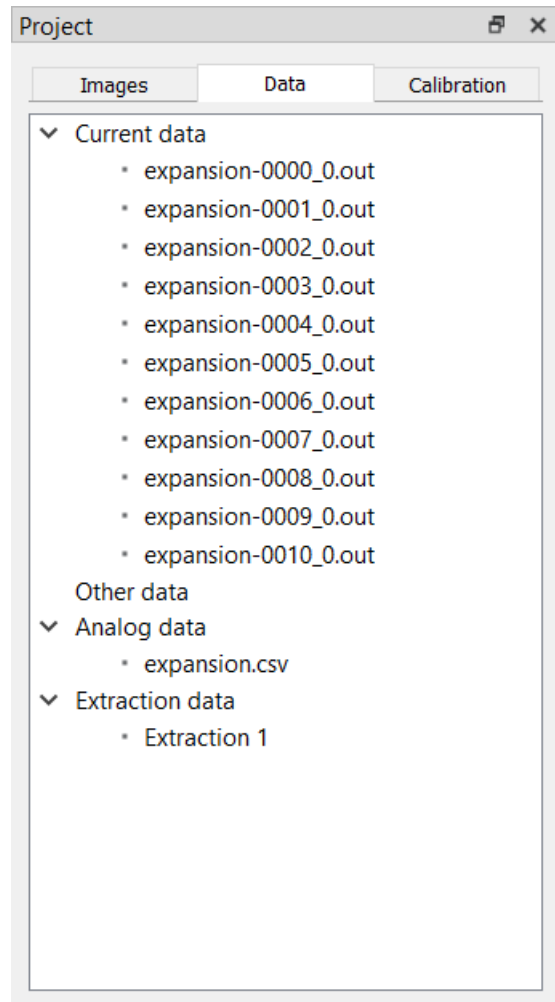

Figure 3.4: Project toolbar data tab.

The screenshot shows a window titled "Analog Data: expansion.csv" containing a spreadsheet. The spreadsheet has six columns: "Count", "Time_0", "Time_1", "Load", and "Ex". The data is organized into rows corresponding to expansion files. The first row is highlighted with a dotted border.

	Count	Time_0	Time_1	Load	Ex
expansion-0000_0.tif	0	0	-0.0004	10412.3	0
expansion-0001_0.tif	1	5.9995	5.9999	22678	0.0023
expansion-0002_0.tif	2	11.7988	11.7998	35756.6	0.0046
expansion-0003_0.tif	3	17.199	17.1993	49392.6	0.0070
expansion-0004_0.tif	4	23.0009	23	63458.8	0.0093
expansion-0005_0.tif	5	28.5019	28.5022	77877.6	0.0117

Figure 3.5: Analog data spreadsheet.

calibration process.

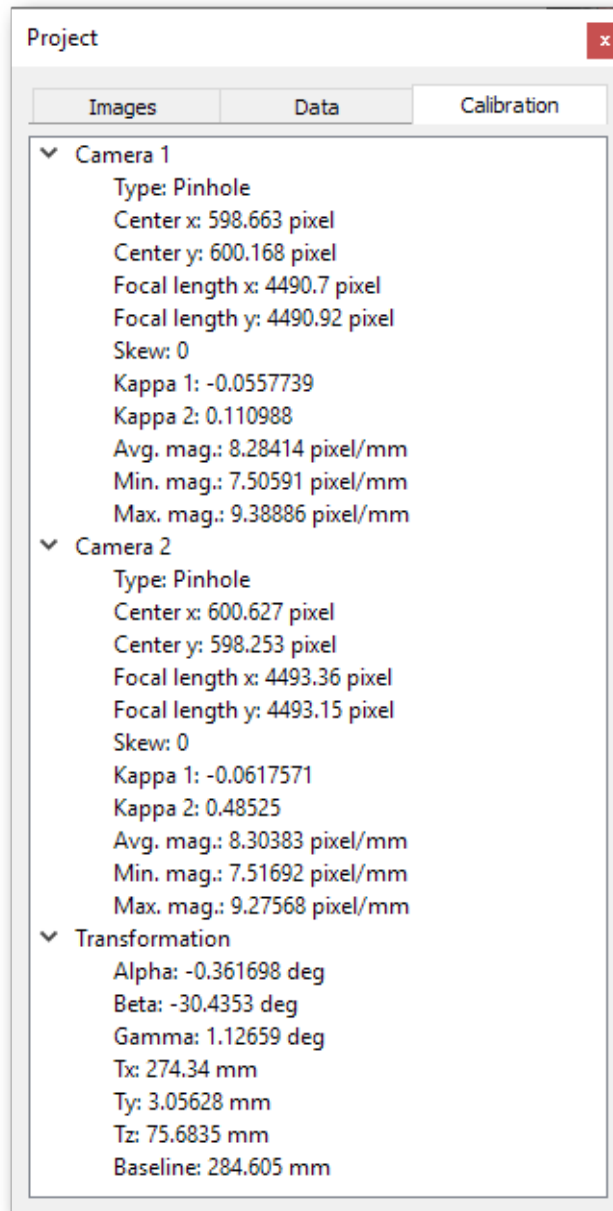

Figure 3.6: Project toolbar calibration tab.

Intrinsic camera parameters are displayed for each camera:

- sensor center
- focal length (in pixels)
- skew
- 1, 2, or 3 radial distortion coefficients, depending on selected order
- tangential and prismatic distortion coefficients, if enabled in the [imaging system](#)

- estimated magnification, for convenience

Extrinsic parameters are displayed for the stereo rig:

- rotation angles alpha, beta and gamma
- translation components T_x , T_y and T_z between the cameras
- baseline: distance between cameras (resultant of T_x , T_y , T_z)

i For a typical setup where the cameras are on a horizontal stereo bar, the angle beta corresponds to the stereo angle.

Chapter 4

Speckle and Calibration Images

In Vic-3D, images are the main input data used for calibration of the stereo system as well as displacement and strain analysis. There are two main categories of images

- speckle images
- calibration images

Both types of images can be displayed in the workspace by double-clicking on the name of the image in the *Project Toolbox* (see [Section 3.3](#)) after they have been added to the project.

4.1 Adding Speckle Images

In Vic-3D, speckle images are images taken of a specimen as it undergoes load or motion and are used to extract information about shape, displacement and strain using digital image correlation. One or more speckle images can be added to the project by selecting the *Speckle images* entry from the *Project* menu, or by clicking the  icon on the [main tool bar](#). The images can then be selected in a standard file dialog.

For adding larger groups of speckle images, it is preferable to select *Project... Speckle image groups* from the menu bar. The folder containing the image set can then be selected in a standard file dialog. After a directory has been selected the software categorizes the images contained in the folder into groups with consistent naming. One or more such groups can be selected for import into the project. (Due to operating system limitations, trying to add too many images directly through the normal *Speckle images* dialog may result in only a subset of the images being imported.)

After adding speckle images to the project, they will be displayed in the workspace and listed in the *Images* tab of the project bar as shown in [Fig. 4.6](#).

4.2 Adding Calibration Images

Calibration images can be added by selecting the *Calibration images* entry from the *Images* menu, or by clicking the  icon on the [main tool bar](#).

After adding calibration images to the project, they will be listed in the *Images* tab of the project bar, as illustrated below.

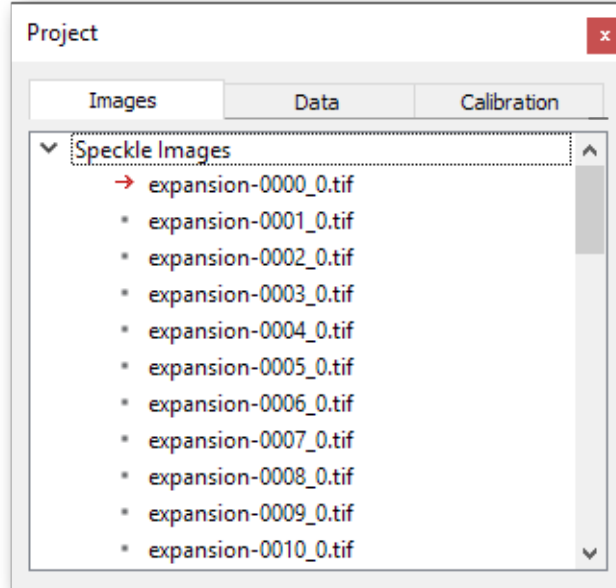

Figure 4.1: Project image panel showing speckle images.

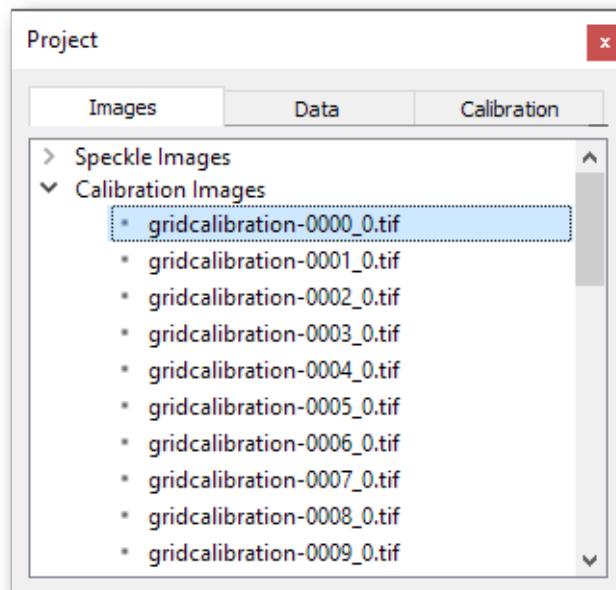

Figure 4.2: Calibration image list in project panel.

4.3 Working with Images

Once images have been added to the project, they can be viewed, animated or removed from the project. The following sections explain such common tasks which are almost identical for speckle and calibration images.

4.3.1 Image File Formats

The recommended image file format is uncompressed, monochrome **TIFF**. The following configurations of TIFF files are supported:

- 8-bit monochrome images.
- 16-bit monochrome images. The software automatically determines the actual bit-depth of the input image if the input has two bytes per pixel.
- 32-bit floating point images. Note that the `s_min` and `s_max` fields must be set to the correct range.
- 8-bit RGB(A) images (note that color images are converted to monochrome and are generally not recommended)

Vic-3D supports a number of other image file formats. Note that color images are not recommended if they are acquired with sensors that have color filters (Bayer filters), as the displacement resolution is typically strongly degraded. For similar reasons, lossy image compression algorithms should be avoided. Loss-less compression algorithm do not degrade the displacement data, but typically do not yield high compression ratios for speckle images. The following image formats are supported but should be used with caution:

- JPEG images
- Portable Network Graphics (PNG)
- Netpbm images
- BMP images

4.3.2 Viewing Images

Deformed images can be displayed in the workspace by double-clicking on an entry in the image list view. Alternatively, clicking the right mouse button on an entry of the list view will show a pop-up menu providing different options, one of which is *View*.

The image viewers in Vic-3D, including in contour plots, all provide a consistent user interface for zooming and panning using the mouse wheel and left-click/drag, respectively. The brightness and contrast can also be adjusted using the histogram in the toolbar. In addition, the zoom in/zoom out entries in the *Edit* menu or the corresponding tool buttons can be used to change the scale of the displayed image.

4.3.3 Animating Images

To animate speckle images, the controls on the *Animation Toolbar* (see [Section 2.11](#)) can be used. By default, the entire sequence of speckle images will be played when the animation is

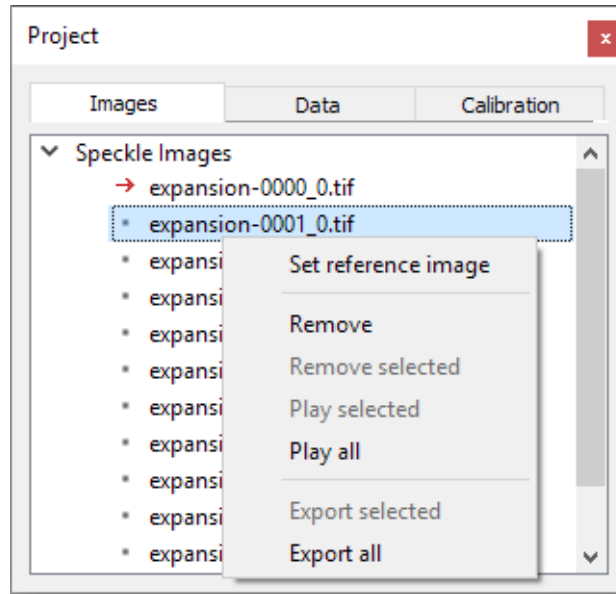

Figure 4.3: Image panel context menu.

started. It is also possible to animate only a subset of the image sequence, or the calibration images, by selecting a number of images from the list and then right-clicking. A pop-up menu will then appear and the entry *Play selected* can be used to play only the selected images.

4.3.4 Changing between Cameras

To change between the two cameras of the stereo-system, a right-click in the image viewer will display a pop-up menu as shown in the figure below. Using the *Toggle camera* button allows switching between the two stereo camera. Note that the title bar of the image viewer displays the current image file name that contains the camera ID.

4.3.5 Removing Images

Images can be removed by first selecting one or multiple images in the list view, and then either pressing the *Backspace* key or by right-clicking on the selection. The latter method will show a pop-up menu with an option to either remove only the image clicked on (*Remove*) or the entire selection (*Remove selected*) from the list.

4.4 The Reference Image

The term *Reference Image* is used in this manual to describe the image of the specimen where all displacements are zero. Typically, this image is taken while no load or a small amount of pre-load was applied. All displacement analyses in Vic-3D are with respect to this reference image, i.e., the displacements are obtained in a Lagrangian coordinate system.

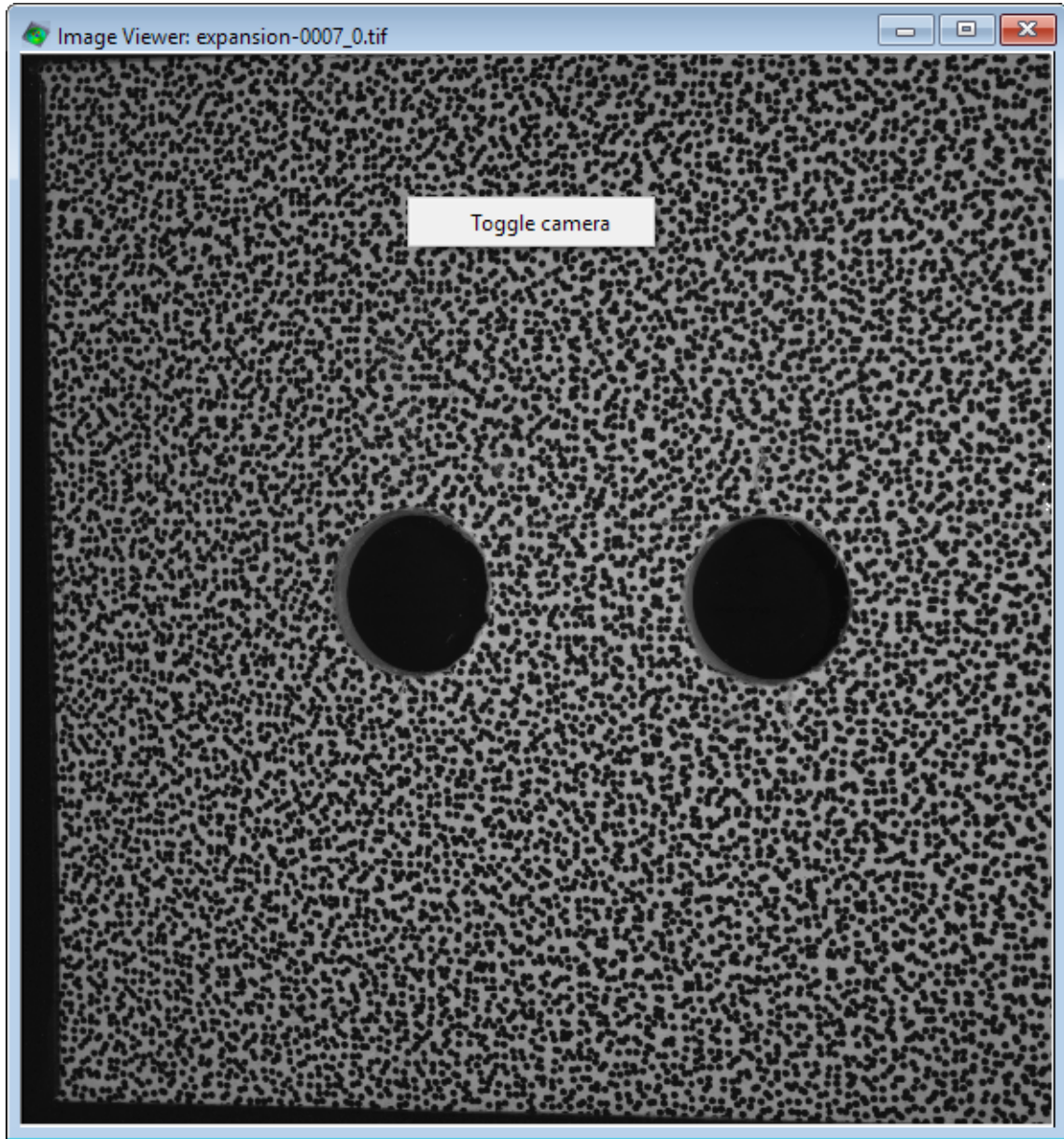

Figure 4.4: Right-button menu in image viewer.

When importing speckle images, Vic-3D automatically uses the first image as the reference image, which is indicated by a red arrow (see figure below). To select a reference image, right-click on it in the *Speckle images* list, and select *Set as reference*. from the pop-up menu as illustrated in Fig. 4.5. After the reference image has been selected, it will be indicated with a red arrow in the images list as illustrated in Fig. 4.6.

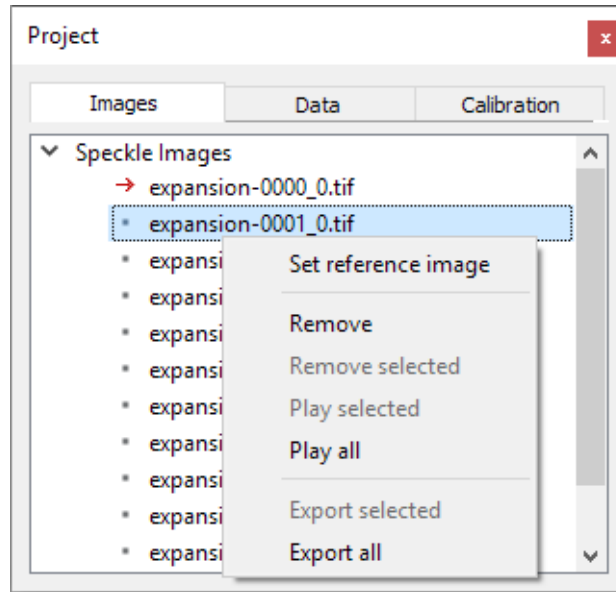

Figure 4.5: Speckle image list right-click menu.

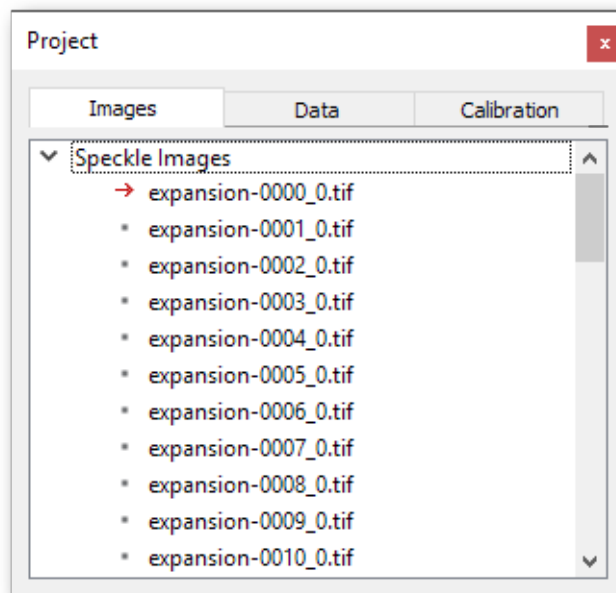

Figure 4.6: Reference image indicator

Note that changing the reference image after selecting an area-of-interest (see below) will clear the selected area-of-interest, as each reference image can have its own mask. In order to reuse an already defined area-of-interest for a different reference image, a right-click in the AOI editor provides the option to paste existing masks onto the new reference image. If the reference image is changed back to an image for which a mask had already been defined, the previously defined mask will be reused.

When the AOI editor has the focus in the workspace window, the mask tool buttons become active as shown in Fig. 4.7. The AOI editor can normally be activated by double-clicking on the reference image, unless the image viewer has focus in the workspace. In this case, the AOI editor can be activated by clicking on it or by selecting it from the *Window* menu.

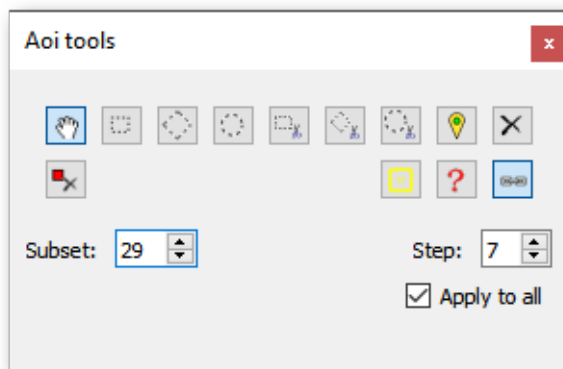



Figure 4.7: Aoi tool box.

4.4.1 Placing Start Points

In some situations, one or more start points may be needed for the correlation. Aside from providing a location from which to start the correlation process, start points are used to provide initial guesses for deformed images. The software attempts to find initial guesses for deformed images in a background thread, and it is therefore recommended to place a start point directly after selecting the reference image. After pressing the  icon, a start point can be added to the reference image by clicking on the desired location in the reference image. Detailed information about selecting end editing start points is provided in [Chapter 6](#), including general guide lines on what makes a suitable location for a start point.

To remove a start point, click the  icon, then click the start point. Alternatively, a start point can be removed by pressing either *Backspace* or *Delete* while the mouse hovers over the start point and the AOI editor is the active window in the workspace.

i To speed up displacement analysis later on, it is helpful to place a start point in a suitable location. Once a start point has been placed, Vic-3D computes initial guesses in a background process. When the mouse hovers over a start point, status information of the background analysis is displayed.

4.4.2 Selecting an Area-of-Interest

The area-of-interest defines the area of the image in which Vic-3D performs correlation analysis. Vic-3D supports the following types of AOIs:

- **Rectangle:** Points are contained in a rectangular area.
- **Polygon:** Points are contained in an arbitrary polygon.
- **Circle:** Automatically creates a roughly circular polygon.

To specify a particular type of AOI, select the corresponding entry in the *Edit* menu or the appropriate button on the tool bar. The selected AOI type will be indicated by the mouse cursor.

After selecting the AOI type, move the cursor to the desired position in the reference window and click the left mouse button. You can now move the mouse to the next position, e.g. the end of the line or the second corner of the rectangle. Clicking the left mouse button again will complete the AOI selection for all AOI types except polygons. For polygon selection, a double-click is used to specify the last point of the polygon.

i To pan the image while an editing tool is active, the **SHIFT** key can be used to temporarily disable the editing tool. During AOI editing operation, the image can be scrolled by moving the mouse outside the reference image window. This will cause the image to autoscroll if the image does not fit on the display.

4.4.3 Editing AOIs

To edit an existing AOI, select the Pan/Select tool. Mouse over any of the white nodes in your AOI; the mouse cursor changes to indicate node movement. Click and drag to move. You can delete a node by clicking the  icon, then clicking the desired node.

If the merge polygons icon () is selected, any overlapping polygons will be merged with each other. If the icon is not selected, overlapping AOIs will remain separate.

Areas-of-interest can be translated by clicking anywhere inside the area and then translating the AOI before releasing the mouse button. To pan the image instead of moving the AOI, the **SHIFT** key can be pressed while clicking on the AOI.

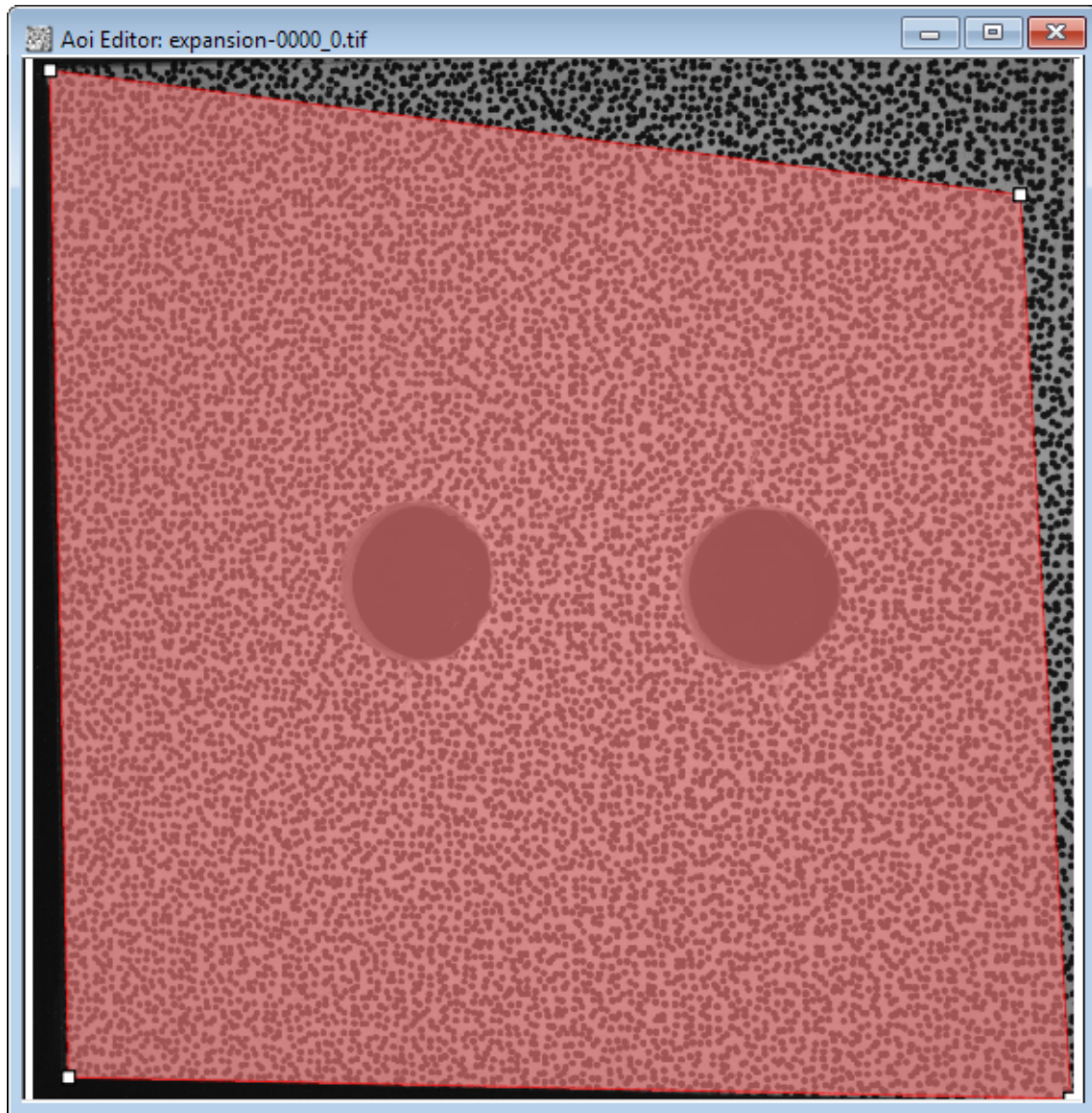

Figure 4.8: Selecting an area-of-interest.

4.4.4 Cutouts

For rectangular and polygon AOIs, the scissors tool can be used to cut areas from the AOI. This feature is most commonly used if the specimen has cracks, holes, or other areas where correlation is impossible.

To cut an area from an AOI, click the scissors button on the tool bar or select *Edit... Cut region*. The selection of the area to be cut works like selecting a polygon AOI, i.e., corner points of a polygon can be added by single-clicking the left mouse button, and the last point is specified by a double-click. Once the cut is complete, new nodes are added to your AOI; these may be moved like other nodes.

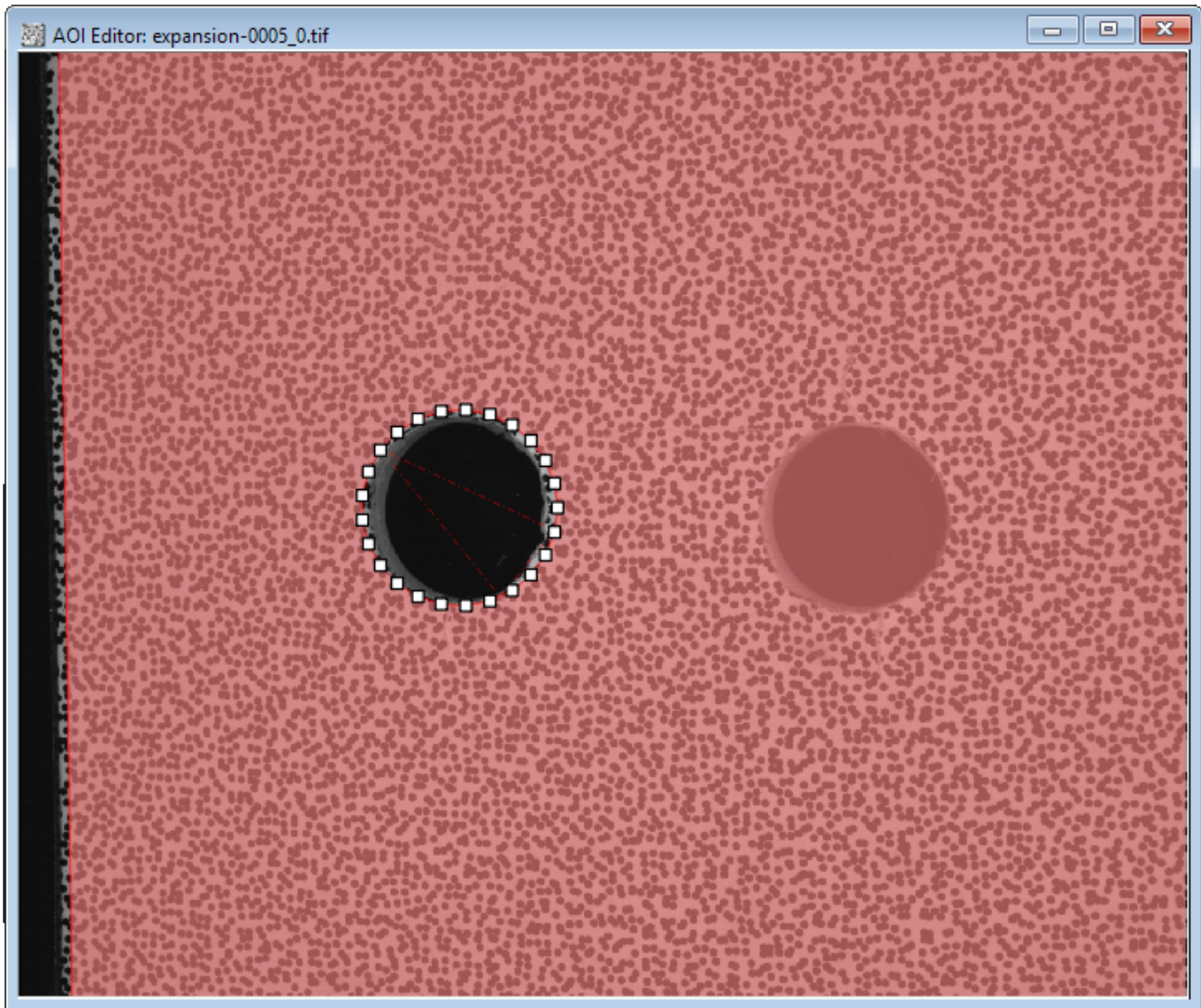

Figure 4.9: Cutting out of an AOI.

i When using multiple AOIs for one image, click on an AOI with the pan/select tool to activate it. The active AOI is indicated by the control points, which are hidden for inactive AOIs. Cuts will only be applied to the active AOI.

4.4.5 Choosing the Subset and Step Size

The subset and step size can be selected after an area of interest is created. Both are adjusted using the spin boxes in the AOI Toolbar.

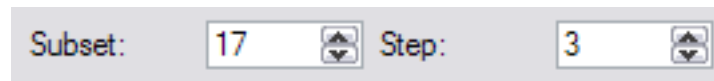

Figure 4.10: Subset and step size control.

The subset size controls the area of the image that is used to track the displacement between images. The subset size has to be large enough to ensure that there is a sufficiently distinctive pattern contained in the area used for correlation. If you change the subset size, you will see the current size illustrated by a grid briefly displayed on the AOI. To have Vic-3D suggest a subset size, click the **?** icon:

Vic-3D will choose a subset size which is calculated to give an optimal match confidence of 0.01 pixel for a given assumed noise level. The default of 8 works well for most cameras. To accept the suggested size, click **Ok**; to return without making a change, click **Cancel**.

The step size controls the spacing of the points that are analyzed during correlation. If a step size of 1 is chosen, a correlation analysis is performed at every pixel inside the area-of-interest. A step size of 2 means that a correlation will be carried out at every other pixel in both the horizontal and vertical direction, etc. Note that analysis time varies inversely with the square of the step size; i.e., a step size of 1 takes 25 times longer to analyze than a step size of 5.

To cause subset and step size changes to apply to every AOI, check the *Apply to all* box. If this box is cleared, subsets and steps can vary between AOIs.

i All operation on AOIs can be reverted using the Undo/Redo buttons. The Undo/Redo buttons in the *Edit* menu will indicate what changes can be undone/redone.

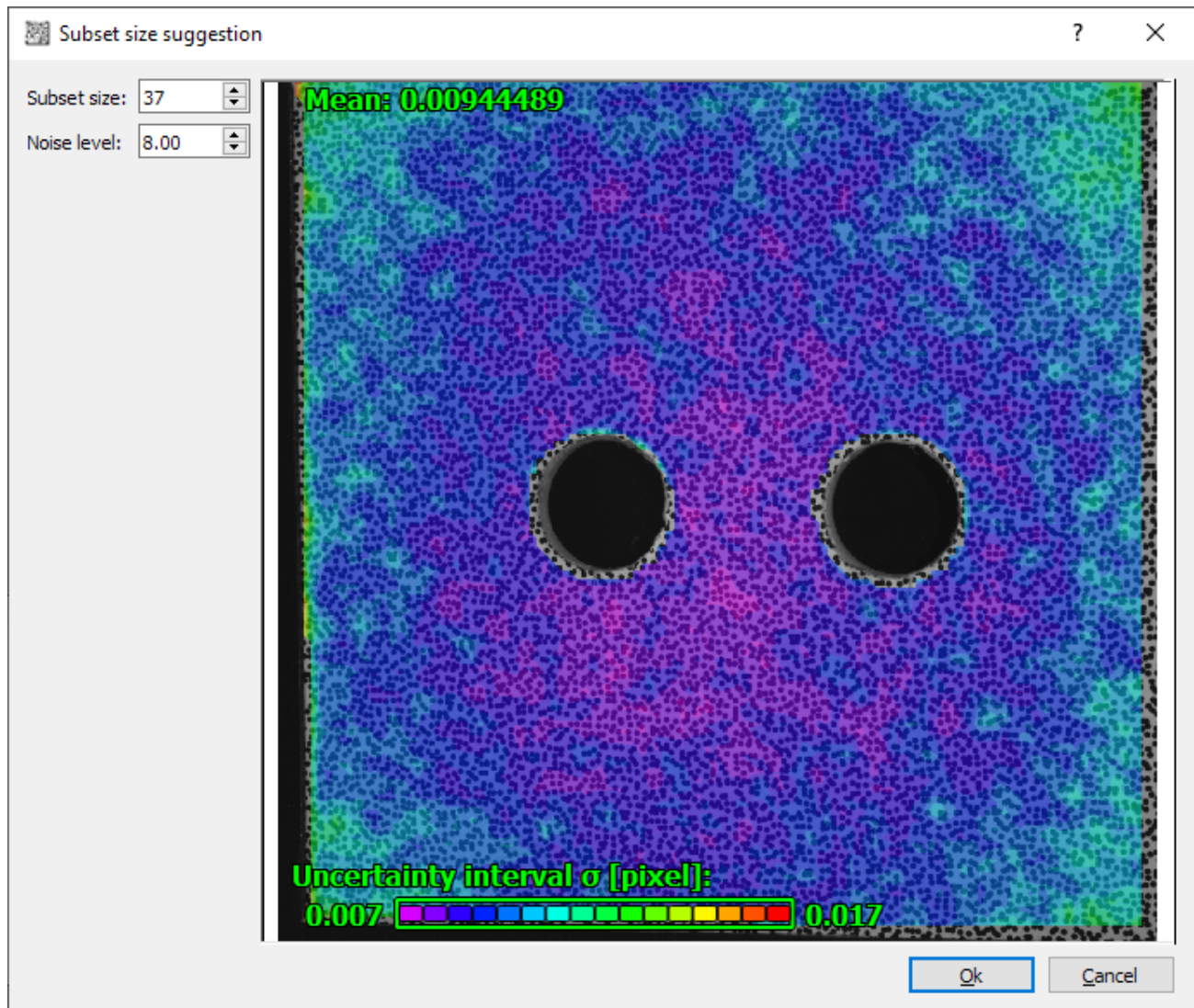

Figure 4.11: Subset size suggestion dialog.

Chapter 5

Calibration

Calibration can be accomplished either through a stereo calibration where intrinsic and extrinsic parameters are calculated together, or a separate calibration where the intrinsic parameters are determined for each camera separately and the relative orientation of the cameras is determined from a common view.

For most applications, [stereo calibration](#) is used. The calibration target is imaged simultaneously in both cameras, and the synchronized target images are used to fully calibrate the system in one step.

In certain applications, a stereo calibration with a conventional full-size target is not practical, e.g., when the field of view is very large. In such cases a [separate calibration](#) method can be used.

In this method, each camera acquires target images separately. These images are used to calculate intrinsic parameters for the cameras. A static speckle image is then used to establish the camera orientation. For this method, the speckle image must contain markers or fiducial points with a known distance between them.

Cases where separate calibration will be useful include:

- Very large fields of view
- Cameras that cannot be synchronized
- Cameras that must be moved after calibration
- Certain complex mirror setups

5.1 Stereo Calibration

To begin, select the *Calibrate stereo system* entry from the *Calibration* menu, or click on the  icon on the tool bar. The calibration dialog will appear:

For new, coded grids, the grid parameters will be determined and the grid points will be automatically extracted. If the grid cannot be recognized or is uncoded, select the grid from the **Grid** pulldown and click **Analyze** to extract points.

A number is displayed for each image - this is the total number of points extracted (0 for failed images). The computed dot positions are displayed during the extraction; the three hollow orientation dots are labeled with different colors, and the coding dots, if present, are labeled in red.

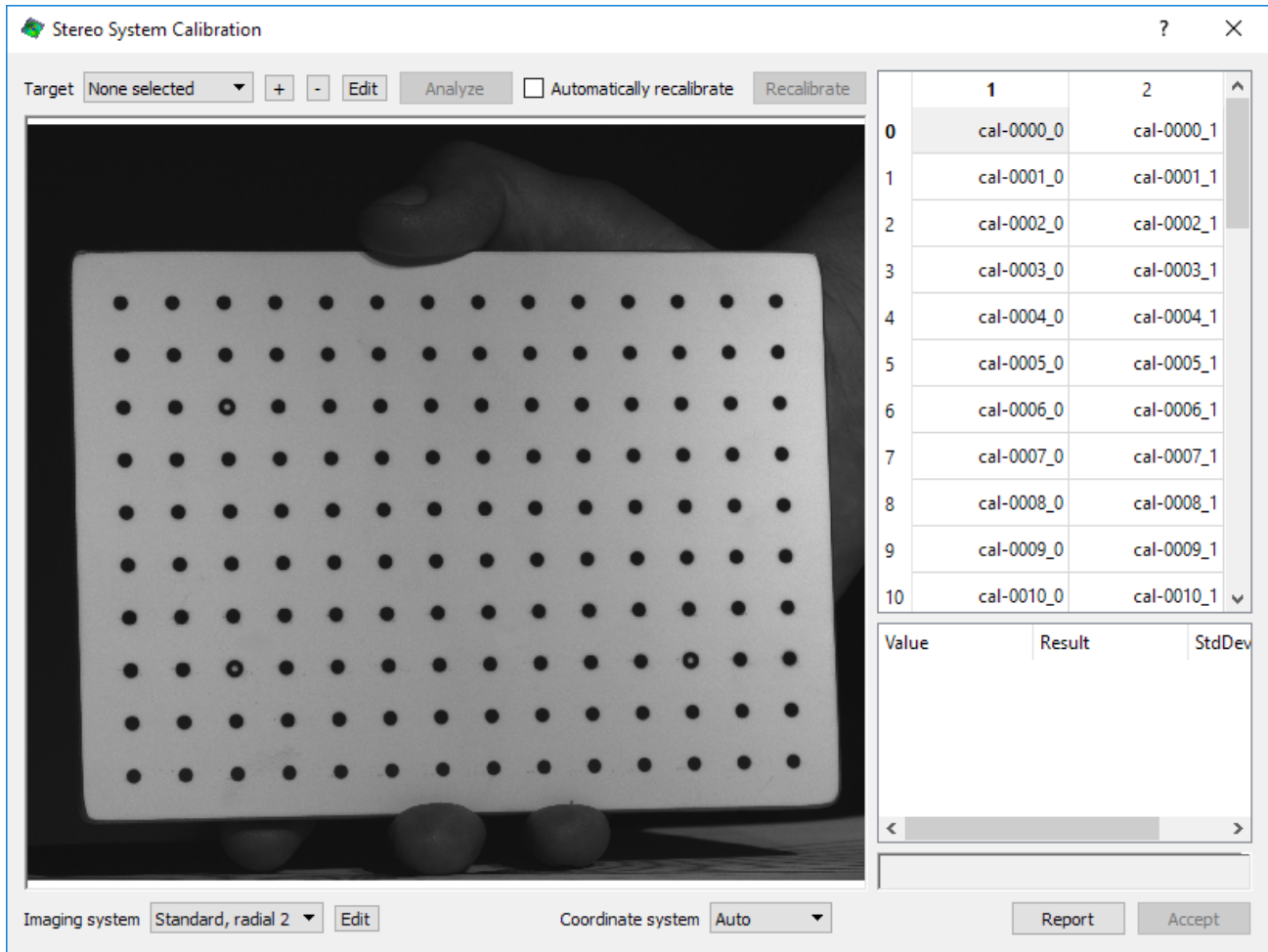

Figure 5.1: Calibration dialog.

Once image analysis is complete, the calibration will be computed. If the score is higher than optimal, any outlying images will be discarded and the calibration computed again. The final score (in pixels, lower is better) is displayed in the bottom right.

Click **Accept** to use this calibration.

5.1.1 Coordinate system selection

If this control is left at *Auto*, the resulting coordinate system will be centered about the camera pair.

If a grid orientation is selected from the pulldown, this orientation will become the center of a new Cartesian coordinate system. If we consider the three hollow dots as an “L”, the corner dot of the L will become the origin; the horizontal leg of the L will be the positive X axis; and the plane of the grid will be the XY plane.

The selected coordinate system is not reflected in the displayed calibration parameters, which only show the *relative* position of the two cameras; however, the necessary information regarding the *absolute* position is stored in the project file.

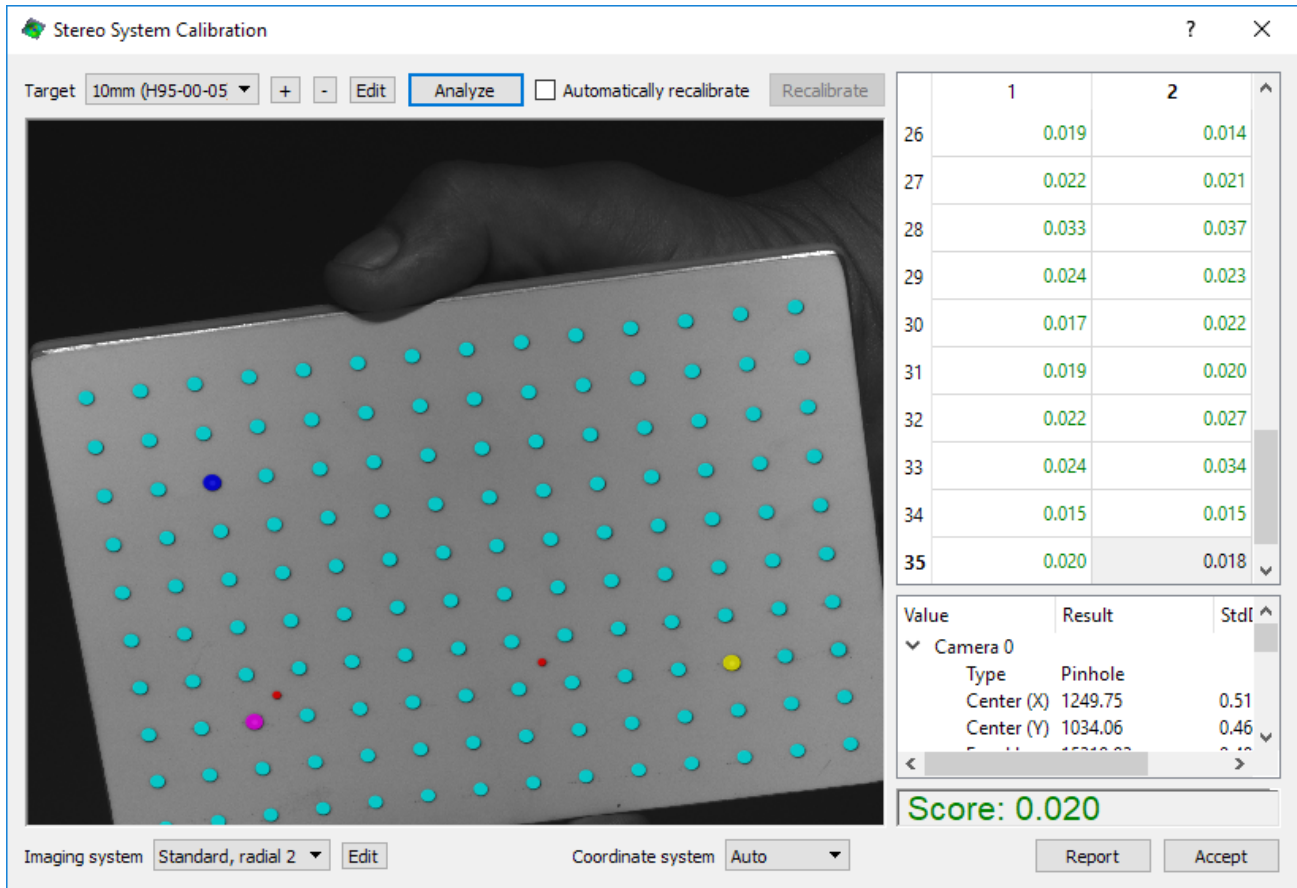

Figure 5.3: Calibration results.

5.1.3 Results in Detail

For each image, a score is displayed. This is the average error (in pixels) between the position where a target point was found in the image, and the theoretical position where the mathematical calibration model places the point. Good scores will be displayed in green; higher scores will be red. To remove a certain image from the calibration, you can right-click on it and select **Remove Points**. To use points from an image which has been cleared, right-click again and select **Extract**.

Calculated calibration values are displayed in the tree view to the lower right. Each item has a value as well as a +/- confidence interval (one standard deviation).

To view a report containing all the information as text, click **Report**. This report can also be copied to the clipboard and saved for later reference.

5.1.4 Recalibrating

Vic-3D will attempt to remove any outliers while leaving good images present. However, it will sometimes be necessary to manually remove images, or return automatically removed images.

To remove an image pair, right-click in the results table and click **Remove row**. You may also select multiple rows at one time. If the **Automatically recalibrate** box is checked, the

calibration will be immediately recomputed. Otherwise, click **Recalibrate** when necessary.

To return a removed image pair to the calculation, right-click in the table and click **Extract row**, or select multiple rows and right click.

To use a certain grid orientation as the XY plane for the results coordinate system, select the relevant image from the **Coordinate system** pulldown. Use the *Auto* selection for a coordinate system centered about the camera rig.

5.1.5 Calibration Target Selection

If the grid used is not listed in the pulldown, click + to add a new one or **Edit** to edit the current settings. When clicking +, Vic-3D will attempt to automatically extract the grid information, and will fill it in if found; in this case, only the grid spacing must be entered.

To remove a previously entered grid, select it and click the - icon.

The diagram below illustrates the meaning of each grid parameter:

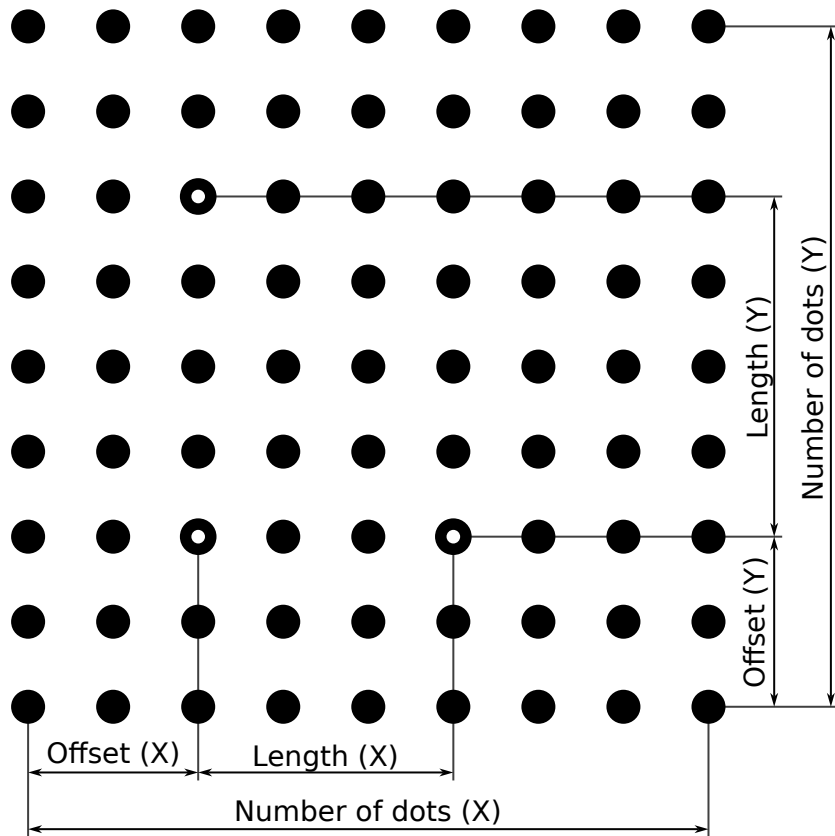

Figure 5.4: Calibration target definition.

5.1.6 Imaging Systems

To specify the imaging system used, use the **Imaging System** pulldown at the bottom left.

The imaging system comprises the sensor, the imaging lens, and any fluids or interfaces present (windows, environmental chambers, etc.) Imaging systems can be added and edited by clicking on the **Edit** button in the lower left-hand corner of the calibration dialog. The imaging system dialog is shown in Fig. 5.5.

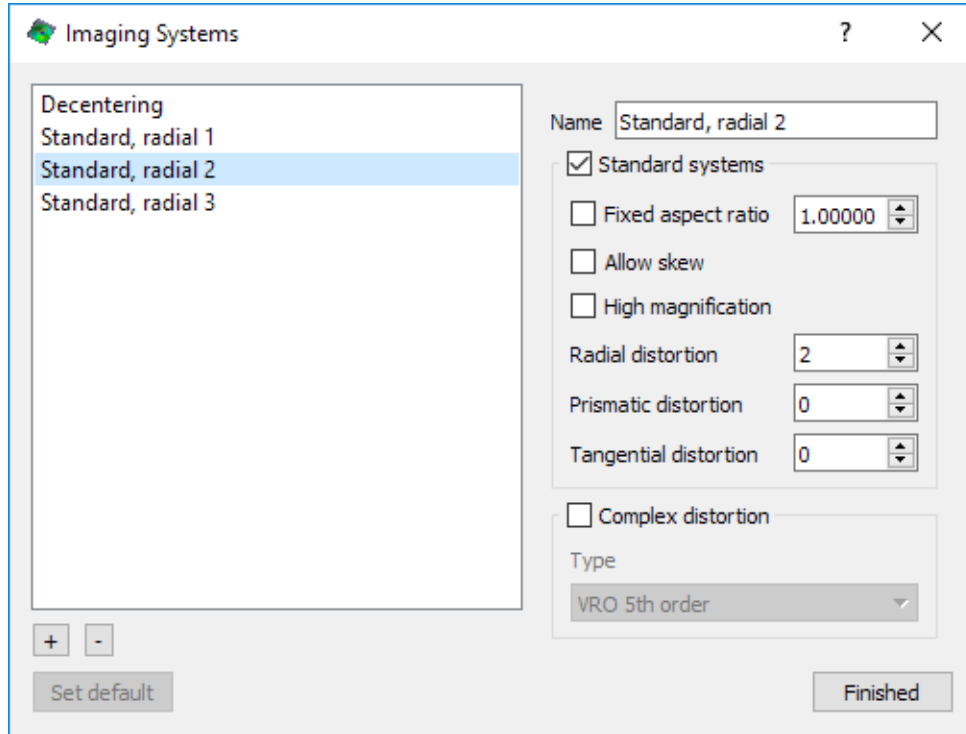

Figure 5.5: Imaging system dialog.

You can add or remove a system by clicking the + or - buttons. The following parameters may be set for each system:

- Name: this is a friendly name for the system; for example, “Schneider 17mm” or “Underwater test”.
- Standard systems: select this for a typical imaging lens in free air.
 - Fixed aspect ratio: check to enforce a fixed aspect ratio when it is known for the camera.
 - Allow skew: if the camera is known to have zero skew, you can clear this box.
 - High magnification: check to force the Center parameters to the geometric center of the lens. This replaces the “High magnification” checkbox in the previous calibration dialog.
 - Radial distortion: this is the order of the radial component of the Seidel distortion. Choose the appropriate order for your lens.
 - Prismatic distortion: this is the order of the thin prism component of the Seidel distortion.
 - Tangential distortion: this is the order of the tangential, or decentering, component of the Seidel distortion.

- Complex distortion: select this when optical interfaces are present. This introduces a Variable Ray Origin calculation which allows correction for varying refraction across the sensor surface.
 - Type: Typically, the 4th order VRO model is sufficient. A 5th order model is provided for extreme conditions. For these types of use cases, it is recommended to pay particular attention to the calibration image sequence and ensure that a grid of proper size is used and sufficiently large tilt angles of the target are recorded during calibration.

Click **Finished** when done.

To make an imaging system the default, click **Set default**.

5.2 Hybrid Calibration

The hybrid calibration dialog uses both calibration grid and speckle correlation data to improve calibration results through bundle adjustment. This method has a number of advantages compared to traditional calibration methods using fiducial points only.

- A noise estimate for the input data is available for the speckle correlation results. By comparing this noise estimate to the calibration residual, residual bias in the calibration becomes obvious.
- The noise on speckle correlation data is typically lower than the noise on ellipse centers resulting in more reliable calibration.
- A large number of data points can be generated using speckle correlation.
- Meaningful error metrics, e.g., bias in strain or rigid motion, provide intuitive information about calibration quality (for some of the hybrid methods, see below).
- The distribution of projection errors reveals incorrectly calibrated distortions.
- The spatial distribution of noise sensitivity in all three axis directions can reveal problems with the stereo camera configuration.

In order to complete a hybrid calibration, the system must first be calibrated as normal using a calibration grid. Based on this calibration, a set of speckle images is then analyzed to generate the additional calibration data for hybrid calibration. Note that the [imaging system](#) selected in the stereo calibration is the one that will be used for hybrid calibration. Once the data has been generated, the hybrid calibration dialog can be launched from the menu bar by selecting **Calibration... Hybrid stereo system calibration**. This will show the following dialog:

5.2.1 Hybrid Methods

There are three different methods for hybrid calibration available that can be selected from **Method** combo box:

- **Rigid speckle and scale from grid**: This method requires a set of images of a **rigid** calibration object undergoing **tilt and out-of-plane motion**. For this method, the

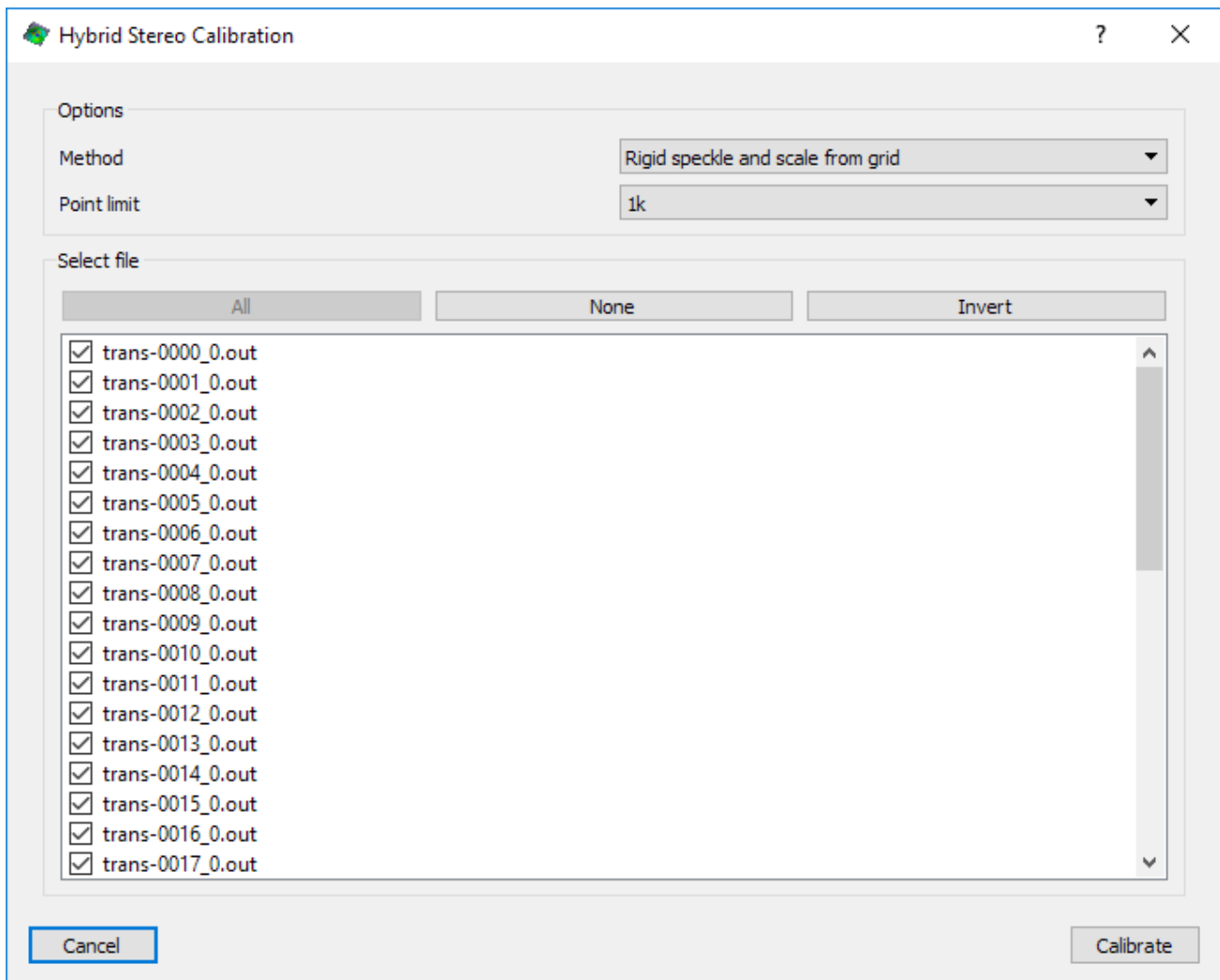

Figure 5.6: Hybrid calibration dialog.

speckle image sequence should be taken like a calibration sequence with a dot grid target. The only thing that is retained from the grid calibration is the scaling (along with the imaging system selection). With a proper calibration sequence, this method will give the best results because only speckle correlation data is used to determine the calibration parameters (aside from scaling).

- **Grid points and rigid speckle:** this method requires a set of images of a **rigid** object undergoing motion. The data points from the grid images are combined with points from the 3D correlation results. This method should be used if the speckled object is known to be rigid, but the motions of the object are insufficient for complete calibration. For instance, if only a few small translations and/or tilts of the object are available, this method can provide improved results versus using only the calibration dots from the traditional calibration target.
- **Grid points and deforming speckle:** this method will work with **any image set**, including images of the (deforming) test article itself. In essence, this method computes an

optimal triangulation for the calibration points and point correspondences found by DIC for an entire dataset together.

Note that for all calibration methods, it is generally required to have a calibration object that fills the entire field of view. Additionally, for the hybrid methods it is required that the stereo configuration remains the same between the acquisition of dot calibration target and speckle images.

5.2.2 Point Limit

The number of calibration points used for hybrid calibration is limited by selecting a **point limit** from the combo box. For the first two methods, where the calibration object is rigid, this point limit is equivalent to the number of calibration dots on a traditional target. Note that increasing the number of calibration points may provide limited returns at some point, as the input points are no longer independent due to subset overlap. For instance, an image with 2,000 pixels in both axes will only provide approximately 4,000 independent data points with a subset size of 31 pixels. Selecting a higher point limit will not provide additional benefits.

For the first two hybrid calibration methods that use a rigidity constraint, each calibration point is used in all views (images) it is present. Each image adds an additional view of the same rigid object, but no additional calibration points. This is different for the third method where no rigidity constraint is available. In this case, no two views of the same rigid object exist, i.e., each additional image adds additional calibration points, but no additional views. The point limit is therefore different for this method and will limit the total number of points collected from all images in the sequence. For this method, it is reasonable to use the maximum point limit available. Furthermore, it is recommended to limit the number of input data sets for this method (see file selection below). For instance, if a sequence of 4,000 images is used, only 16 points would be selected from each image even at a point limit of 64k. In such cases, it is best to manually deselect input files, as the point limiting algorithms does not decimate in time.

5.2.3 File Selection

The input files used for hybrid calibration can be selected from the file list. Note that a right-click in the list will pop-up a dialog with convenient options to select a subset of the input files, e.g., every other, one out of five or every N-th. This is particularly useful in cases where the input data is from a large sequence of a deforming object.

5.2.4 Calibration and Report

After pressing the **Calibrate** button, a text window will be displayed to report information about the progress and results of the calibration. Note that the calibration can take some time to complete, particularly when a large number of points is used in combination with complex camera models (prismatic and decentering distortions or non-pinhole models).

When the calibration is complete, the calibration results and confidence margins are displayed.

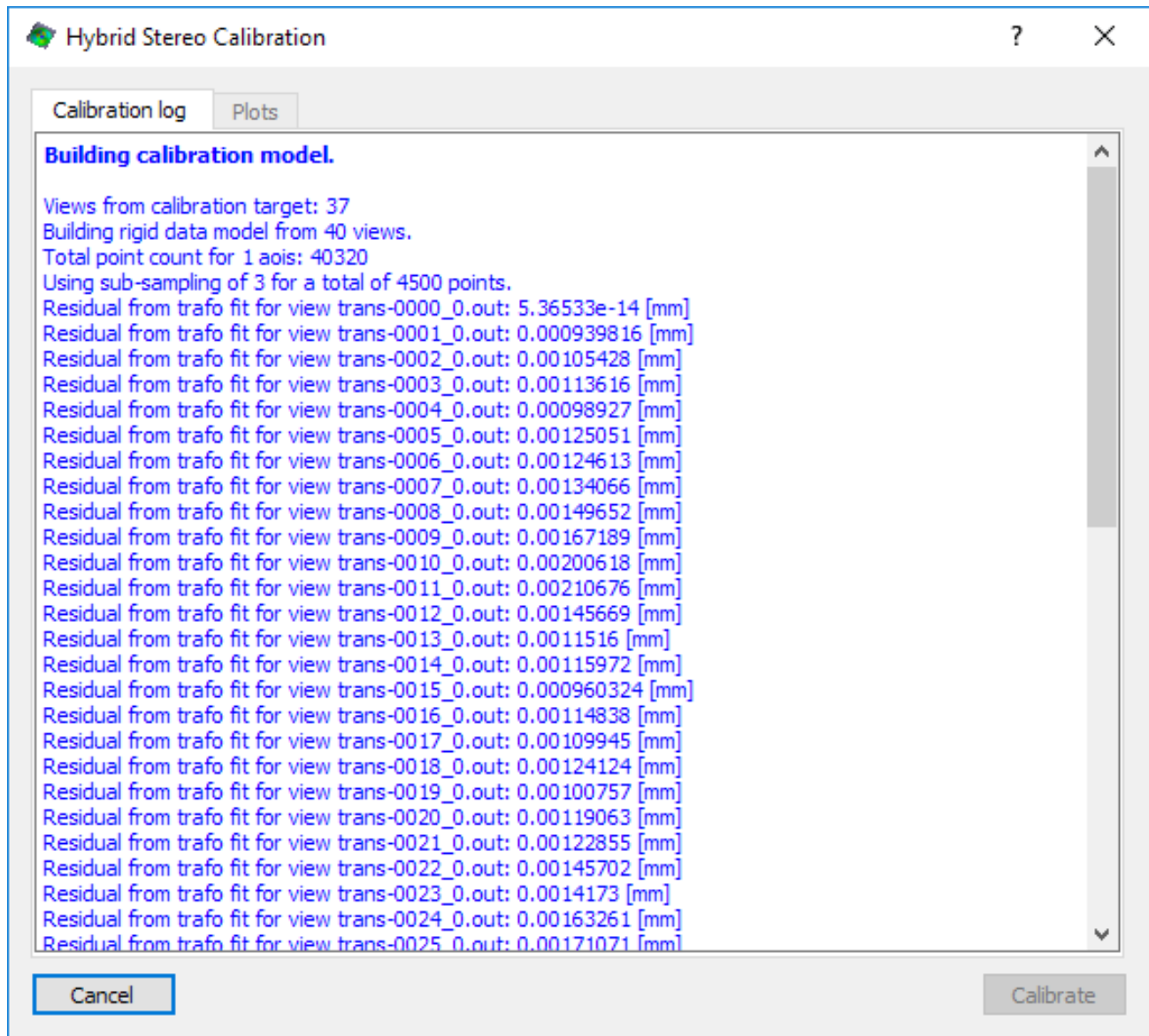

Figure 5.7: Hybrid calibration log.

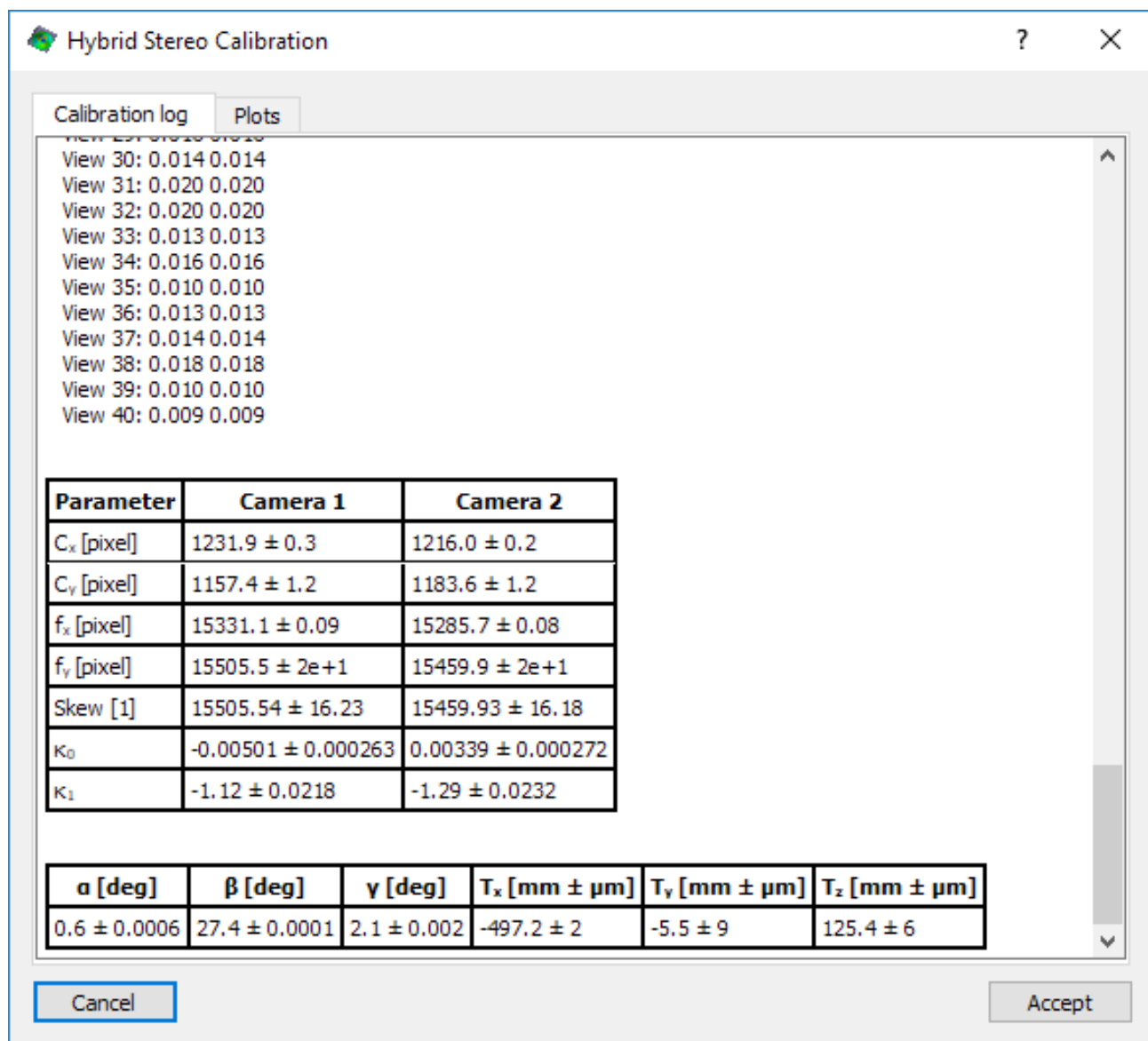

Figure 5.8: Hybrid calibration results.

5.2.5 Visualization of Calibration Errors

The **Plots** tab can be used to display a variety of plots that can provide detailed insight into the quality of the calibration, particularly for the hybrid methods that use a rigid object. When a data file is selected, a message bar in the bottom of the dialog shows the projection error and the noise estimate from correlation. For the first two methods (rigid object), additional information about average strains and residuals from a rigid body transformation fit are also displayed. This information is helpful in determining problems with the calibration.

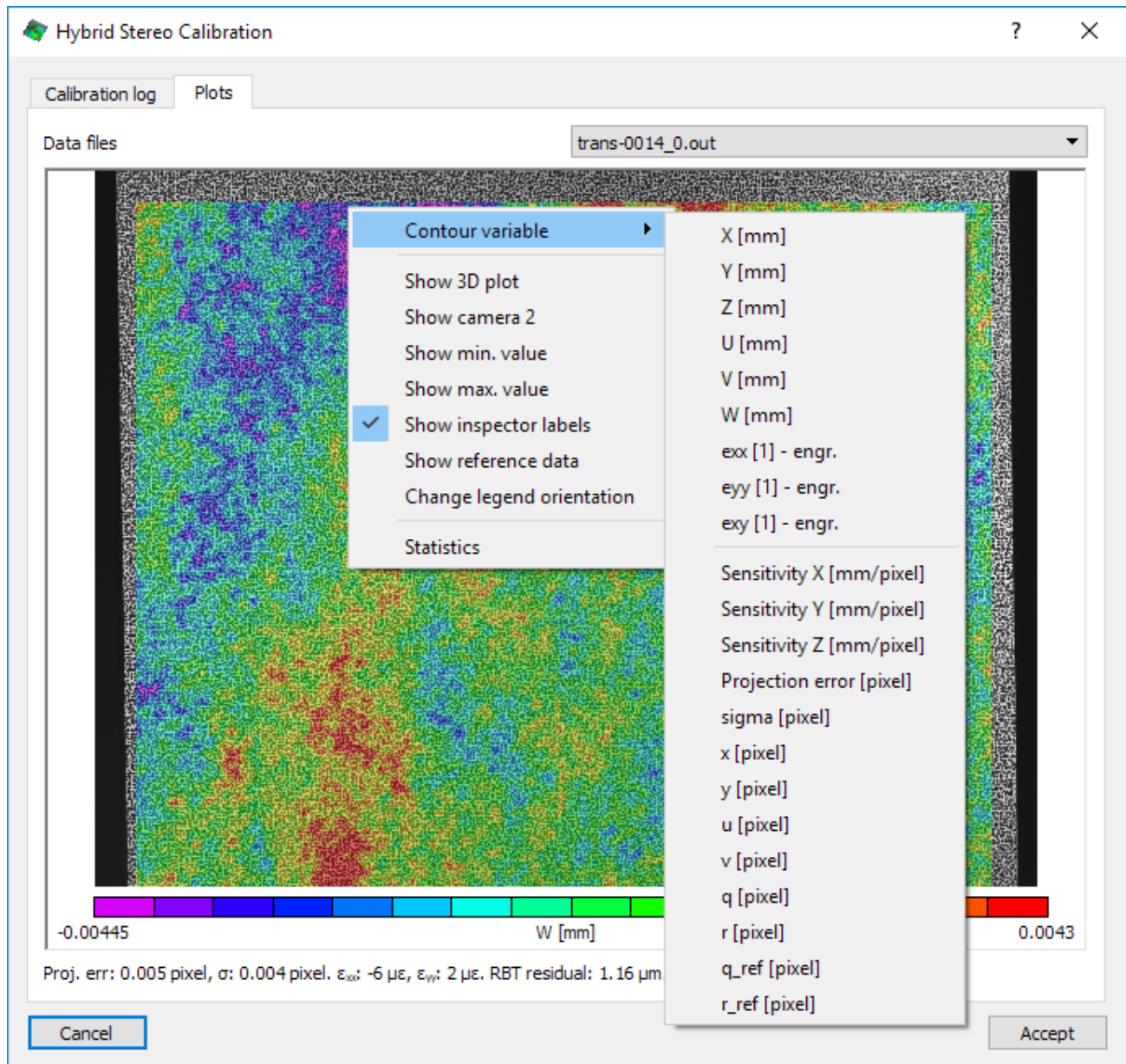

Figure 5.9: Hybrid calibration result plot.

Noise and Projection Error: The average noise estimate and projection error displayed near the bottom of the dialog should be similar in magnitude, and the distribution of the

projection error should be random throughout the entire image. If this is not the case, it normally indicates a problem with the calibration. There are a number of reasons why the projection error might be significantly higher than the noise estimate:

- The camera model cannot accurately capture the distortions. This normally results in a distinctive pattern in the spatial distribution of the projection error that remains similar for all data sets. It may be possible to correct such errors by selecting higher order or different types of distortions in the imaging systems dialog during the initial calibration.
- Heat waves often do not affect the noise estimate significantly but produce enough apparent displacement to increase the projection error. The spatial distribution of the projection error typically shows bands of increased error that vary from data set to data set. This problem should be addressed during image acquisition.
- If the object used for calibration is assumed to be rigid but deforms during calibration, a bias will result. This is difficult to distinguish from the following two cases. Repeating the calibration using the third method may provide further insight into whether the object is deforming or not.
- If the orientation of the cameras relative to each other changes during calibration, e.g., due to vibration, the projection error may increase.
- Synchronization problems have similar symptoms as the previous two error sources. Assuming that the calibration images of the dot target are similarly affected by this error as the speckle images, synchronization issues can be revealed by comparing errors from single camera calibration to the errors from stereo calibration. Such errors are normally flagged by the regular stereo calibration dialog.
- In situations where the errors are very low, e.g., 0.001 pixels, one of the errors may be two or three times higher than the other, and this often changes from image to image.
- Objects with significant curvature, surface discontinuities, defocus as well as very high tilt angles can also produce similar symptoms, but this is normally obvious when looking at the plots.

Displacement and Strain Distribution: The displacements (U, V and W) are shown with rigid body motion removed. Since the calibration object is rigid for the first two calibration methods, the resulting distributions should be random. Any distinctive patterns in the distributions of (residual) displacement or strain point to problems with the calibration.

Sensitivity: The (noise) sensitivity indicates how noise in the image matches impacts the measurement results. The sensitivity for the Z-direction is typically three to five times higher than for the inplane directions, depending on the stereo angle. The noise sensitivity is typically lowest in the center of the image and increases towards the boundaries.



If the noise sensitivity is significantly higher at the boundary than near the image center, the stereo angle and/or focal length may be too low. This can result in excessive noise in all measurements.

5.3 Separate Calibration

In some cases, it may be necessary or advantageous to calibrate the cameras separately for their intrinsic parameters followed by calibrating the system's extrinsic parameters. With this method, the cameras are calibrated using a target, and the geometry of the two cameras is determined from a speckle pattern – either a speckle target, or the specimen itself. This method requires that two marker points with a known distance on the specimen surface are present in the images.

5.3.1 Calibrating the Intrinsic Parameters

To calibrate the camera parameters separately, begin by adding calibration images to the project. **Note:** Vic-3D expects image files for both cameras to be present on the disk, even if only one of the two images is used.

Select *Calibrate... Calibrate Camera 1* from the main menu bar. Proceed through the [Calibration Dialog](#) as with stereo calibration; repeat for camera 2.

At this point, each camera is calibrated but the stereo rig transformation is still undetermined; this can be confirmed by viewing the Calibration tab of the project toolbar, as below.

5.3.2 Generating Disparity Data

To calibrate the camera orientation, add a reference image to the project and select an area of interest (AOI). Ideally, the AOI should cover as large an area of the image as possible.

Since the system is not calibrated, it may be required to provide an [initial guess](#) before starting the correlation analysis. When the system is only partially calibrated, Vic-3D displays the following message box when the analysis is started:

Click Yes to continue or No to cancel. Continuing will run a disparity analysis, where the raw image disparities are calculated but triangulation is not attempted, and no 3D shape will be calculated.

5.3.3 Calibrating the Orientation

After the disparity data has been calculated, the dialog for calibrating the camera orientation can be selected *Calibrate camera orientation* from the *Calibration* menu. The dialog shown below will appear.

On the displayed image, click and drag select a line between two marker points that are a known distance apart. After selecting the line, the following dialog will appear:

Enter the distance between the two marker points and click *Ok*. You can click *Calculate* to finish the calibration, or change the selected line. On completion, a calibration score will be displayed:

High numbers indicate problems with the underlying data; if necessary, adjust AOI or initial guess and re-run.

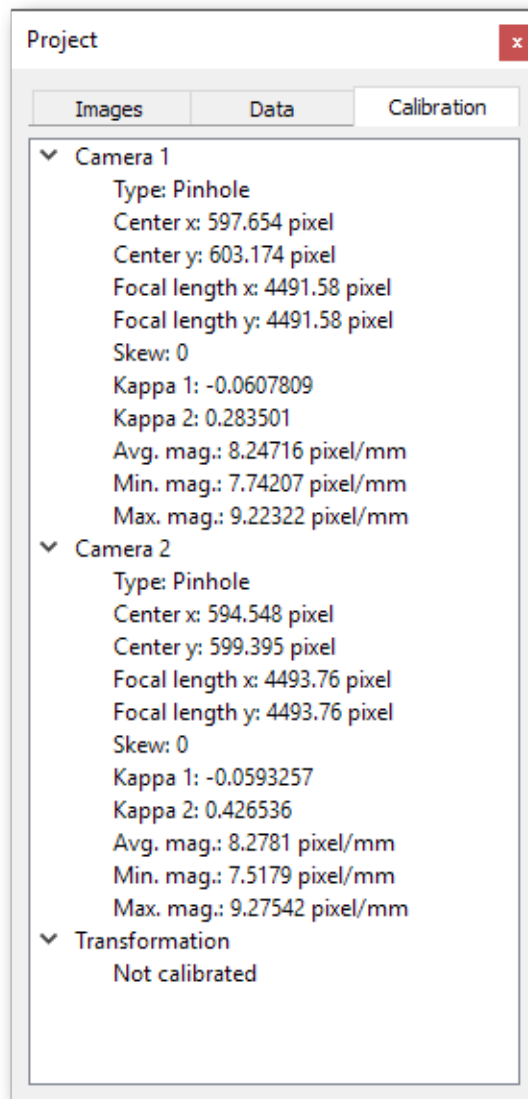

Figure 5.10: Project calibration showing missing transformation.

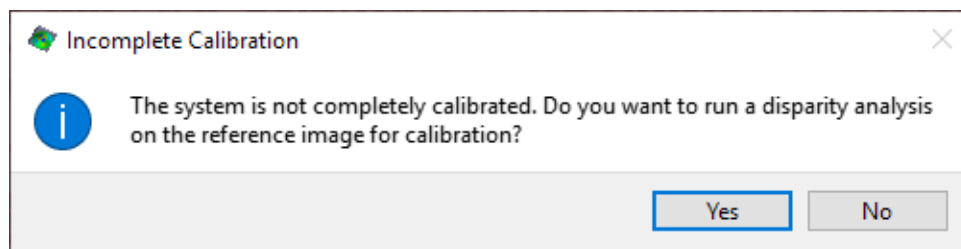

Figure 5.11: Disparity analysis message box.

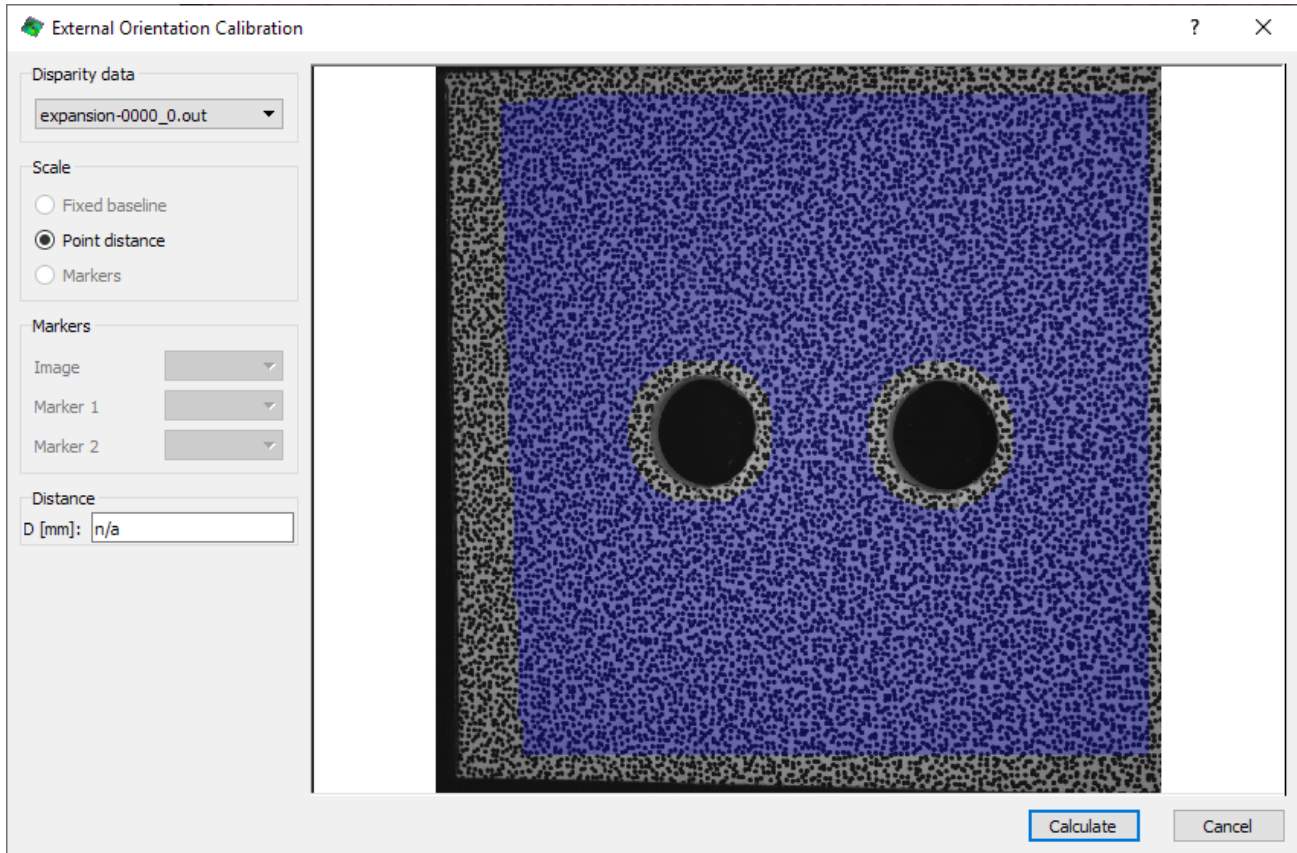

Figure 5.12: Orientation calibration dialog.

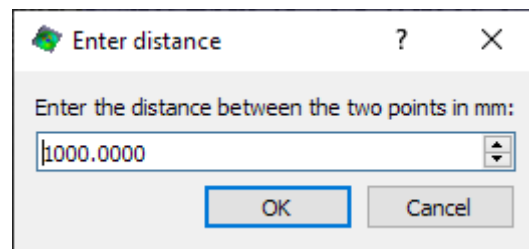

Figure 5.13: Setting the scale for orientation calibration.

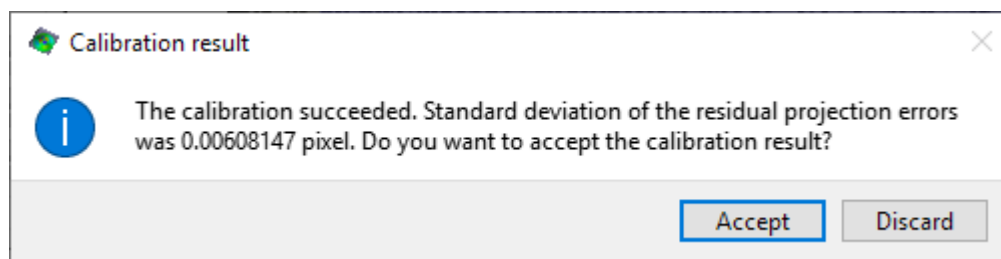

Figure 5.14: Orientation calibration results.

5.3.4 Correcting Camera Orientation in Pre-Calibrated Systems

The camera orientation calibration can also be used when the system has been calibrated using regular [stereo calibration](#). This can be useful in situations where the relative orientation of the two cameras was altered between the acquisition of calibration and stereo images, resulting in high projection errors. There are three options for setting the scale of the corrected calibration:

- *Fixed baseline*: This option assumes that the distance between the cameras has not changed (very much).

Note: the **autocorrect** feature (selected from the calibration menu) utilizes the fixed baseline method in conjunction with the disparity data from the reference file by default.

- *Point distance*: A line between two points can be drawn in the shaded area of the image. The software will determine the distance between the two end points from the data, but it can be manually overwritten if the distance is known.
- *Markers*: If markers with a known distance are available, they can be extracted in the *Marker Editor* and used to set the scale.

To perform this operation, select *Calibrate... Calibrate camera orientation*. Select the *Fixed Baseline* scale option, and click the *Calculate* button. A calibration score will be displayed; to proceed, click *Accept*.



Correcting the camera orientation in this manner should generally be avoided, particularly for setups with a low stereo angle and/or high magnification. If possible, it is recommended to acquire a speckle image pair after calibration and analyze it before proceeding with the experiment to ensure the projection errors are at acceptable levels.

5.4 Calibrating an External Camera



It is required to set a corresponding coordinate system both here and in the stereo system calibration dialog. If this step is skipped, mapping external data will not work correctly. See below for details.

In addition to the camera calibration for DIC, Vic-3D can also calibrate an external imaging camera to the DIC coordinate system. This is useful for mapping data from, e.g., an infrared camera.

- To calibrate an external camera, there must be a sequence of calibration target images for that camera; at least **one** of those images must show the grid in the same position as **one** of the stereo calibration images. If the external camera cannot be synchronized to the stereo system, it may be required to firmly mount the calibration target in a fixed position for at least one set of images, while the remainder of the images does not need to show the same poses.
- The calibration grid used must show contrast in both the DIC calibration images and the external calibration image. For the case of an IR camera, this means using a grid that shows contrast in both the visible and IR spectrum. It does not matter if light and dark are reversed in the IR camera images compared to the stereo system.

Calibration of the external camera is performed by clicking *Calibrate... Calibrate External Camera* from the main menu. A file selection dialog will appear.

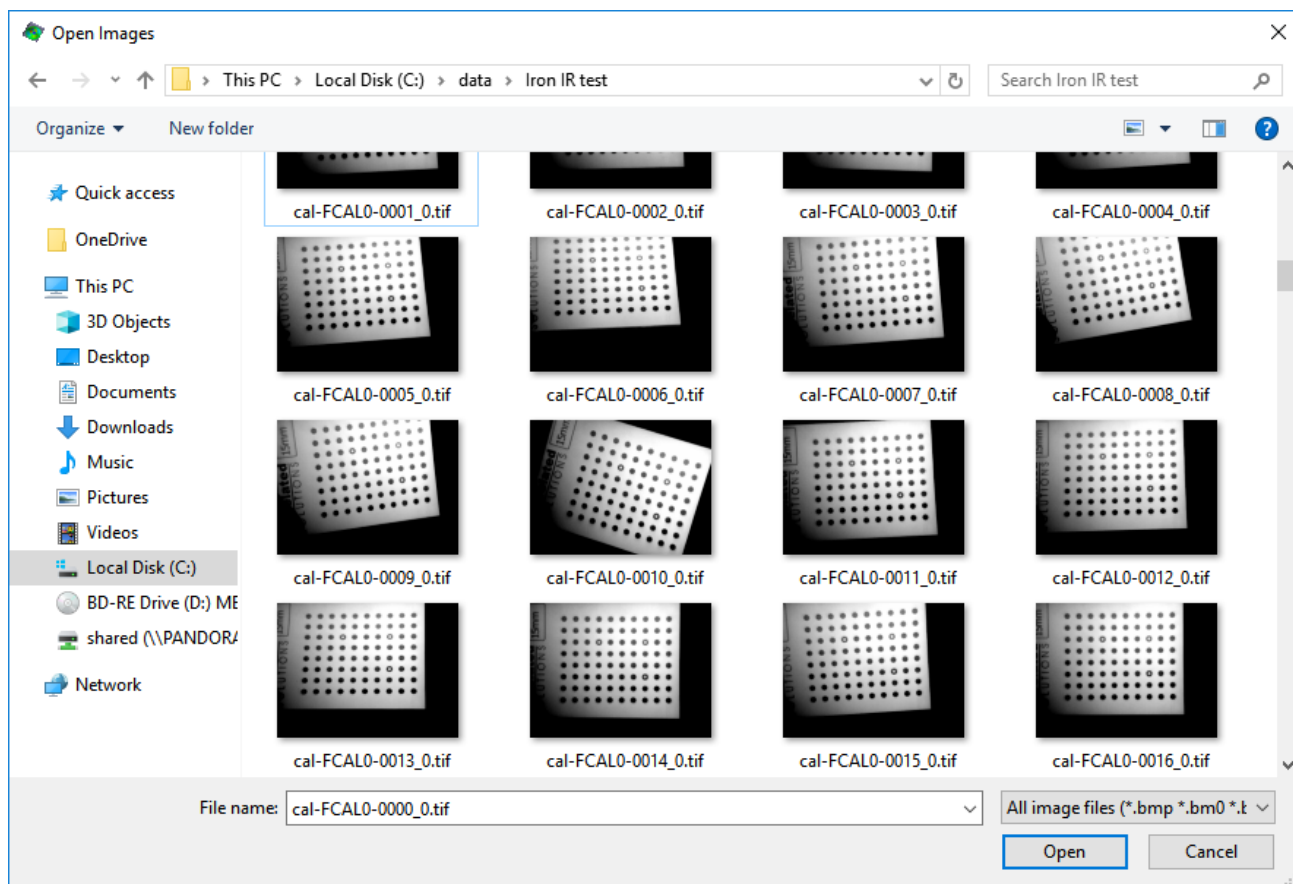

Figure 5.15: Image selection for external calibration.

In this dialog, the set of calibration images for the external camera must be selected followed by clicking the **Open** button. In the following dialog, a camera ID must be assigned to the external camera.

Multiple external cameras can be calibrated; select an ID, or when using a single external camera, simply click **OK**. A single-camera calibration dialog will appear.

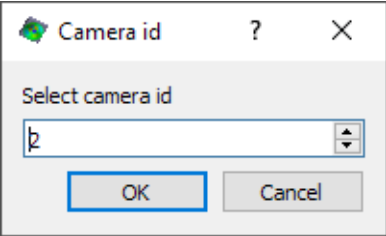

Figure 5.16: Camera ID for external camera.

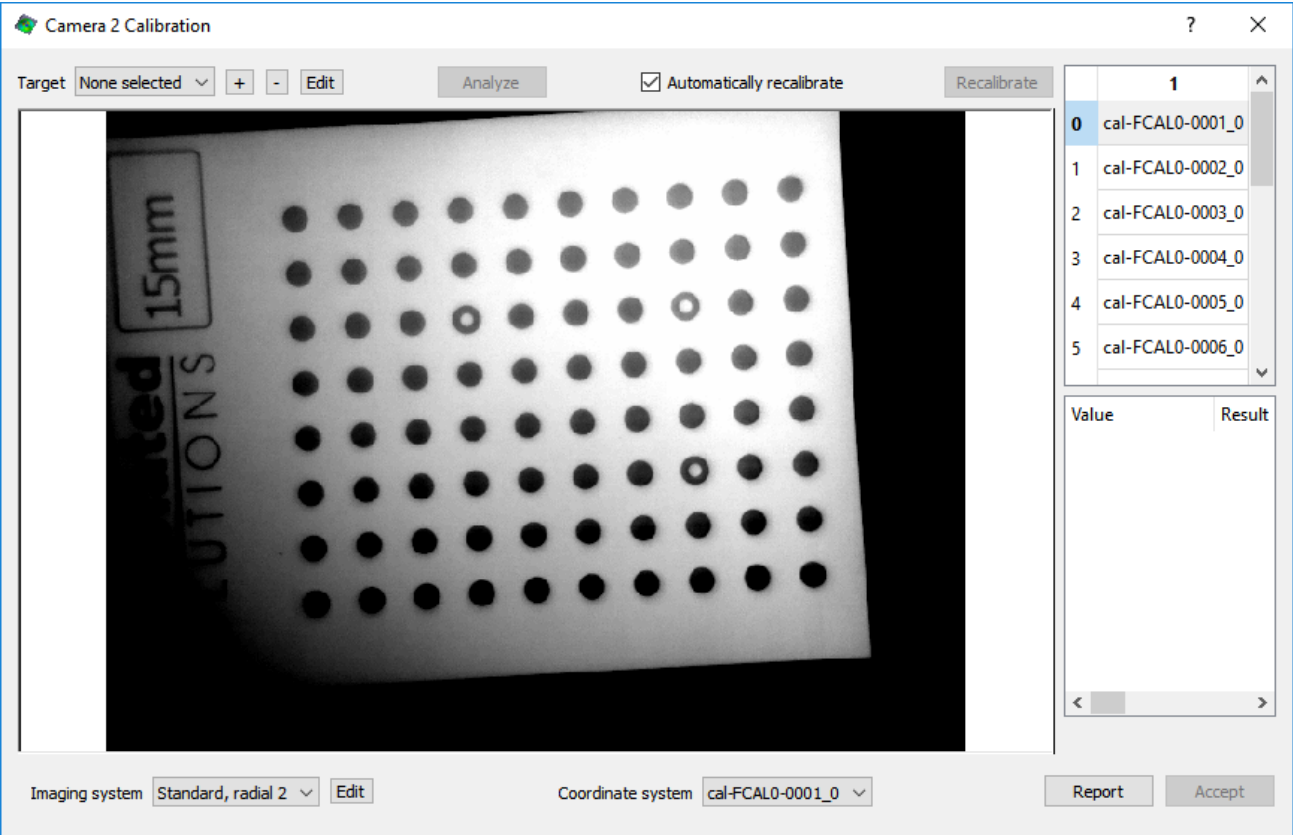

Figure 5.17: Calibration Dialog for External Camera

5.4.1 Calibration and Setting the Coordinate System

Calibration proceeds as usual (for details, see the [Calibration Dialog](#) topic), except that the coordinate system must be set by using the pulldown at the bottom right:

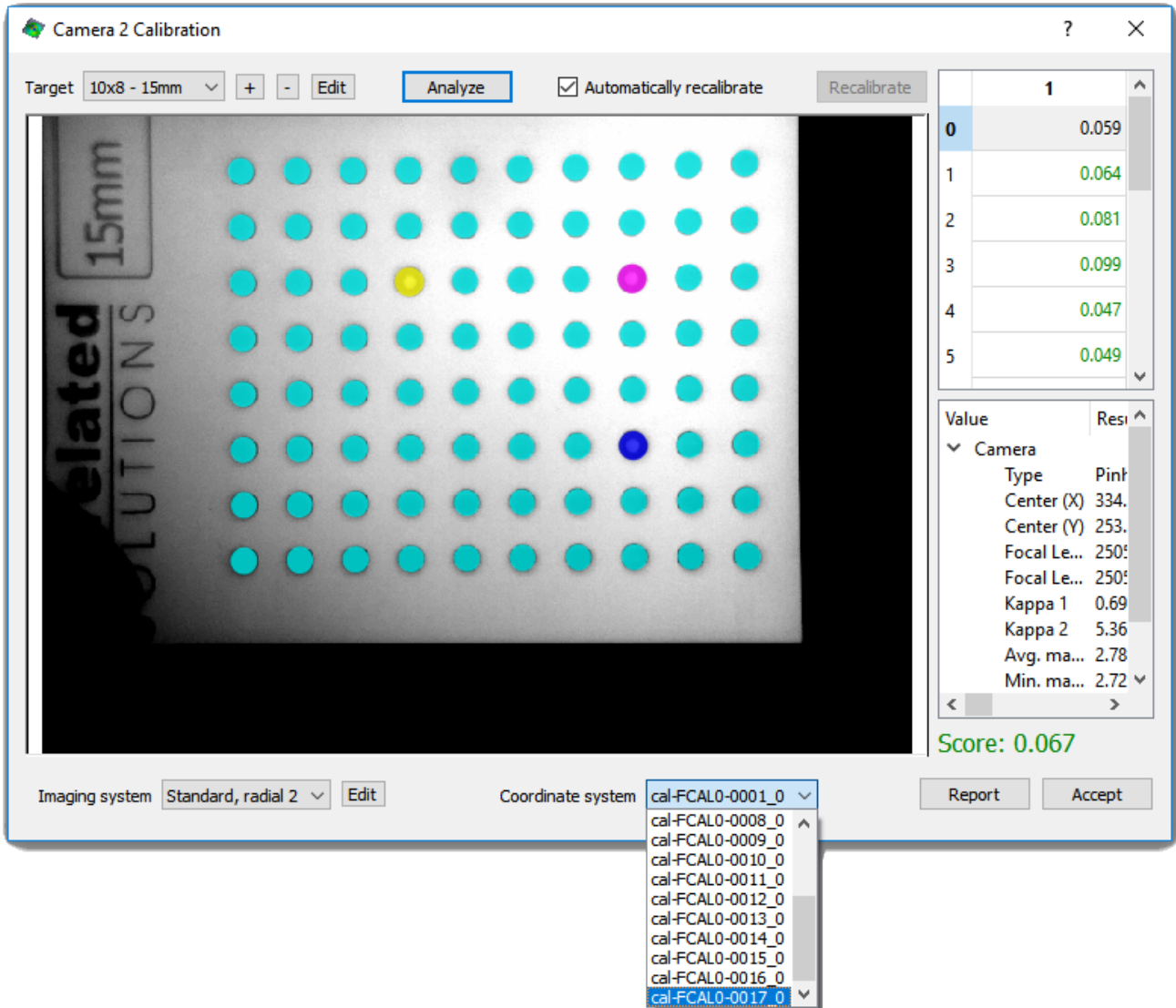

Figure 5.18: Setting coordinate system for calibration.

This **must** be the same grid orientation selected during stereo calibration; if a different or no orientation was set during stereo calibration, the stereo calibration must be repeated with the same orientation selected to define the coordinate system.

Once the calibration is complete, click **Accept**. To proceed with mapping the external data, run the correlation, and then use the [Map external data](#) postprocessing tool.

5.5 Adjustments for Cropping

For many applications, particularly in high-speed imaging, the images collected during the test may not have been acquired at full sensor resolution in order to increase the frame rate or to save disk space. This can pose serious difficulties for normal calibration procedures. For instance, if a dog-bone sample is used, it can be advantageous to reduce the size of the image in the short dimension of the sample. This can lead to images that are only a few tens of pixels in one dimension, and it is practically impossible to image a calibration target in this case.

For such applications, it is best to calibrate the camera at the full resolution of the sensor and only crop the images during the test. The crop dialog seen in the figure below permits adjustment of the calibration in such cases.

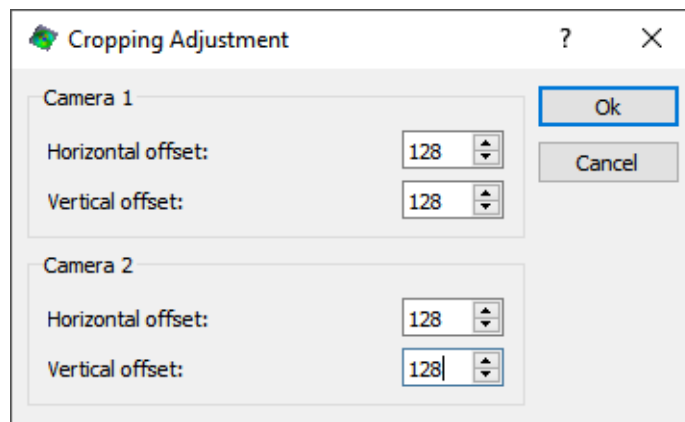

Figure 5.19: Crop adjustment dialog.

The dialog permits the user to enter the top-left corner of the image section with respect to the calibration images for both cameras.

- If a reference image is loaded during calibration with a different size than the calibration images, the adjustment dialog is automatically shown.
- The default values for the offsets are computed so that they are correct for most modern high-speed cameras that crop from the center of the sensor.
- For images taken with Vic-Snap, the correct values will be read from the TIFF metadata.

i New calibration parameters for camera 1 and 2 will change after clicking OK (the transformation parameters will not change). Please note that this task must only be performed once. After the calibration adjustment has been applied correctly, a much lower (and correct) projection error will result during the analysis.

5.6 Importing a Calibration

To import the calibration from an existing Z3D or V3D project file, select *Calibration... From project file* from the main menu bar. You will be prompted to select a project file; when complete, the calibration will be imported and added to your current project.



To generate a new project with a calibration from an existing project, it can be more convenient to use the *Project->New from template* function.

Chapter 6

Initial Guess Selection

In Vic-3D, initial guesses will be needed very rarely. Some instances where they may still be necessary include:

- Multiple, large camera angles (rather than a single stereo angle)
- Highly curved surfaces such as cylinders
- Large rotations between successive images
- Very fine or indistinct speckle patterns
- Poor calibration.

In the absence of these conditions, you can generally run the correlation immediately after selecting an AOI. If the correlation fails or runs very slowly, an initial guess may be needed.

i Even if an initial guess is not required, placing a start point in an appropriate location (see below) can make the analysis faster. This is the case even if the start point location is not pre-computed for all images before correlation analysis.

6.1 Placing Start Points

A start point may be placed by clicking the  icon in the Mask tools box from the AOI Editor. Once a start point is placed, Vic-3D will start looking for initial guesses in the background. If initial guesses are not automatically found, manual editing may be required.



i Generally, it is best to place a start point in the area of the image that undergoes the least amount of motion during the test. For instance, if a specimen is tested in a tensile frame, the start point should be placed as close to the stationary grip as possible. Placing the seed point this way will help ensure fully automatic correlation. If a specimen is expected to fail or crack, it may help to put start points on either side of the specimen so that once failure occurs there will still be a start point on both surfaces.

For very large transformations or rotations, it can be very helpful to place fiducial marks on the surface. This can be integrated into a printed pattern or simply drawn on the surface with a marker. These marks may be located much more easily than the random pattern especially if, i.e., one image is rotated 180 degrees from the other.

6.2 Editing Initial Guesses

The initial guess dialog may be accessed by double clicking on the  icon in the AOI editor, or right-clicking and selecting *Edit guesses*. The *Initial Guess Editor* dialog will appear.

The four windows on the left show the camera 0 and camera 1 reference images above, and the camera 0 and camera 1 deformed images below. The small windows at the upper right show the zoomed-in guess for the same four images. The list at the lower left shows all the deformed images; where a guess is already present, the marker will be green. A yellow marker indicates a guess exists for only one image of that pair, and a red marker means no guess exists.

A guess may be added by dragging the corresponding square from the stereo or deformed image until it is in the same spot as the reference camera 0 image (at top left). The images can be zoomed in and out with the mouse wheel, or by clicking the  icon and drawing a box; or by clicking the  icon to zoom into the current guess area. A histogram control is provided for the reference and deformed images. The red bars may be adjusted to control image balance; this can be useful for finding detail in very dark images. Double clicking the histogram will automatically set/reset the limits.

Below, the camera 1 image guess has been dragged to the approximate correct location:

The guess can be checked by clicking the  icon, or by right-clicking in the desired image:

If the correct match is found, a second right-click will accept it. If the match is not found, the guess can be moved and tried again. Where severe scaling or shear is present, the guess may need to be refined by adding control points or setting scaling/shear with the control nodes.

6.3 Initial Guesses from Corresponding Points

Initial guesses, including deformation components, can be set using corresponding control points.

Control points may be added to the reference image by clicking the  icon and then clicking on an easily identifiable image feature, e.g. the center of a speckle. Up to three points can be added:

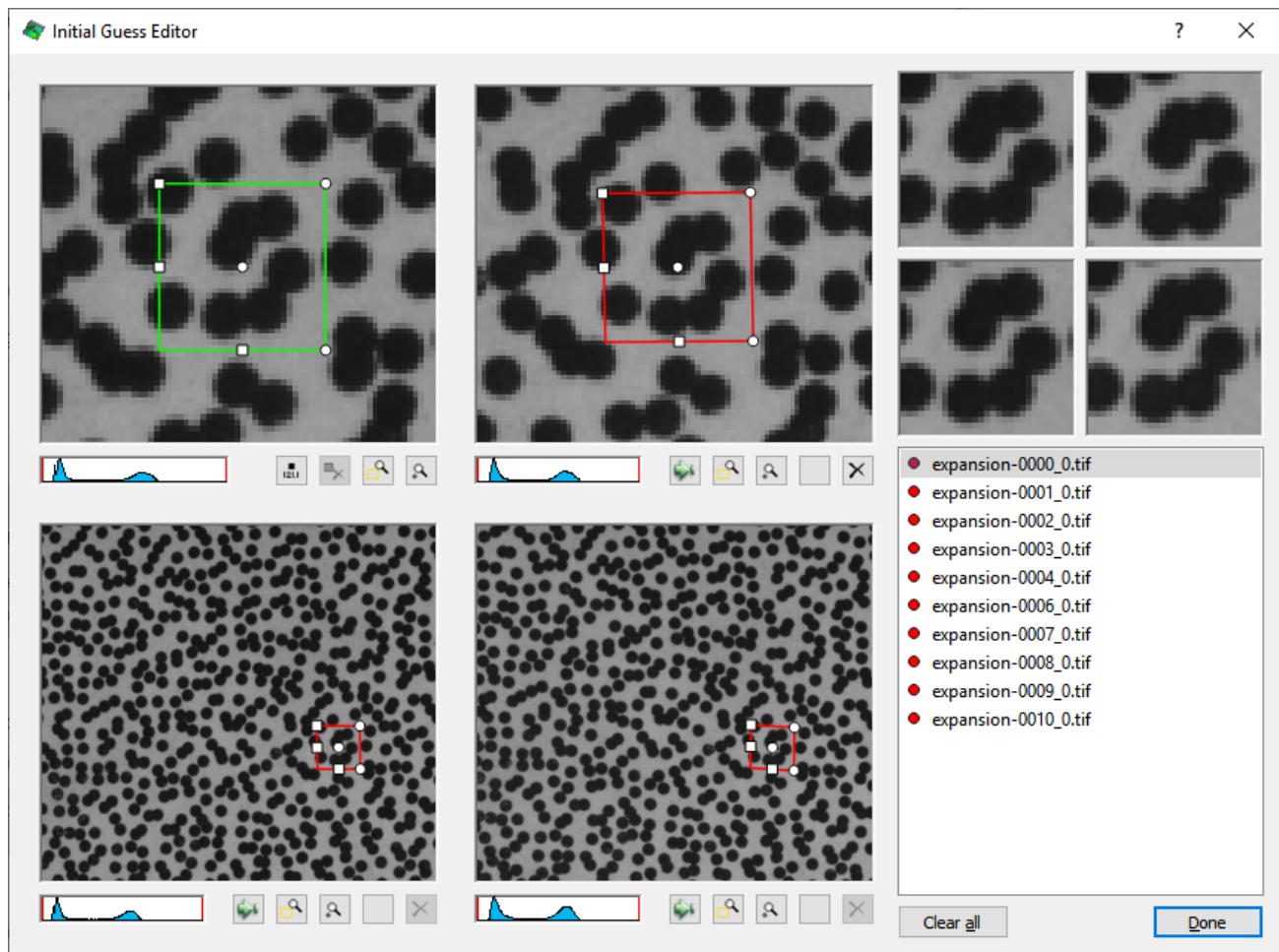



Figure 6.1: Initial guess editor.

The control point locations are automatically shown in the deformed views based on the current guess parameters. These points may be dragged to the correct location by clicking on them and then dragging the mouse while keeping the button pressed. Note that Vic-3D will not allow points that are too close together, or too close to colinear. Control points may be deleted by first clicking  and then clicking on the point to remove.

6.4 Initial Guesses from Subset Controls

Initial guesses may also be set by using the controls built into corners and edges of the subset. The upper left control point affects rotation; the left and bottom points control X and Y scaling; and the upper right and lower right points control shearing.

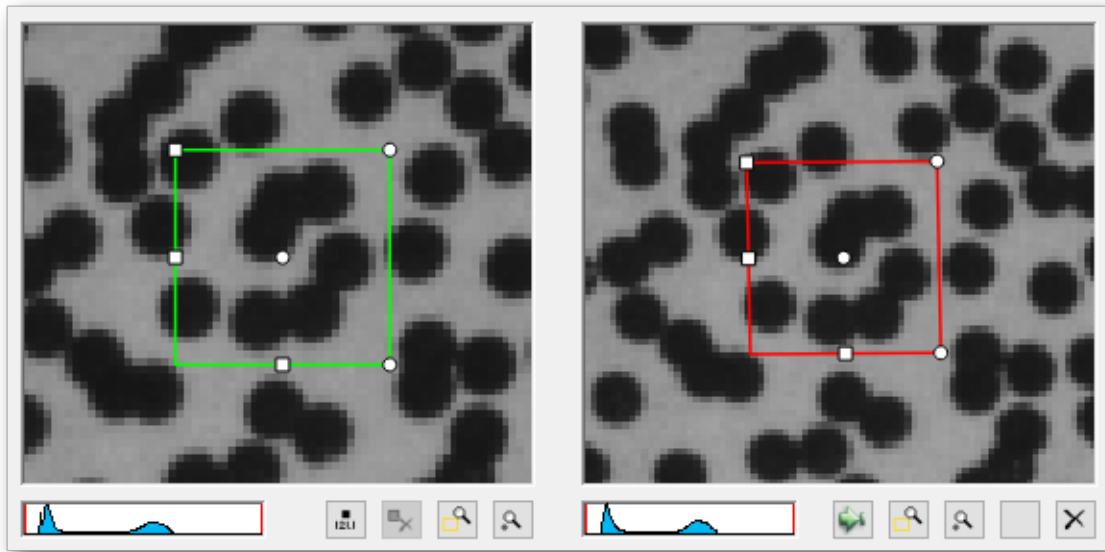

Figure 6.2: Approximate guess location.

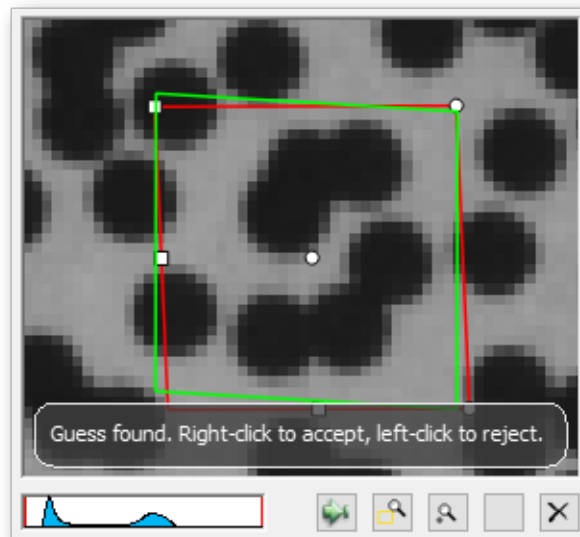

Figure 6.3: Initial guess found.

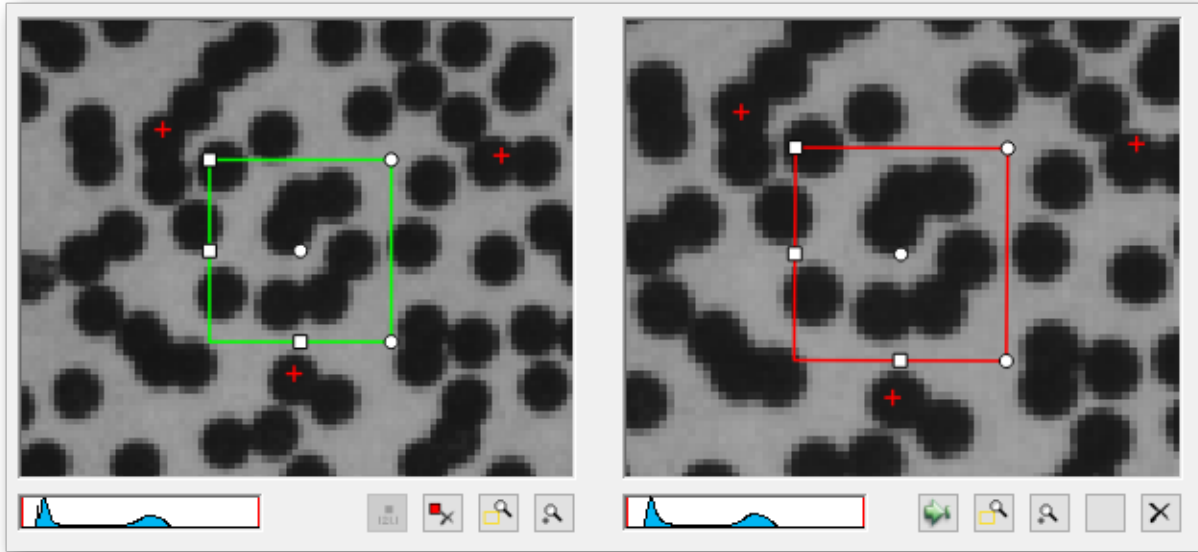

Figure 6.4: Setting control points.

i In most cases where a manual initial guess is required, a stereo guess (for the initial reference pair) will be sufficient to initialize the correlation. After a stereo guess is provided, the software can normally determine initial guesses for deformed images automatically during the correlation process. This works best if the translations and deformations are kept small between successive images. To that end, it is beneficial to use a high sampling frequency and to place start points in lower-motion areas (e.g., near the fixed grip in a tensile test) as described above.

6.5 Comparison View

While manipulating initial guesses, a comparison view showing the reference subset and the corresponding deformed subset (resampled based on the current guess parameters) is shown in the upper right-hand corner of the dialog. When the initial guess is correct (or close), the four patterns should look similar as shown in the figure below.

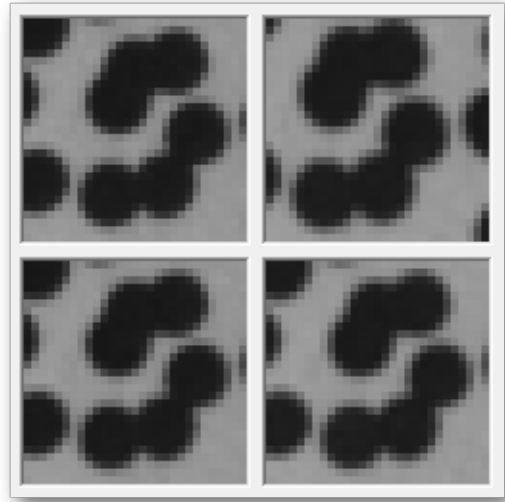



Figure 6.5: Comparison view of reference and resampled deformed subset.

Chapter 7

Running the Correlation

To run the displacement analysis, select the *Run Correlation* entry from the *Data* menu, or press the  button on the tool bar. The correlation can also be started with the keyboard shortcut CTRL+R.

7.1 The File Tab

The file tab on the analysis dialog is illustrated in Fig. 7.1. The name of the reference image is displayed at the top while the deformed images used for correlation are shown in a list box below.

7.1.1 Selecting Images

The deformed images to use for correlation analysis can be selected from the list box on the dialog. Selected images are indicated by a check mark. Above the list box, buttons are available to select/deselect all image files contained in the list box. To select 1 data file from every 2, 5, 10, or n , right-click in the file list and choose the desired option.

If no images are selected, only the reference image is analyzed.

7.1.2 Output Directory

The directory in which the output files are stored can be selected by clicking the folder icon.

7.2 The Options Tab

The tab on the dialog displays the following options:

7.2.1 Projected Speckle Mode

If this box is present, it can be selected to analyze images where the speckle pattern was projected rather than affixed to the surface. In this mode, each data point in the reference image is analyzed for X, Y, Z position. Then, for each deformed image, we again determine an X, Y, Z position

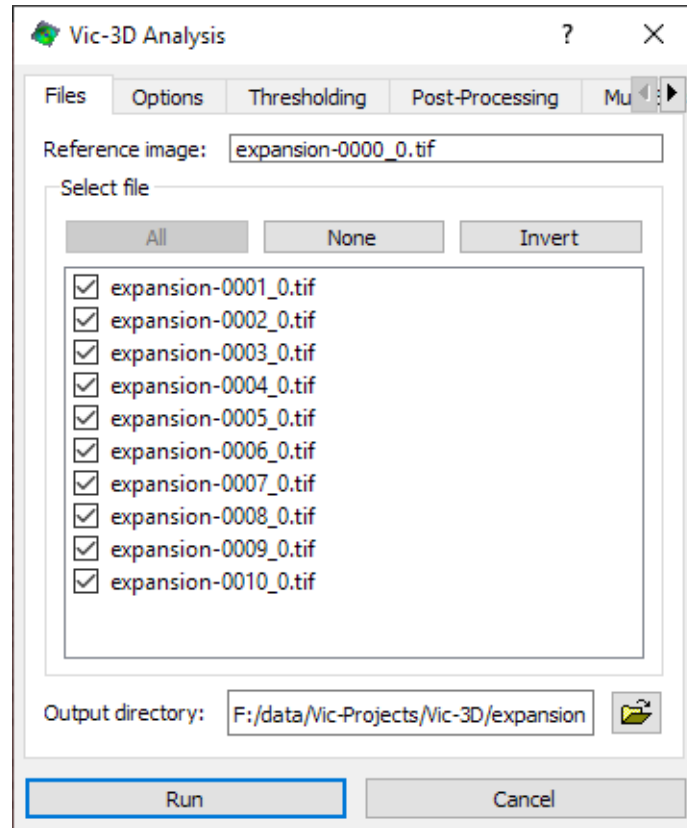

Figure 7.1: Analysis dialog file tab

for each data point; for a given data point, the difference between the reference position and the deformed position is calculated and this becomes the U , V , W displacement. At no time do we *track* a point from the reference image to a deformed image; each point is considered as a location only, and the location delta is calculated from the locations. Because of this, the pattern may be completely different from one image to the next.

In projected speckle mode, in-plane motions will not be recognized, because the speckle pattern does not stay with the surface. All displacements will come from shape change.

7.2.2 Differential Mode

This box will not be present, unless a module key for Differential mode is installed.

Differential mode compares each image to the next, and gives the differential U , V , W , and strain.



Differential mode can be used for continuously moving surfaces that leave the frame.

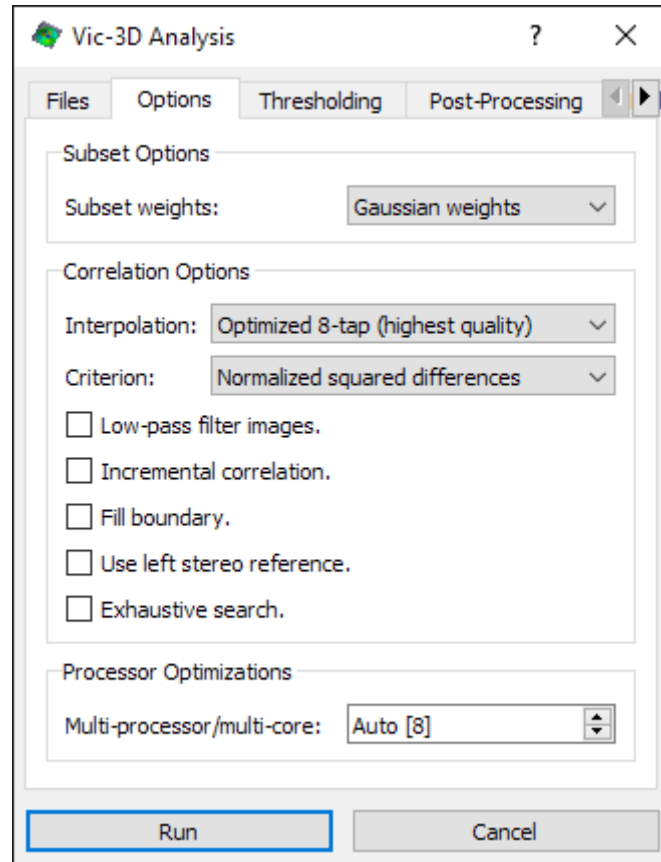

Figure 7.2: Analysis dialog options tab



Figure 7.3: Differential mode options tab

7.2.3 Subset Weights

This option controls the way pixels within the subset are weighted. With Uniform weights, each pixel within the subset is considered equally. Selecting Gaussian weights causes the subset matching to be center-weighted. Gaussian weights provide the best combination of spatial resolution and displacement resolution.

7.2.4 Interpolation

To achieve sub-pixel accuracy, the correlation algorithms use gray value interpolation, representing a field of discrete gray levels as a continuous spline. Either 4-, 6-, or 8-tap splines may be selected here.

Generally, more accurate displacement information can be obtained with higher-order splines. Lower-order splines offer faster correlation at the expense of some accuracy.

7.2.5 Criterion

There are three correlation-criteria to choose from:

- Squared differences: Affected by any lighting changes; not generally recommended.
- Normalized squared differences: Unaffected by scale in lighting (i.e., deformed subset is 50% brighter than reference.) This is the default and usually offers the best combination of flexibility and results.
- Zero-normalized squared differences: Unaffected by both offset and scale in lighting (i.e., deformed subset is 10% brighter plus 10 gray levels.) This may be necessary in special situations. However, it may also fail to converge (produce a result) in more cases than the NSSD option.

7.2.6 Low-Pass Filter Images

The low-pass filter removes some high-frequency information from the input images. This can reduce aliasing effects in images where the speckle pattern is overly fine and cannot be well represented in the image. (These aliasing effects are often visible as a moire-type pattern in the output data.)

7.2.7 Incremental Correlation

With incremental correlation, each image is compared to the previous image rather than the reference image. This can be useful in cases of pattern breakdown or extremely high strains (>100%). This comes at the expense of an increase in noise for later images, because the noise continues to add over each successive correlation. Note that the displacements are automatically integrated, i.e., the results are still in Lagrangian coordinates. This integration has the negative side-effect that non-random noise is integrated as well and can lead to significant error accumulation.



Due to error accumulation, it is not recommended to use incremental correlation.



If incremental correlation has to be used, it is recommended to first analyze an image sequence without incremental mode to determine at what point the correlation breaks down. The incremental mode can then be used to analyze only the images after that point in a second analysis. This is accomplished by deselecting the successfully correlated images except for the last one, see [Section 7.1](#) for details. An initial guess may be required for the last successfully correlated image when the intermediary images are deselected.

7.2.8 Fill Boundary

Checking this option will cause the analysis to produce data all the way out to the edge of the AOI. The data is interpolated from multiple subset gradients using an intelligent optimized algorithm. The resulting output data is compared in [Fig. 7.4](#).

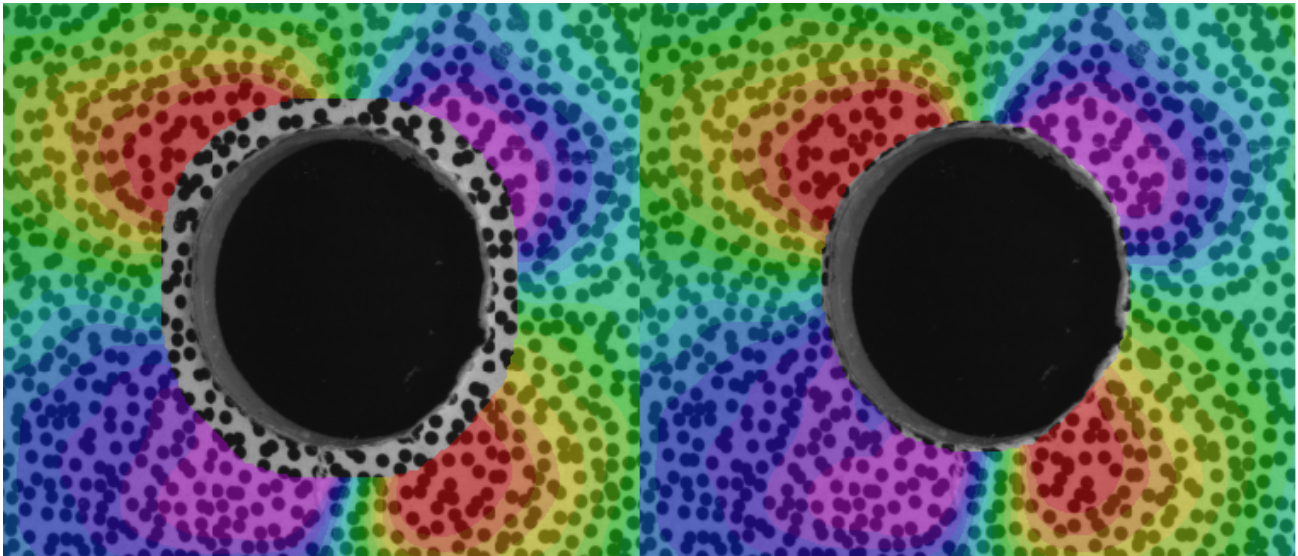

Figure 7.4: Fill boundary off, left, and on, right.

7.2.9 Use Left Stereo Reference

By default, Vic-3D compares the left to the right image only once: in the initial stereo pair. After this point, succeeding left images are compared to the left reference, and succeeding right images are compared to the right reference. This is illustrated on the left in [Fig. 7.5](#).

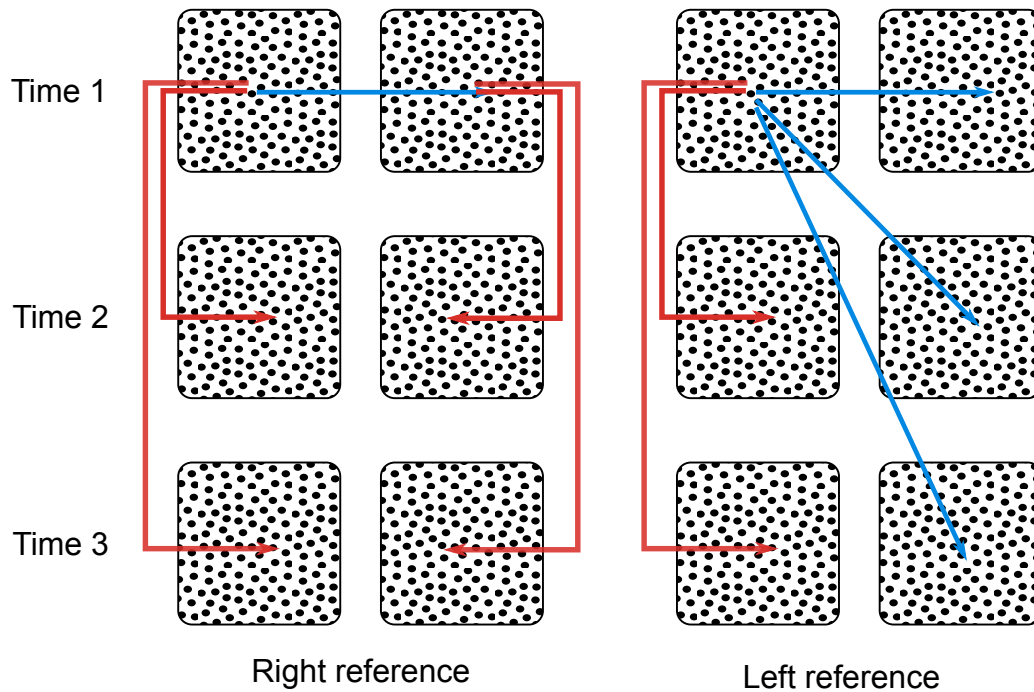

Figure 7.5: Illustration of which images are compared for left and right stereo reference.

In prior versions, both left and right images from any point in the sequence were always compared to the left reference image. Checking the “left stereo reference” box will force this latter behavior in Vic-3D 8 as illustrated on the right-hand side in Fig. 7.5.



While the right stereo reference normally provides better results for deformation analysis due to the better similarity between images taken by the same camera, there are situations where artifacts can arise, particularly at the boundary. After the stereo correspondence has been determined for the reference image, the software always uses a square subset in the right reference image located at the center point found in the disparity analysis. It is possible that this subset overhangs the object at the boundary if the perspective transformation results in significant compression of the subset between left and right camera, which is the case, e.g., at the edges of cylinders. In such situations, it is best to trim the AOI to avoid the overhang or to use the left stereo reference.

7.2.10 Exhaustive Search

Enabling this option will cause Vic-3D to repeat a coarse search for matches after each time the correlation fails. This may result in more data recovery at the expense of vastly increased processing time.

7.2.11 Processor Optimizations

This option controls the number of processors/cores Vic-3D uses for analysis. If the spin box is set to its minimum value, [Auto] and the number of logical processors present will be displayed, and this preference will be stored in the registry.

i Due to the multi-threaded and path-dependent nature of the analysis algorithm, multi-processor analysis will return very slightly different results from one run to the next. The difference is well under the precision of the algorithm and will not produce any meaningful difference in strain or displacement results.

7.3 The Thresholding Tab

This tab provides options for removing any data that is bad or suspect while maximizing the amount of retained data. Four thresholding options are available. For a typical test, the default values will work very well, but when conditions are unusual or substandard (blur; debris; poor lighting; etc), some adjustment may be required.

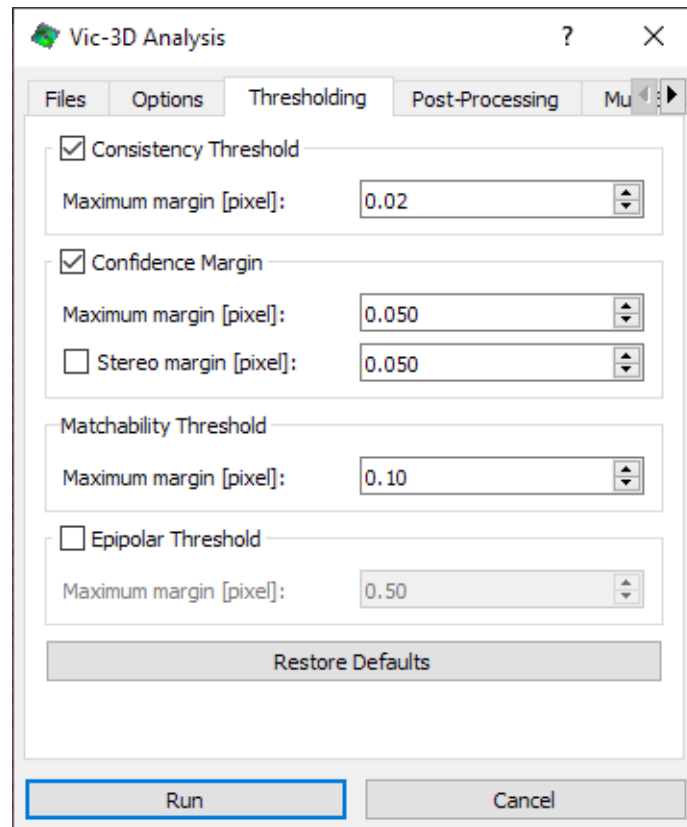

Figure 7.6: Analysis dialog thresholding tab

7.3.1 Consistency Threshold

After Vic-3D analyzes the seed point, the analysis is propagated to each of its four neighbors, and so on. Each point is fed with a prediction of its approximate match. After the match is made, a *back*-prediction is calculated. If the back-prediction does not closely match the actual location of the prior neighbor, this threshold will remove the data.

7.3.2 Confidence Margin

For each match, Vic-3D calculates a statistical confidence region, in pixels, using the covariance matrix of the correlation equation. If the confidence region exceeds this threshold, the data will be removed. The confidence margin corresponds directly to the noise in the image matches (at least for low noise levels).

7.3.3 Matchability Threshold

This option automatically removes subsets that show a very low contrast, i.e, subsets that don't contain very much information. Decrease this value to remove more data; increase to retain more data, i.e., if lighting conditions were poor.

7.3.4 Epipolar Threshold

For a stereo system, the match for a point in one image must theoretically be found on a line in the other camera's image. This line is called the *epipolar line*. If a calculated match does not lie very close to the epipolar line, this threshold removes the data. The epipolar threshold can also be thought of as a limit on the projection error. High projection error may be caused by motion blur, synchronization issues, a poor calibration or cameras which are not rigidly mounted.

7.4 The Post-Processing Tab

The post-processing tab on the analysis dialog is shown in Fig. 7.7. This tab controls whether an automatic plane-fit is applied to the data and whether metric confidence margins and strains are computed or not.

7.4.1 Auto Plane Fit

Checking this option will create a coordinate system based on the reference shape. The origin will be at the mass centroid of all measured points, with the Z-axis normal to the best-fit plane of the data field.

Leaving this option cleared will return results in camera coordinates. If custom coordinate transformations are to be used, you should always start with camera coordinates to establish a consistent Cartesian reference frame rather than one that may move based on the data.

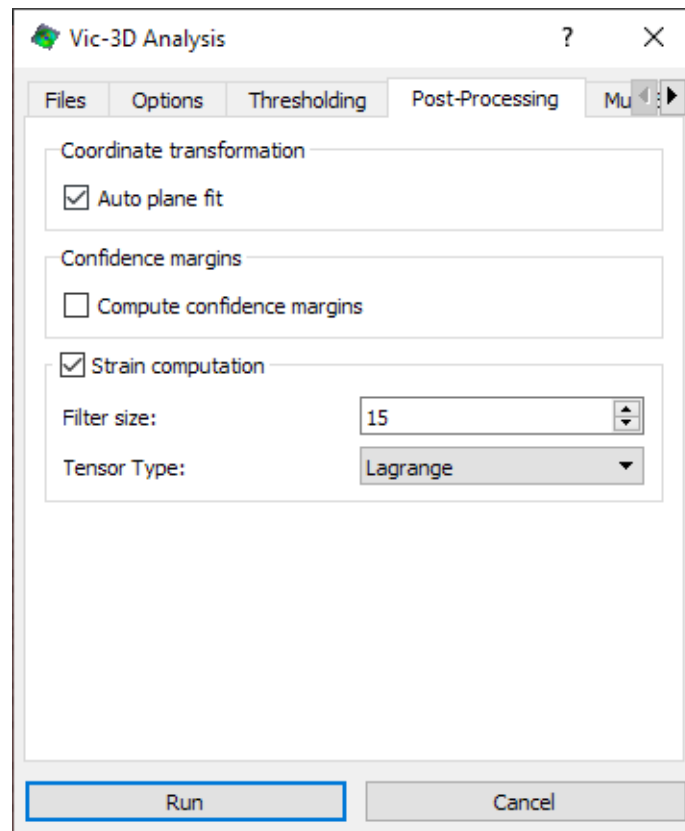

Figure 7.7: Analysis dialog post-processing tab

7.4.2 Compute Confidence Margins

Check this box to add metric confidence margins for X, Y, and Z position and displacement. The new variables represent the 1-standard-deviation confidence for the position, computed from the pixel confidence margin together with the camera geometry.

7.4.3 Strain Computation

Checking this option performs a strain computation as each image is processed; results can be viewed in the preview.

7.5 The Multi-System Tab

The multi-system tab on the strain dialog is illustrated in Fig. 7.8. When the *Multi-System Correlation* check-box is checked, a different calibration can be used for the deformed images while the main project calibration is still used for the reference image. This can be used for correlating from one stereo pair to another pair, i.e., for registering overlapping patches around a cylinder (see Section 9.4.2 for details). It can also be used when the system must be recalibrated between reference and deformed images.

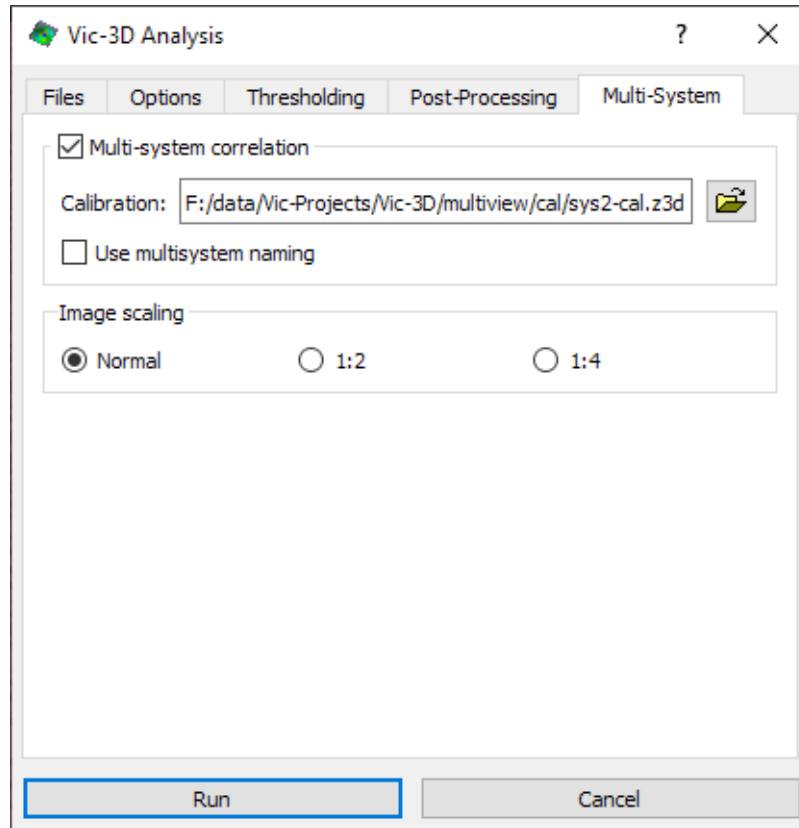

Figure 7.8: Analysis dialog multi-system tab

Multi-System Correlation

This check-box is used to enable and disable multi-system mode.

Calibration

Click to select the project file containing the deformed calibration.

Use multisystem naming

If this option is checked, deformed output files will be named differently. If the input files are multisystem files generated by Vic-Snap (sys1, sys2, etc), the output files will be named for the two systems - for instance, trans_sys1_sys2.out. If the input files do not contain a system number, the output file will be named after the reference and deformed images - for instance, trans_reference_deformed.out.

Image scaling

For completing global-local type tests, it may be helpful to work with images which are scaled down by a factor of 2 or 4. If your deformed images have been scaled this way, select the appropriate factor; normally, this option will be left at **Normal**.

7.6 Correlation Results

After starting the correlation, progress information is provided with a preview plot and a progress bar as illustrated in Fig. 7.9. The plot can be manipulated through a context menu by

right-clicking, see [Section 12.3.1](#) for details.

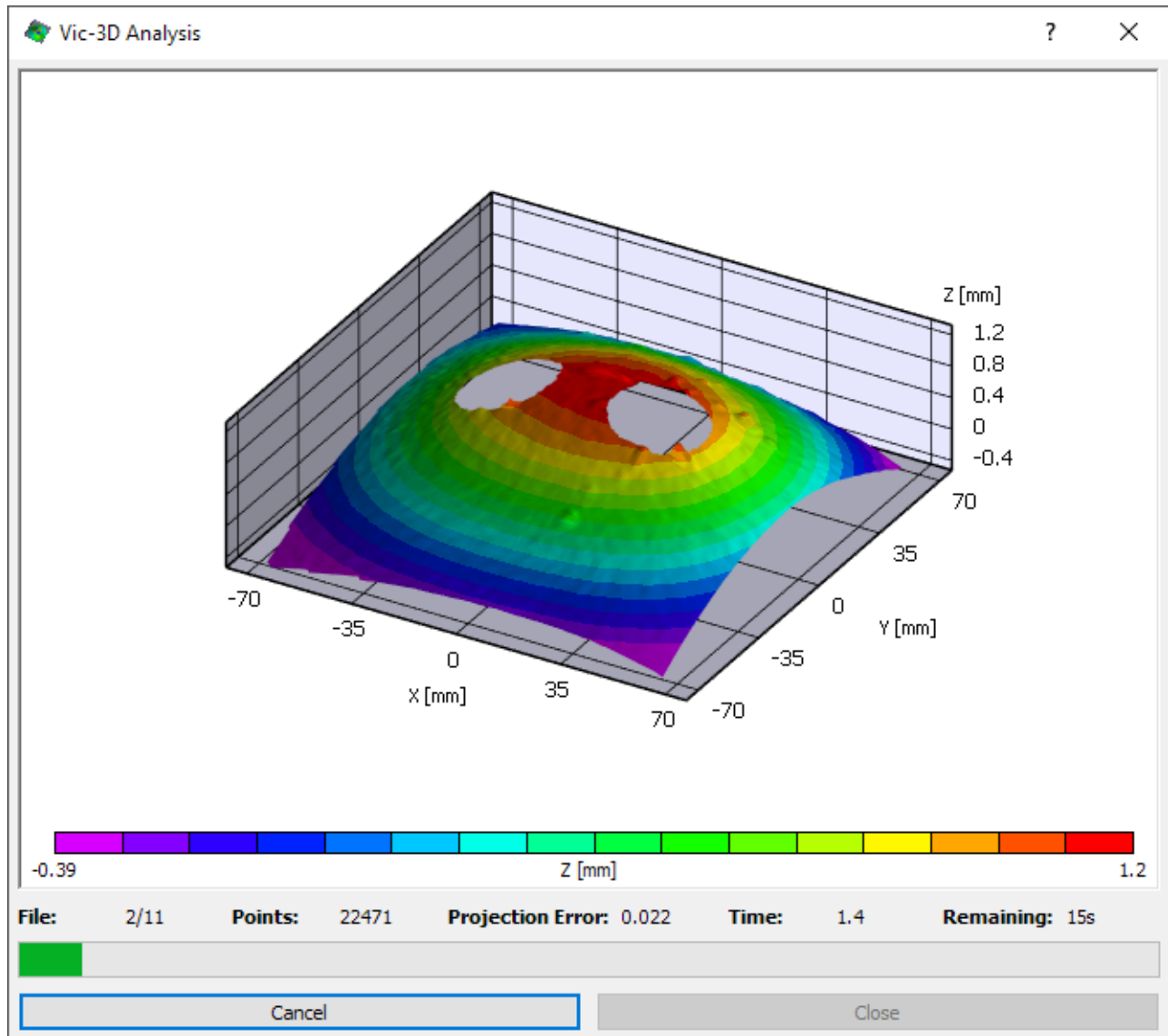

Figure 7.9: Analysis progress during correlation.

The window contains an overview of correlation progress and results.

File The progress and total number of files to analyze.

Points

The number of data points calculated for the image.

Time

The amount of time spent on correlation analysis in seconds.

Error

A measure of correlation accuracy (specifically, epipolar projection error). A high number indicates possible problems with calibration or camera synchronization.

Iterations

A measure of how many possible matches were searched for each point.

Progress bar

Indicates the progress of each individual file as it is correlated.

This window also contains a preview of the output data. This data may be view in 2D and 3D and manipulated as with a standard [plot](#).

When the analysis is complete, a summary of the above data for all images analyzed can be viewed by clicking on the *View Report* button, see Fig. 7.10 for an example. The report may be saved as a CSV by right-clicking and selecting *Save Report*.

	File	Points	Time	Iterations	Error
1	expansion-0000_0.tif	22471	2.478	1.8	0.020
2	expansion-0001_0.tif	22471	1.362	1.5	0.022
3	expansion-0002_0.tif	22471	1.502	1.6	0.026
4	expansion-0003_0.tif	22471	1.431	1.6	0.023
5	expansion-0004_0.tif	22471	1.450	1.7	0.025
6	expansion-0005_0.tif	22471	1.660	1.7	0.025
7	expansion-0006_0.tif	22471	1.684	1.8	0.021
8	expansion-0007_0.tif	22471	1.704	1.8	0.027
9	expansion-0008_0.tif	22471	1.783	1.8	0.025
10	expansion-0009_0.tif	22471	1.724	1.9	0.018
11	expansion-0010_0.tif	22468	2.065	1.9	0.010

File: 11/11 **Points:** 22468 **Projection Error:** 0.010 **Time:** 2.1 **Remaining:** 0s

[View Plot](#) [Close](#)

Figure 7.10: Analysis report after calibration.

7.7 Troubleshooting Analysis

There are a few potential explanations when no points are found during the analysis.

- An initial guess is needed: Vic-3D will attempt to automatically determine a good start point and to find the match in the other stereo image. This algorithm usually works well but if the pattern is dark or indistinct, or if the calibration is imperfect, it may fail. In this case, you can manually place a [start point](#) using the AOI tools. Often, simply placing the start point on a clear, recognizable feature will be enough; if it is not, you can provide a [manual initial guess](#).
- Thresholds are set too low: You can control how much data is removed using the [Thresholding](#) tab of the Analysis dialog. The defaults are generally good, but in some cases they may remove all data. A common case would be that the calibration has been disturbed, and this is causing the Epipolar Threshold to remove all data. Try turning off or increasing thresholds to retain more data.
- Image is too dark: Vic-3D can work with images which are fairly dim but a bright image - just on the edge of being overdriven, but not quite - will give the best results. Check that the area of interest is bright and even in both camera images. Provide an initial guess, if necessary.
- Image is defocused: Severe defocus can cause correlation to fail; check the the image is sharp across the entire area of interest, in both cameras. Provide an initial guess, if necessary.

Chapter 8

Batch Processing Dialog

To batch process multiple project files, the *Batch Analysis* entry in the *File* menu can be used. This will display the dialog shown in Fig. 8.1. This dialog can allow to queue multiple projects along with optional report templates for analysis.

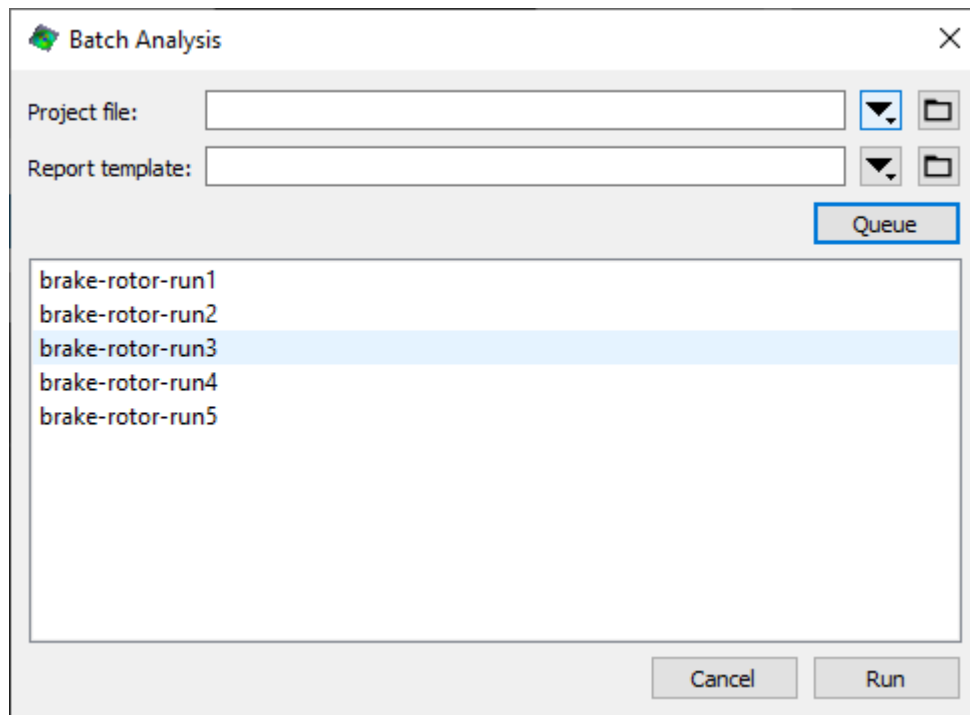

Figure 8.1: Batch dialog.

8.1 Queuing Projects

Projects can be added to the processing queue conveniently by pushing the arrow button in the top right. This displays a menu with recent projects to choose from. To queue a project that is

not present in the recent files menu, the folder icon can be pressed to select the project file via a file dialog.

An optional report template can be added in the same manner. After all images in a project have been analyzed, the report template is used to generate a report.

Projects can be removed from the queue by selecting them in the listbox and pressing *Delete* or *Backspace*.

Once all projects have been queued, the analysis can be started by pressing the *Run* button.

8.2 Batch Analysis

After the analysis has been started, the dialog will display the current project being analyzed with a progress bar indicating what percentage of the images has been processed. Below the progress bar, a log window provides additional information, e.g., the number of points, projection error as well any potential errors that might occur. An example of the dialog during analysis is shown in Fig. 8.2.

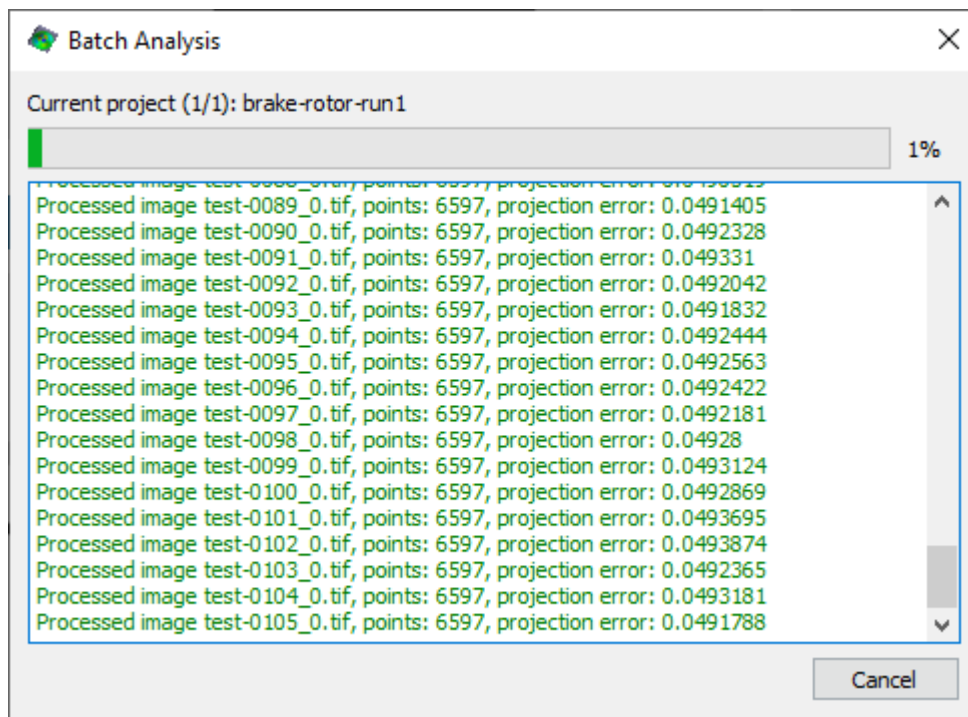

Figure 8.2: Batch dialog.

Chapter 9

Coordinate Systems and Transformations

The coordinate system in which the measured data is presented can be selected in a variety of ways. If no user selection is made, the default coordinate system is determined from the stereo transformation between the cameras. The origin is placed at the mid-point of the stereo rig's baseline and the X-axis coincides with the baseline. A common transformation is to use an automatic plane fit to the reference image, which can be enabled in the post-processing options of the analysis dialog (see [Section 7.4.1](#) for details).



The auto-plane fit option results in a data-dependent coordinate system. If the data has to be registered to other data, e.g., a second stereo system, finite element data or a world coordinate system established externally, the auto-plane fit option must be turned off.

The following tools are available for establishing coordinate systems and applying them to data sets:

- **Apply transformation** - apply a previously saved transformation to selected data files
- **Set coordinate system** - set the default coordinate system to a previously established system.
- **Best plane fit** - fit the data to the approximate plane of a selected data file
- **Select coordinate system** - select an origin, X- or Y-axis direction, or XY plane
- **Import from project file** - bring in a transformation saved in a different Z3D or V3D project file
- **Input manually** - enter a transformation in terms of angles, or specify a transformation matrix
- **Rigid transformation from displacements** - calculate a transformation from the displacement between two images. This can be used to register multiple DIC systems that have an area of overlap.

- **Compute cylinder transformation** - select a polar coordinate system, for nearly cylindrical surfaces
- **Apply cylinder transformation** - apply a saved polar coordinate transform
- **Multi-view registration from rigid motions** - register two or more Vic-3D systems into a common coordinate system based on rigid motions of a speckled object.
- **Coordinate system from markers** - determine a coordinate system from known fiducial points.

9.1 Coordinate System Selection

Coordinate system transformations can be selected based on the 3D data contained in the reference data file.

 To efficiently use coordinate transformations, make sure to disable automatic transformation during data analysis; see [Section 7.4.1](#) for details.

A new coordinate system may be chosen by selecting *Data... Coordinate tools... Select coordinate system* from the main menu bar.

The following dialog will be displayed:

9.1.1 Selection Method

9.1.1.1 Best-Fit Plane

This option may be selected to calculate a transformation into the best fit plane of the surface. This is identical to selecting Best Plane Fit from the coordinate tools menu.

9.1.1.2 Select Origin

This option may be used to designate an origin for the coordinate system, leaving the orientation unchanged. Simply click Select Origin, and pick a point in the image. This point becomes 0,0,0 in the x,y,z coordinate system. The orientation of the axes will be determined from the best plane fit.

 This transformation is useful when a specific point in the image is a convenient reference origin, for example, a notch in the specimen.

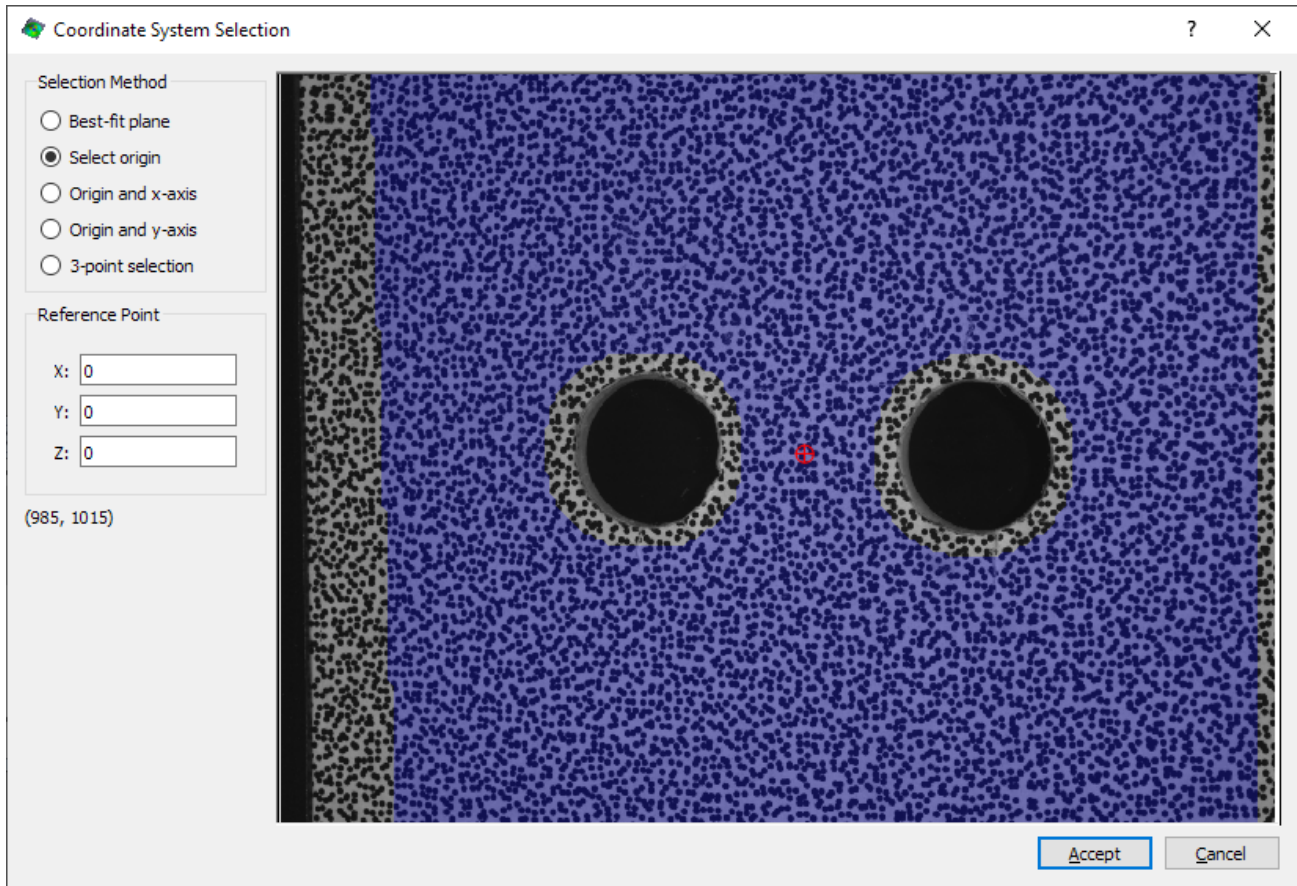

Figure 9.1: Coordinate system selection dialog.

9.1.1.3 Origin and X-Axis

Selecting this option allows the designation of the coordinate origin as well as the x-axis. After selecting, the first point clicked in the image becomes the coordinate origin. The second point clicked indicates the direction of the positive x-axis. The direction of the z-axis will be determined from the best plane fit, and the new y-axis will be normal to both.



This transformation is useful when both a specific origin point and an orientation are desired; for instance, the origin could be a crack tip and the axis could be the direction of the crack opening.

9.1.1.4 Origin and Y-Axis

This is a convenience function, identical to the above except that the Y-axis is chosen.

9.1.1.5 3-Point Selection

This option allows selection of an origin and the complete orientation of the axes. The first point selected becomes the origin. The second point clicked determines the direction of the X-axis. The final point defines the third point on the new XY plane, completing the coordinate system definition.

9.1.2 Reference Point

If desired, a coordinate may be designed for the reference point, other than the (0, 0, 0) Cartesian origin.

Clicking Accept will cause the new coordinate transformation to be calculated. The following dialog will appear:

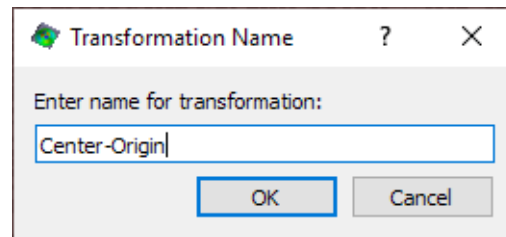

Figure 9.2: Coordinate system name dialog.

The transformation will be saved under the name entered. At this point a prompt appears, allowing immediate application of the transformation.

9.2 Applying Coordinate Transformations

There are two methods to apply coordinate transformations. The first method is used to set the coordinate system of the project, while the second method is used to transform existing data into a different coordinate system.

9.2.1 Applying Transformations to Projects

To set the coordinate system of a Vic-3D project, the menu entry *Data.. Coordinate tool.. Set Coordinate System* can be used. Selecting this entry results in one of the following actions:

1. If there is no transformation stored in the project, a prompt is displayed that gives the option to use a transformation stored in a different project file. If this option is confirmed, a file dialog is displayed to select the project file that contains the desired transformation.
2. If the project contains coordinate transformations or after a different project file has been selected in step one above, a dialog is displayed to select the coordinate transformation that is to be set as the new project coordinate system.

Once the coordinate system has been selected, it is then applied to the camera extrinsic parameters so that future correlation analysis and retriangulations will produce data in the selected coordinate system.



This method does not apply a transformation to any data that already exists in the project. To retriangulate existing data in the new coordinate system, the *Restore/Retriangulate* post-processing function can be used as described in [Section 10.4](#).

9.2.2 Applying Transformations to Data

Coordinate system transformations can be applied to data files by selecting the *Apply Transformation* entry from the *Coordinate System Transformation* menu. The following dialog allows choosing which transformation to apply, and which data files to apply the transformation to.

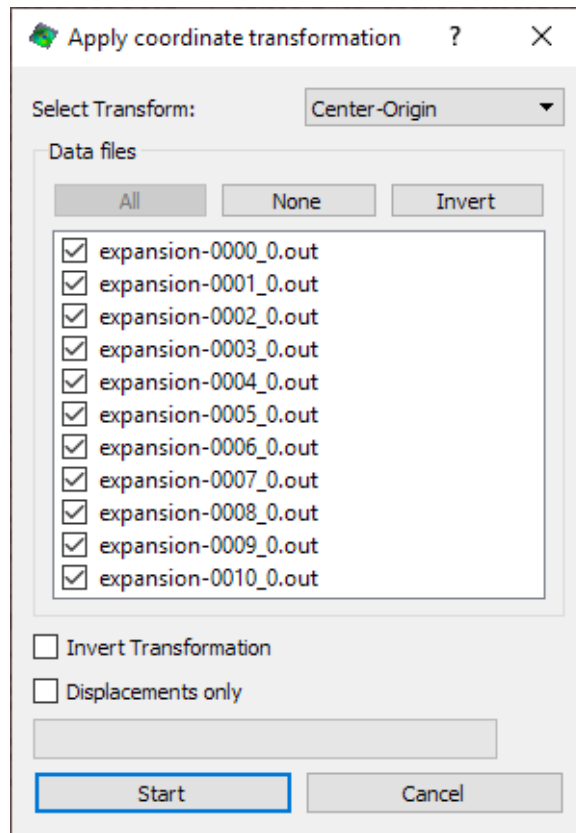

Figure 9.3: Apply coordinate transformation dialog.

The selected transformation may be inverted (undone) by checking *Invert Transformation*.

Each transformation contains 3 rotation components and 3 translation components. By default, only the rotation is applied to the U, V, and W displacement variables; that is, the displacement vectors are rotated with the surface, but their magnitude is unchanged. If

Displacements only is checked, the translation components will be applied as well, altering the displacement vectors' magnitude.



If strains are present in the input data, a warning will appear indicating that they will not be transformed. It will be necessary to recalculate strain for the x and y components to be correctly aligned with the new coordinate system.

9.3 Cylindrical Coordinate Transformations

Cylindrical coordinate transformations may be calculated by selecting *Data... Coordinate tools... Compute cylinder transformation* from the main menu bar.

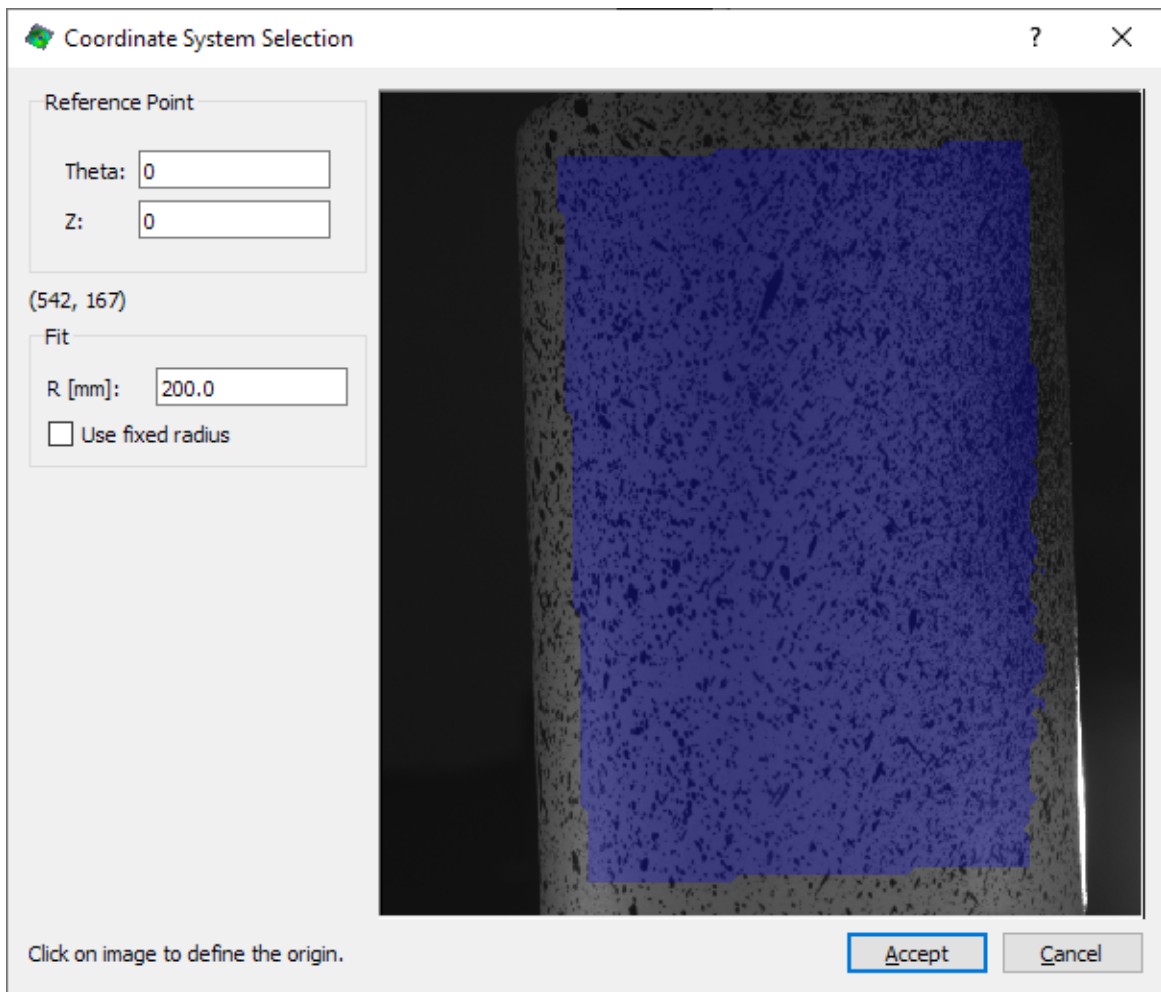

Figure 9.4: Cylindrical coordinate dialog.

A polar cylindrical origin in Z and Θ may be selected by clicking in the blue data region of the image. If a reference coordinate other than ($\Theta = 0, Z = 0$) is desired, values may be entered in the *Reference Point* box.

A cylindrical fit will be automatically determined by the software. An initial radius guess may be entered in the R [mm] box; this radius may be forced by clicking *Use fixed radius*.

i The fit will normally succeed without entering a radius. If the data is very sparse or ill-formed, entering a radius may become necessary.

The calculation is completed by clicking **Accept**.

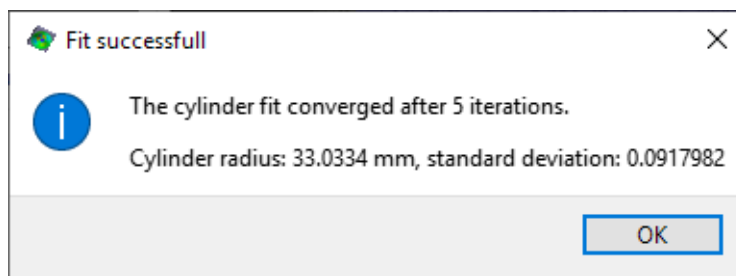

Figure 9.5: Cylindrical coordinate result.

The calculated radius and standard deviation are displayed. Click **OK** to name the transformation, and optionally apply it to the data.

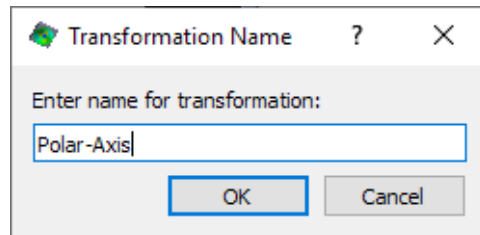

Figure 9.6: Cylindrical coordinate name.

New variables R , Z (*cylinder*), and Θ as well as dR , dZ (*cylinder*), and $d\Theta$ will be added to the results. These indicate the radius (distance from the polar axis), axial coordinate, and rotation angle (in radians).

i Applying a cylindrical coordinate transformation also applies a Cartesian transformation, the effect of which is to align the cylinder axis exactly with the Cartesian y -axis. Once strain is recalculated, the E_{xx} strain will be identical to the hoop strain, and the E_{yy} strain will be identical to the axial strain.

9.4 Coordinate Systems Registration

For certain applications, it is required to register Vic-3D data to a known coordinate system. The known coordinate system could be given by a second Vic-3D system, or it could be given by the test article (e.g., the lower left-hand corner of a beam) or even by a finite element model. There are different methods to accomplish this task, and the preferred method will depend on the application. In order of most accurate to least accurate registration, the methods available in Vic-3D are

1. Registration using rigid body motions.
2. Registration using overlapping regions between adjacent Vic-3D systems.
3. Registration using known marker locations.

The first method uses a sequence of images where a rigid object that is visible in all systems that are to be registered is translated and rotated. This is similar to a sequence of regular calibration images. There does not need to be any overlap in the field of view of the systems, but a speckle pattern must be visible in all systems that need to be registered. This method provides the best accuracy and the analysis procedure is no more difficult or time consuming than the second method.

The second method, using overlapping regions between adjacent Vic-3D systems, has the advantage that a single image is sufficient and no object motions are required. This comes at the expense of accuracy and only works if the systems have a sufficiently large overlap. The analysis requires that a correlation be performed from one system to the other, and finding an initial guess for this analysis can sometimes be challenging.

The third method, using known marker locations, only requires a single image in which the markers are visible and the image analysis is straightforward, particularly if the marker locations are available in a text file already. Due to the limited accuracy of this method, it is only recommended for registering data to external coordinate systems, e.g., finite element data.

The following sections describe each of the methods in more detail. The most common mistake when registering coordinate systems is to forget to turn off the auto plane-fit mode when analyzing the data, see [Section 7.4.1](#).

9.4.1 Registration from Rigid Body Motions

The process of registering multiple Vic-3D systems into a common coordinate system using rigid body motions involves the following steps:

1. Set up Vic-Snap for multi-system acquisition or, if not using Vic-Snap, name the image files with an identifier `-sysN-` before the image number, where N is the system number.
2. Acquire calibration images for each system.
3. Acquire synchronized images of a rigid object with a speckle pattern visible in each system. This sequence should contain the maximum rotations possible within the depth-of-field.
4. Create a project for each system and perform a calibration and an analysis of the motion sequence and ensure that **auto plane-fit is turned off**.
5. Use the multi-view registration dialog to determine the coordinate transformations between the systems.

6. For each system, set the coordinate system found in the previous step as the default system and store the project.

More details of the experimental procedure can be found in an application note. This section addresses only the last two steps of the analysis process.

9.4.1.1 Computing Transformations

The computed coordinate transformations will be relative to a reference system, which is determined by the project that is used to compute the transformations. Typically, this would be system 1, so the following steps are normally carried out with the project file of system 1 open in Vic-3D. The multi-view registration dialog can be opened by using the menu entry *Data... Coordinate tools... Multi-view registration from rigid motions*. This will show the dialog illustrated in Fig. 9.7 if the file naming is consistent with a multi-system project and the data files from other systems can be found. On the setup page of the dialog, the data files used for registration can be selected in the file list, and the systems for which a transformation is computed can be selected using the checkboxes indicating the system number. Once the selections have been made, pressing the *Compute* button will start the coordinate system transformation computation.

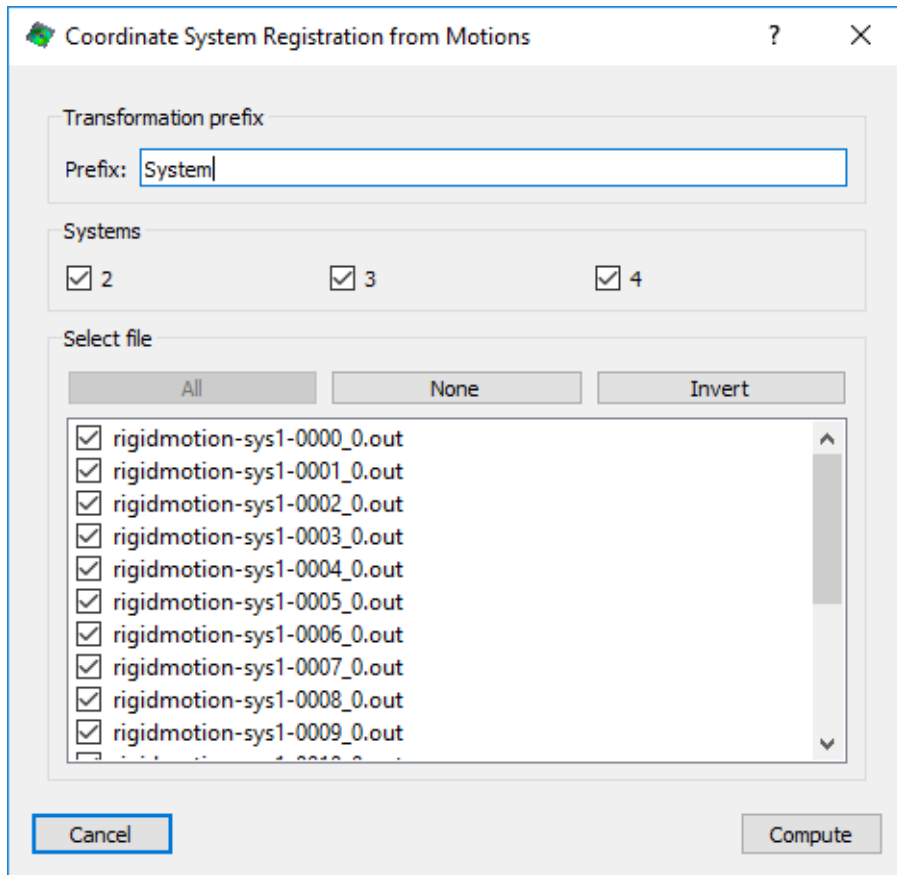

Figure 9.7: Multi-view registration dialog.

9.4.1.2 Checking Results

After the computation is complete, the dialog shows the computed transformations as well as the confidence intervals for all parameters in the log window. The results can also be visualized by clicking on the *Plot* tab as illustrated in Fig. 9.8. The drop-down menu in the top-right corner can be used to select which data file to display. The patches from all systems should appear in the correct relative orientations and rigidly move together when changing the data file.

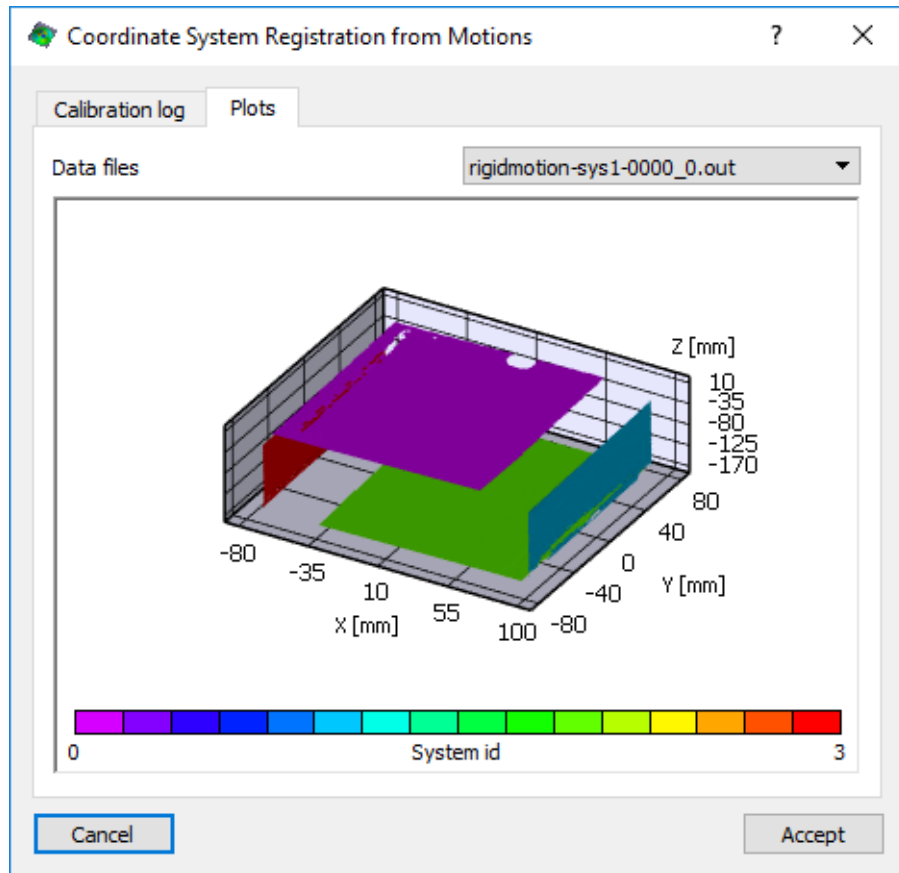

Figure 9.8: Multi-view registration results.

9.4.1.3 Generating Project Files

After the transformations have been computed in the Vic-3D project that belongs to the reference coordinate system, the project file must be stored. Then, for each of the N systems, the following steps have to be performed after opening the corresponding project file containing the calibration:

1. The menu entry *Data.. Coordinate Tools.. Set Coordinate System* can be used to set the correct transformation as the default coordinate system.
2. A prompt appears asking whether to import a transformation from a project file for all systems except the reference configuration. After accepting, the reference project file should be selected in the file dialog shown.

3. The correct transformation has to be selected from the list that appears, which is typically labeled **System N** unless the prefix was changed when computing the transformations.
4. The project file should be saved so it can be used as a template for analyzing the displacement data from the test article.

The project files created in this manner will contain the calibration for each system and the camera orientations are set such that the data will automatically be in the correct coordinate system when processing speckle images. There is no need for further coordinate transformations. For further details, see [Section 9.2.1](#).

9.4.1.4 Error Sources

If the coordinate systems are not registered correctly, there are a number of possible reasons that could be at fault.

- By far the most common mistake is to leave the auto-plane option enabled for analysis, see [Section 7.4.1](#) for details.
- Outliers or sparse data for one of the orientations can create large errors in the transformations. The input data for the computation should always be checked to ensure the correlation data is accurate.
- Insufficient rotations when acquiring the rigid body motion sequence can cause poorly estimated translation components in the coordinate system transformations. The image sequence should maximize rotation angles within the depth of field.

9.4.2 Registration from Overlap

To register two adjacent Vic-3D systems into a common coordinate system based on an overlapping region, the following steps are required (it is assumed that system 1 is the reference system):

1. A multi-system analysis in the overlapping region must be performed to obtain displacements from system 1 to system 2. Note that this only has to be done for a single image pair. See [Section 7.5](#) for details.
2. A rigid-body transformation is then computed from the displacements as described below in [Section 9.4.2.1](#).
3. The system 2 coordinate system is then set to this transformation to produce data in system 1's coordinate system. This step is analogous to the procedure described in [Section 9.4.1.3](#) above.

While this process seems straightforward, there are a number of pitfalls that should be avoided, particularly when registering a series of adjacent systems, e.g., a series of systems placed around the circumference of a cylinder. It is recommended to consider using the rigid motion based method described in [Section 9.4.1](#) above whenever practical as it is more accurate and more convenient. If this is not an option, however, the following suggestions might help:

- By far the most common mistake is to leave the auto-plane option enabled for analysis, see [Section 7.4.1](#) for details.

- The second most common mistake is to accidentally overwrite data files before computing the orientations. It is recommended to create a new directory for each analysis between neighboring systems and copy the required image and project files (with the calibrations for the relevant systems) into that folder. A convenient structure is

```
project/  
  registration/  
    sys1-sys2/  
    sys2-sys3/  
    ...  
    sysN-sys1/
```

Using this file structure avoids overwriting data files and ensures that errors can be traced back to where they occurred.

- Another possible error source is insufficient overlap between the adjacent systems. This can lead to high uncertainty in the computed transformations, and for a cylinder, might lead to a visible gap between the last and first system in the chain.

9.4.2.1 Computing a Rigid Transformation From Displacements

The menu entry *Data.. Coordinate tools.. Rigid transformation from displacements* displays a dialog that allows the computation of a rigid body transformation based on the displacements found in a data file. The dialog is shown in Fig. 9.9. The data file for which the transformation is computed can be selected from the drop-down menu in the top-right corner of the dialog. After pressing the *Calculate* button, the software displays the standard deviation of residuals as well as the rotation angles and translation vector components. After pressing the *Accept* button, the software prompts for a name to label the transformation. After entering a name, the transformation is stored in the project with the selected label.

9.4.3 Registration from Markers

In order to register coordinate systems with markers, the marker locations must be known in the desired coordinate system from a separate measurement. Once the marker locations are available in the target coordinate system, registration is straightforward:

1. The markers are first extracted in the marker editor (see [Chapter 15](#)) and labeled appropriately.
2. The marker coordinate system fit dialog is used to compute the transformation.

The most convenient method is to store the marker locations in a text file, which contains an entry for each label in the following format:

```
label,X,Y,Z
```

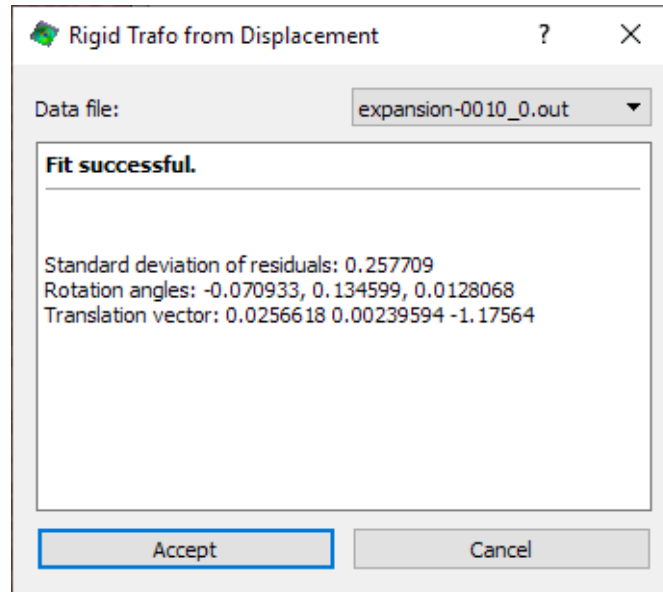

Figure 9.9: Rigid transformation from displacement.

If the markers are assigned corresponding labels when they are extracted in the marker editor, the registration can be performed with just a few mouse-clicks.

The marker coordinate system fit dialog can be shown by selecting the menu entry *Data.. Markers.. Coordinate system fit*. The dialog is shown in Fig. 9.10. The dialog has the following three group boxes.

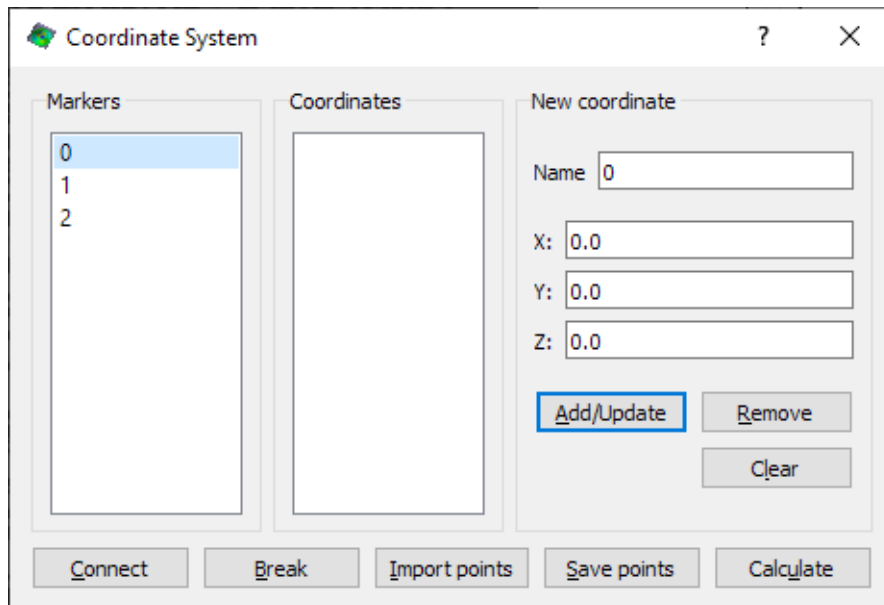

Figure 9.10: Coordinate system fit from marker locations.

Markers

Lists the markers by their labels.

Coordinates

Lists coordinates by their labels.

New coordinate

Contains editor fields to create new coordinates or delete existing coordinates. The following controls are available:

- *Name*: The name/label for the coordinate.
- *X/Y/Z*: The coordinates.
- *Add/Update*: Button to add a new coordinate or update the currently selected coordinate.
- *Remove*: Removes the current coordinate.
- *Clear*: Removes all coordinates.

For the coordinate fit to work properly, markers have to be connected to coordinates, i.e., the correspondence between markers and coordinates has to be explicitly defined. This is accomplished by selecting a marker and its corresponding coordinate and then pressing the *Connect* button. This has to be done for all marker/coordinate pairs that are participating in the coordinate system estimation. A connection between marker and coordinate can be broken by using the *Break* button. After a connection is broken, the marker will no longer be used in computing the transformation, unless it is connected again.

As previously mentioned, points can also be imported from a file. This can be accomplished by pressing the *Import points* button and selecting the file in the file dialog that appears. If the file contains coordinates with names matching the markers, the user is prompted whether to make automatic connections based on marker names.

The coordinates can also be saved using the *Save points* button. This will store the coordinates in a format that can later be used to re-import them.

Once at least three connections between markers and points have been made, the *Calculate* button can be used to compute the transformation. This will display a dialog showing the residuals of the fit and the triangulation errors as illustrated in Fig. 9.11. The transformation can then be assigned a label and stored in the project file.

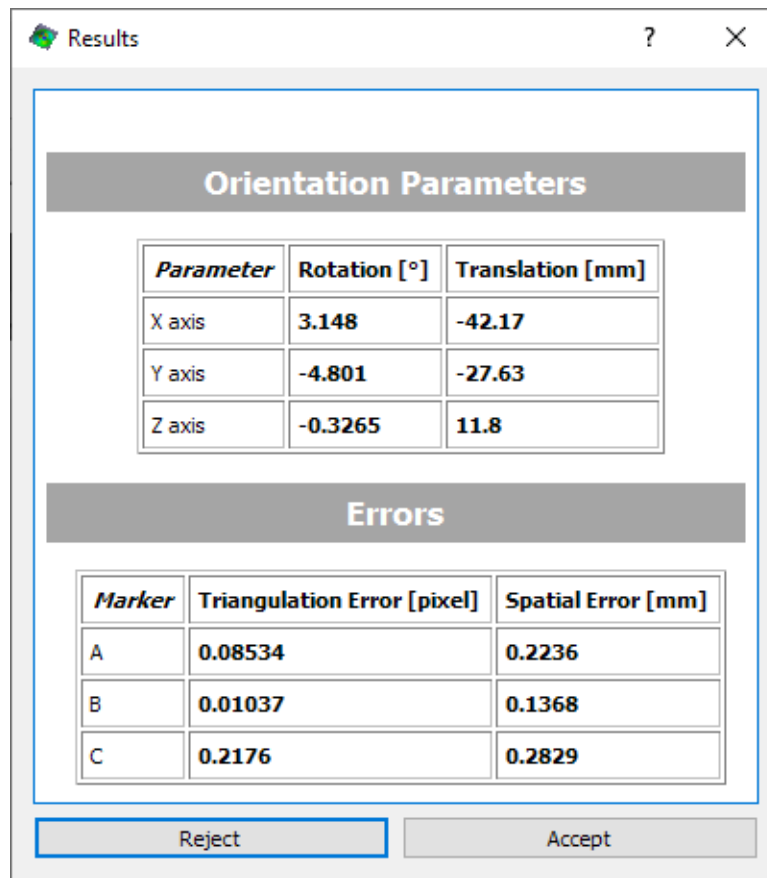

Figure 9.11: Result of coordinate system fit.

Chapter 10

Postprocessing Tools

Once the initial position and displacement fields are calculated, several tools are available for processing the data.

- **Calculate strain** - calculate surface strain tensors
- **Remove rigid motion** - removes overall object motion, leaving only deformation
- **Apply function** - apply arbitrary user-defined functions to create new variables
- **Restore data** - uses initial triangulation data to recreate original position and displacement field
- **Calculate velocity** - uses time information to calculate velocity and strain rate
- **Calculate curvature** - calculates local curvature over the surface
- **Calculate in-plane rotation** - calculates local surface rotation
- **Smooth** - smooths data over a user-specified diameter
- **Map external data** - map data from an external source such as an IR camera
- **Delete variables** - remove variables created with other postprocessing tools
- **Combine data files** - combine multiple data files for display as one
- **Apply math operation** - applies simple math operations to discrete variables

10.1 Strain Calculation

To calculate strain for one or more data sets, select *Data... Postprocessing options... Calculate strain* from the main menu. This will show the strain computation dialog as illustrated in Fig. 10.1. Note that strains may also be computed during the correlation analysis, see [Section 7.4.3](#) for details.

10.1.1 Selecting Data Files for Processing

The available data files are displayed in the *Data Files* list box. To select which files to process, click on the data file you want to select/deselect. This will toggle the check mark indicating whether the file is selected or not. For convenience, the buttons labeled *All* and *None* select/deselect all files, while *Invert* reverses your selection.

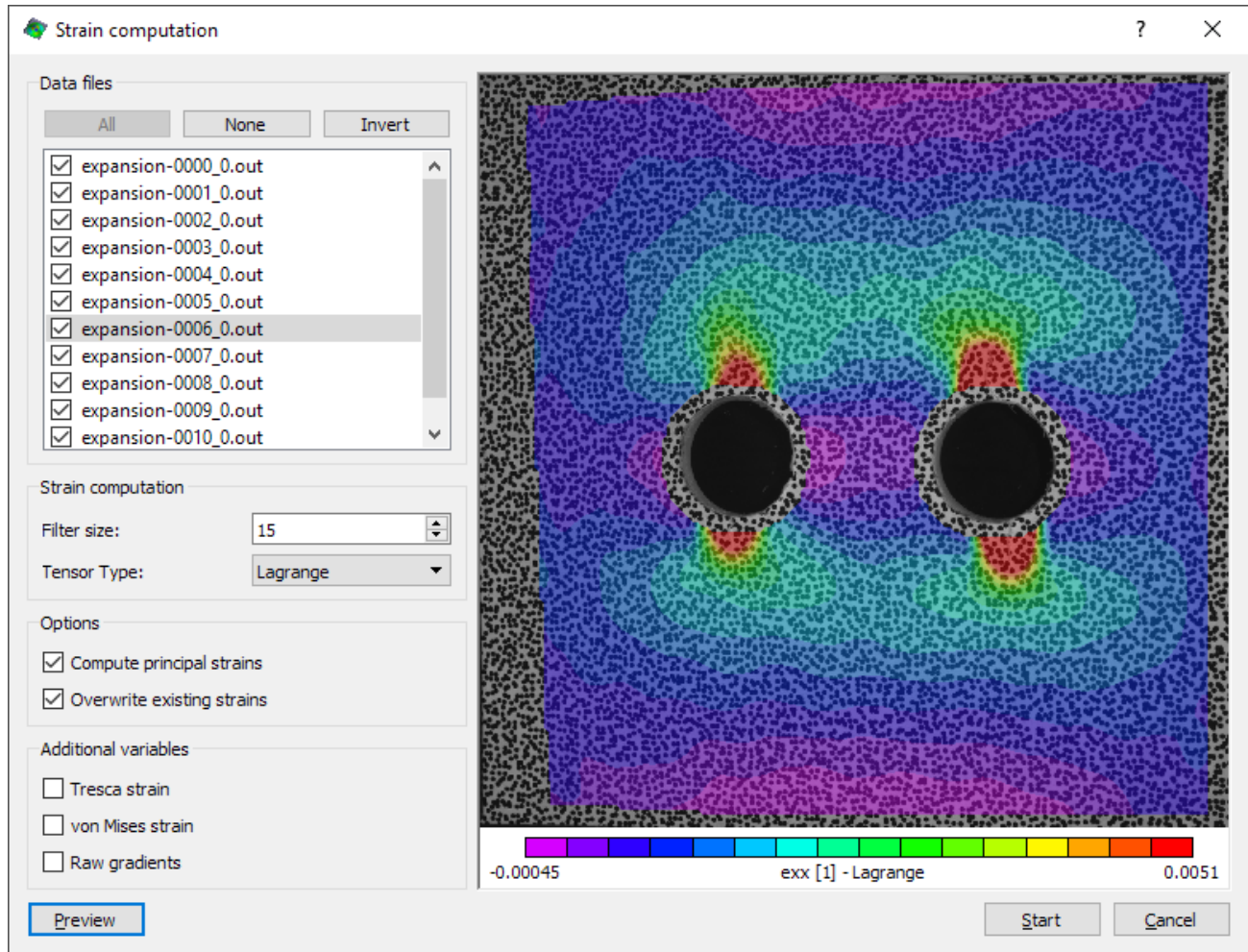

Figure 10.1: Strain dialog.

10.1.2 Preview

To view the effects of the calculation for a single data file, highlight the file and click the *Preview* button. You may view the plot in 2D or 3D (in Vic-3D) as with a standard data plot.

10.1.3 Compute Principal Strains

Check this box to add principal strains and principal strain angle to the calculated output data.

10.1.4 Overwrite Variables

Check this option to overwrite any existing strain calculations. If this box is clear, more data fields will be added to the output data set each time strain is calculated.

10.1.5 Compute Tresca/von Mises strain

Select these options to compute the Tresca/von Mises strain criterion along with the strain tensor calculation.

10.1.6 Filter size/type

Calculated strains are always smoothed using a local filter. The *Filter* box allows selection of a smoothing method. The decay filter is a 90% center-weighted Gaussian filter and works best for most situations; the box filter is a simple unweighted averaging filter.

The *Filter size* box controls the size of the smoothing window. Since the filter size is given in terms of data points rather than pixels, the physical size of the window on the object also depends on the [step size](#) used during correlation analysis.

10.1.7 Raw Gradients

This option can be used to output the components of the deformation gradient tensor \mathbf{F} . Note that the deformation gradient tensor is computed in the local tangential plane of the surface, and the x -direction is taken as the projection of the global x -coordinate onto this plane.

10.1.8 Tensor Type

Select the desired strain tensor. The default is Lagrangian finite strain. Note that in the case of Vic-3D, strains are computed in the local tangential plane of the surface, and the x -direction is taken as the projection of the global x -coordinate onto this plane. All strain tensors are derived from the deformation gradient tensor \mathbf{F} . Some of the definitions below use the Cauchy-Green deformation tensor

$$\mathbf{C} = \mathbf{F}^T \cdot \mathbf{F}$$

which is computed from the deformation gradient tensor \mathbf{F} .

Lagrange

This is the default strain tensor and is given by

$$\mathbf{E} = \frac{1}{2}(\mathbf{C} - \mathbf{I})$$

Hencky

The Hencky strain, also called logarithmic or true strain, is given by

$$\mathbf{E}_H = \frac{1}{2} \ln(\mathbf{C})$$

Euler-Almansi

The Euler-Almansi tensor is given by

$$\mathbf{e} = \frac{1}{2}(\mathbf{I} - \mathbf{F}^{-T} \cdot \mathbf{F}^{-1})$$

Logarithmic Euler-Almansi

The logarithmic Euler-Almansi strain is computed according to

$$\mathbf{e}_l = \frac{1}{2} \ln (\mathbf{F} \cdot \mathbf{F}^T)$$

Engineering

In order to avoid non-sensical strains due to rigid body rotations, the engineering strain is not computed directly from the derivatives of the displacement, i.e., $\epsilon_x \neq dU/dX$. To access the plain derivatives, see [Section 10.1.7](#) above. To make the strains insensitive to arbitrary rigid-body motion, the engineering strains are computed from the Lagrange strain tensor in the following manner:

$$\begin{aligned}\epsilon_x &= \sqrt{(1 + 2E_{xx})} - 1 \\ \epsilon_y &= \sqrt{(1 + 2E_{yy})} - 1 \\ \epsilon_{xy} &= \sin^{-1} \left(\frac{2E_{xy}}{\sqrt{(1+2E_{xx})(1+2E_{yy})}} \right)\end{aligned}$$

Biot

The Biot strain tensor is given by

$$\mathbf{E}_B = \mathbf{C}^{1/2}$$

10.2 Removing Rigid Motion

This tool is used to remove rigid-body displacement from deformed images, leaving only deformation components of displacement.

Once the displacement fields have been [calculated](#) from the speckle images, this tool can be started by selecting *Data... Remove displacements*.

10.2.1 Data File Selection

The available data files are displayed in the list box. To select which files to process, click on the data file you want to select/deselect. This will toggle the check mark indicating whether the file is selected or not. For convenience, the buttons labeled *All* and *None* select/deselect all files; the *Invert* button inverts the selection.

10.2.2 Processing method

To remove all rigid body displacement, select *Use average transformation*. This will calculate the average transformation for each image, and invert it to obtain an image with an average displacement/rotation of 0. Only object *deformation* will be reflected in the transformed U, V, and W displacements. This is useful for visualizing displacement fields in tests where deformation is obscured by larger, rigid-body motions.

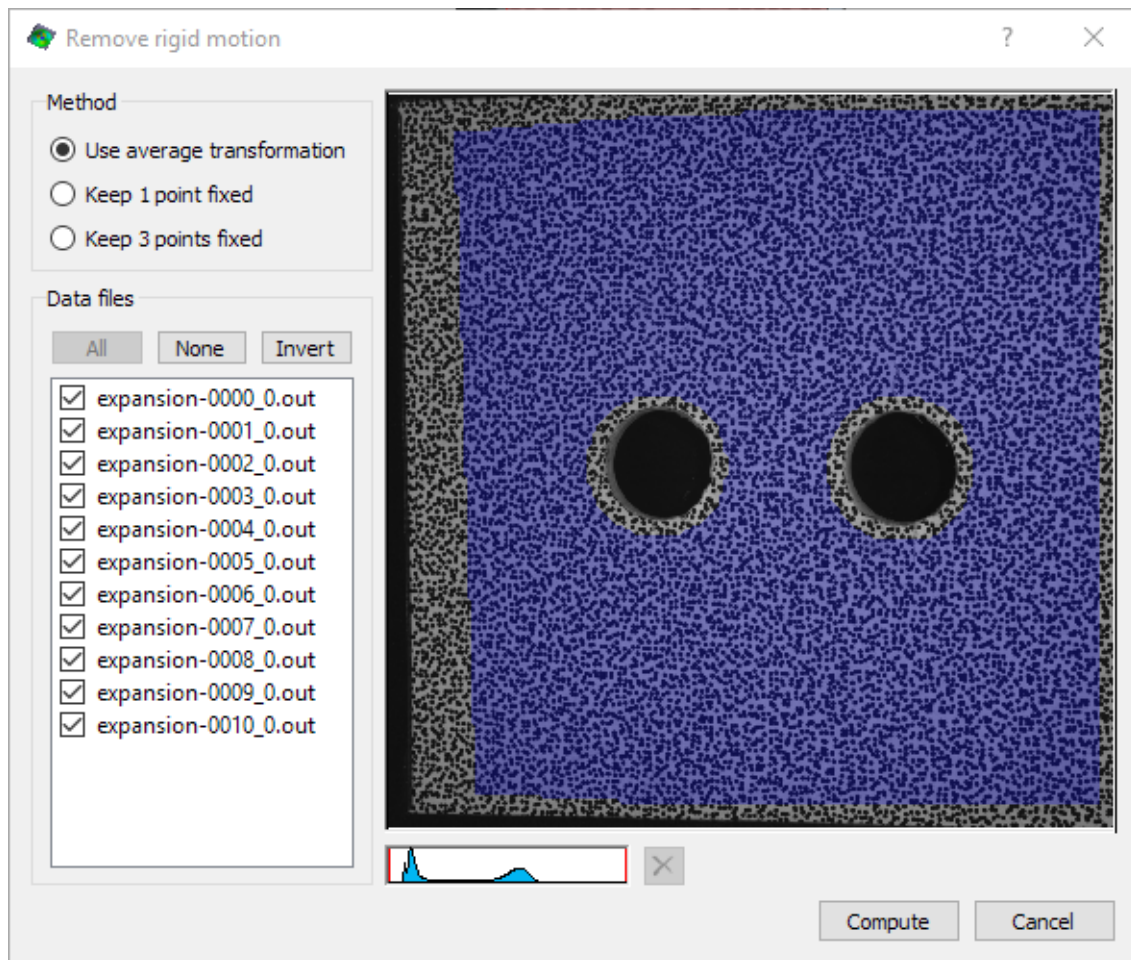

Figure 10.2: Rigid motion removal dialog.

To keep a single point stationary, select *Keep 1 point fixed* and click the desired point in the image. Only points within the data set (highlighted in blue) may be selected. With this method, the selected point will become stationary, with all other displacements remaining relative to this point. Any initial rotation will still be present after the operation.

To keep three points stationary, select *Keep 3 points fixed*; then, click three desired points in the image to define the fixed points. With this method, all displacements and rotations will be relative to the three selected points, which will become stationary. The point- and three-point displacement options are useful for, i.e., determining deformation of a test subject relative to fixed mounting points or standoffs.

If the three points you select are in three different AOI's, you will be given the option to use the entire AOI for the operation. This will be useful if, for example, you have small AOIs on top of three separate fixed posts of a test fixture.

Click *Compute* to proceed with the computation.



Strain Calculation

Note that these transformations will not affect calculated strain, nor are they necessary in order to correctly calculate strain; the strain algorithm is, by nature, insensitive to rigid-body displacements.

10.3 Applying Functions to Data

Vic-2D and Vic-3D support the generation of new variables based on equations applied to the data. This feature may be used, for instance, to compute engineering strains from Lagrange strains, to compute stresses from strains or to compute thinning of a strained specimen of known thickness based on the Poisson's effect or volume conservation during plastic deformation.

Functions may be created, modified, and applied to data by selecting *Data... Postprocessing options... Apply function* from the main menu.

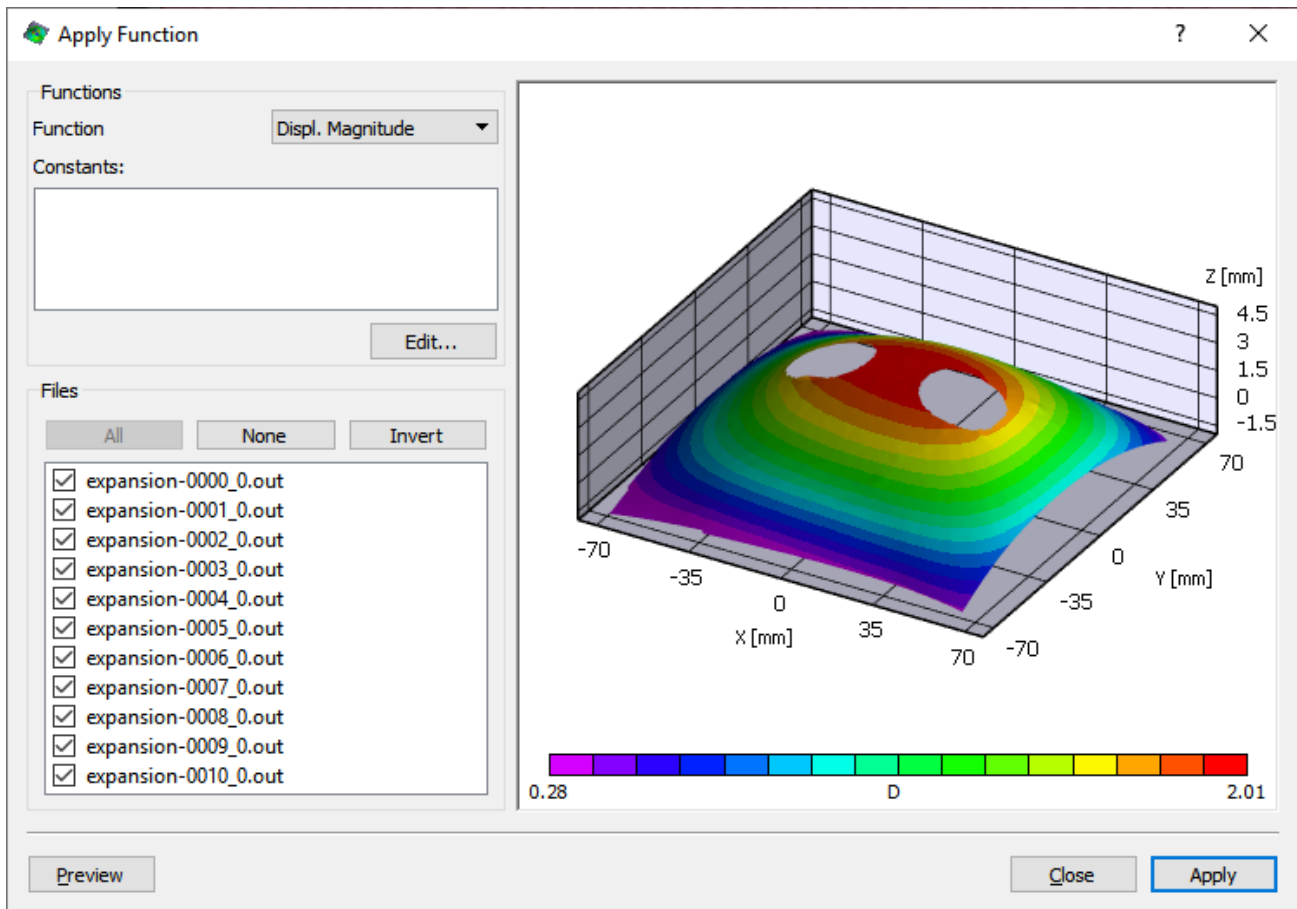

Figure 10.3: Apply function dialog.

A previously defined function may be selected from the *Function* pull-down menu in the upper left corner of the dialog. Each function may have one or more constants that are used in

its equations. When a function is selected, the corresponding constants are displayed next to their current values. Some constants may contain pre-defined options for the value. Selecting any of the options in the value combo-box will set the constant to that value.

10.3.1 Creating and Editing Functions and Constants

New functions and constants can be created and existing ones can be edited. Click on the **Edit...** button to open up the *Edit Functions* dialog.

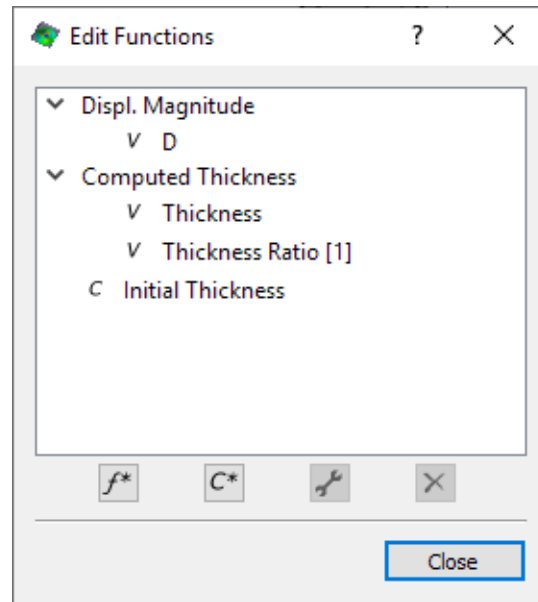



Figure 10.4: Edit functions dialog.

All available functions and constants are listed. Constants local to a function and the outputs of a function are listed underneath the function they belong to.

The four buttons underneath the list allow for the creation, editing and deletion of functions or constants. Each of the buttons are as follows:

- f^* Opens the wizard to create a [new function](#).
- C^* Opens the wizard to create a [new constant](#).
-  Opens a wizard to edit the selected [function](#) or [constant](#). If an output is selected it opens the function wizard to the edit outputs page.
-  Deletes the selected function or constant. If an output is selected it deletes the function it belongs to.

Double-clicking on any item in the list will open the respective wizard for editing.

10.3.2 Selecting Data Files for Processing

The available data files are displayed in the *Data Files* list box. Files to be processed can be selected in the list at the top left by checking or unchecking. There are also buttons to select and deselect all files and to invert the current selection.

10.3.3 Preview

The effects of the calculation on a single data file may be previewed by highlighting the file and clicking the *Preview* button. You may view the plot in 2D or 3D as with a standard data plot.

10.3.4 The Function Wizard

Functions and their output variables can be defined and edited in the function wizard. The wizard is a multi-page dialog that allows the user to enter all information required to define a function with one or more output variables.

10.3.4.1 Function Information

The first page of the function wizard is for entering a brief description of the function and the scope in which the function is stored. The *Global* scope option stores the function in the program settings where it can be used by any project. The *Project* stores the function in the project itself. If the project option is selected, then the function and its local constants are stored in the current project and is only accessible by the current project.

10.3.4.2 Define Equations

The next page is where the actual equations are entered. There can be multiple equations and they are separated by a new line; each should be in the form (variable)=(function definition). Double click on a variable at left to insert it at the cursor.

After you enter your equations and click *Finish*, any errors will be announced and corrections will be required before proceeding. For details on the equation syntax and built-in math functions, please refer to [Section 10.3.6](#).

10.3.4.3 Define Output Variables

Every function must have at least one output variable. The output variable is the information that is stored in the data files of the project. To add one, simply click *Add an output...* There are two things to be entered for each output. The first is the actual variable itself as used in equations. The second is a brief description of the variable - this will be displayed in plot context menus. The 'X' icon is the delete button. Clicking it will delete the associated output.

10.3.5 The Constant Wizard

Constants for use along with predefined values can be created and edited in the function wizard.

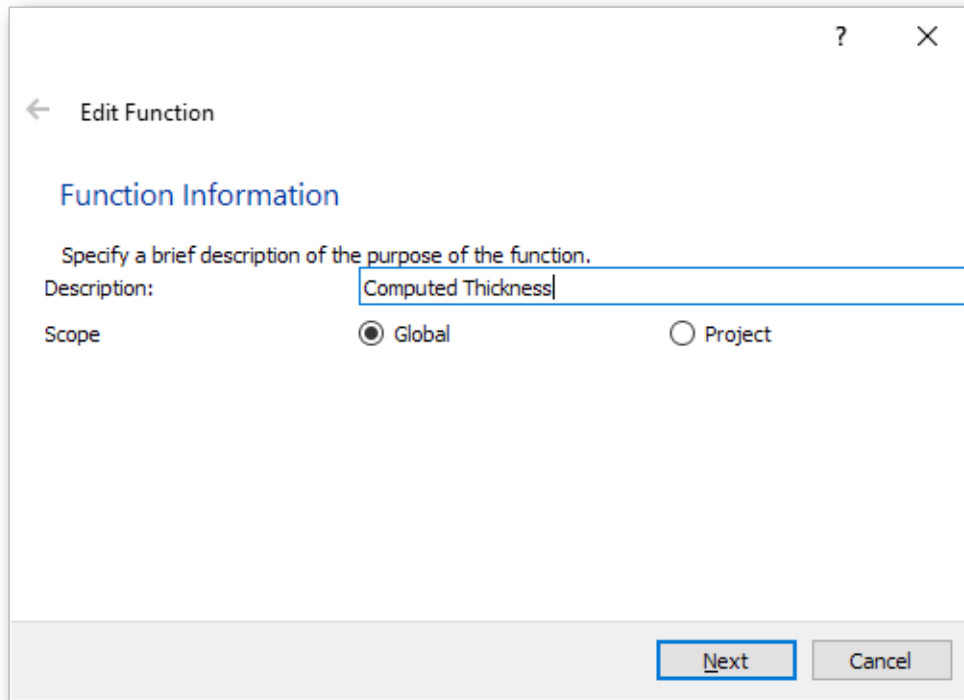

The image shows a software window titled "Edit Function" with a back arrow and a close button. The main heading is "Function Information". Below it, a prompt says "Specify a brief description of the purpose of the function." The "Description:" field contains the text "Computed Thickness". Under "Scope", the "Global" radio button is selected, and the "Project" radio button is unselected. At the bottom right, there are "Next" and "Cancel" buttons.

Figure 10.5: Function wizard information page.

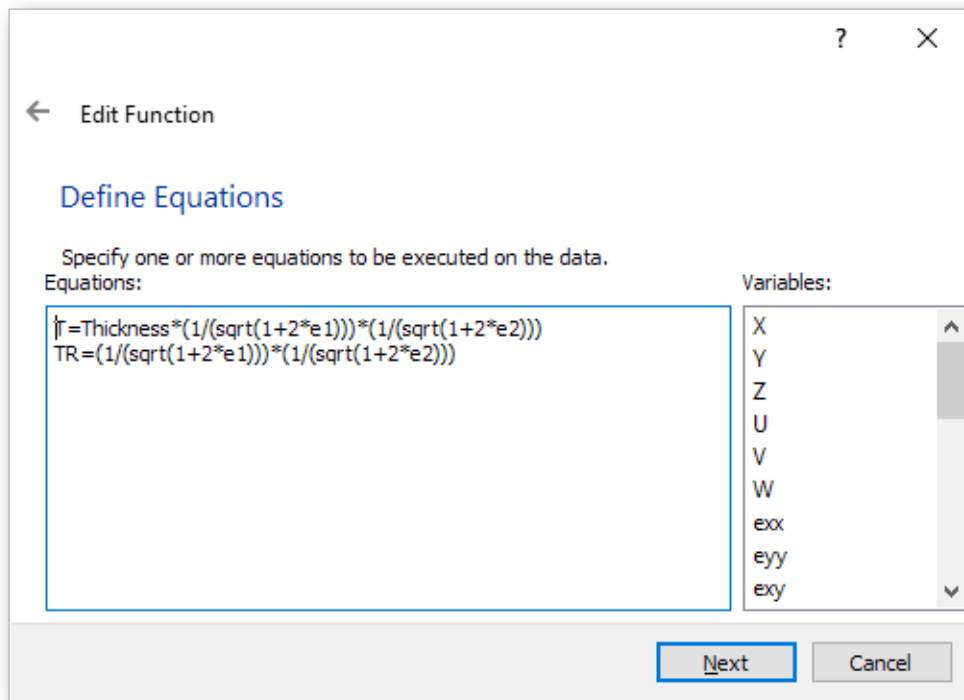

The image shows a software window titled "Edit Function" with a back arrow and a close button. The main heading is "Define Equations". Below it, a prompt says "Specify one or more equations to be executed on the data." The "Equations:" text box contains two lines of code:
$$r = \text{Thickness} * (1 / (\text{sqrt}(1 + 2 * e1))) * (1 / (\text{sqrt}(1 + 2 * e2)))$$
$$TR = (1 / (\text{sqrt}(1 + 2 * e1))) * (1 / (\text{sqrt}(1 + 2 * e2)))$$
To the right of the text box is a "Variables:" list box containing the following items: X, Y, Z, U, V, W, exx, eyy, and exy. At the bottom right, there are "Next" and "Cancel" buttons.

Figure 10.6: Function wizard equation page.

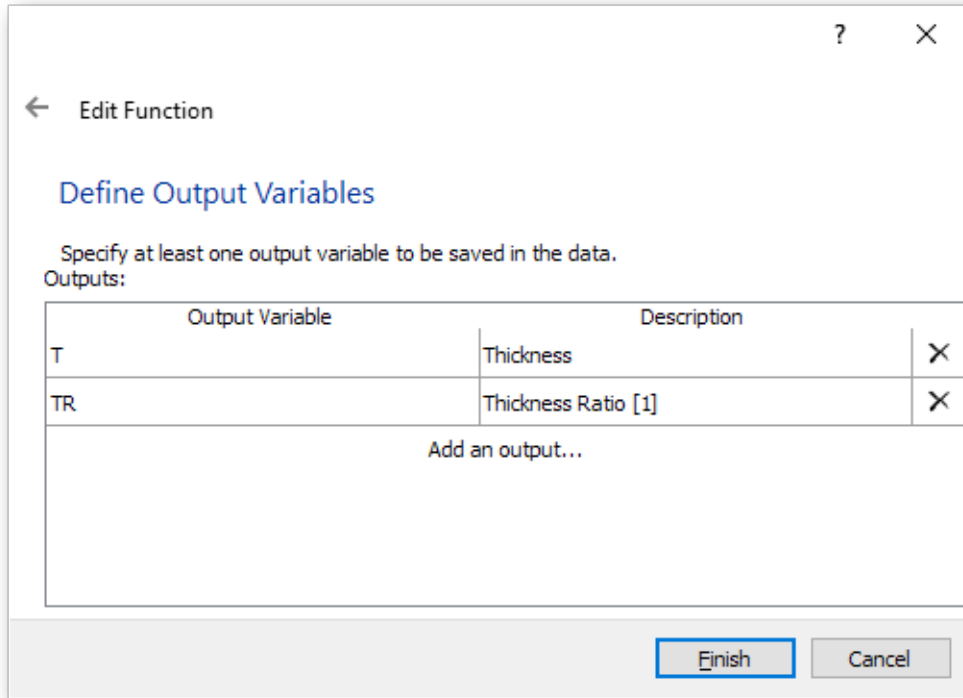

Figure 10.7: Function wizard outputs page.

10.3.5.1 Constant Information

The label defines what is to identify a given constant in an equation. The scope defines whether or not the constant is accessible to all functions (*Global*) or if it is only accessible to a specific function. The description is used to note the purpose of the constant.

10.3.5.2 Define Options

Defining options is not necessary but it can be helpful; for instance, a preselected group of material property constants, as in the example below. There are two values for each option: a description and a value.

10.3.6 Equation Format, Operators and Built-in Functions

The following table lists the functions that can be used in equations in Vic-2D and Vic-3D and the number of arguments they require.

Function name	Argument count	Explanation
sin	1	sine function
cos	1	cosine function
tan	1	tangens function
asin	1	arcus sine function

Function name	Argument count	Explanation
acos	1	arcus cosine function
atan	1	arcus tangens function
sinh	1	hyperbolic sine function
cosh	1	hyperbolic cosine
tanh	1	hyperbolic tangens function
asinh	1	hyperbolic arcus sine function
acosh	1	hyperbolic arcus cosine function
atanh	1	hyperbolic arcus tangens function
log2	1	logarithm to the base 2
log10	1	logarithm to the base 10
log	1	logarithm to the base 10
ln	1	natural logarithm to base e (2.71828...)
exp	1	e raised to the power of x
sqrt	1	square root of a value
sign	1	sign function -1 if x<0; 1 if x>0
rint	1	round to nearest integer
abs	1	absolute value
min	var.	min of all arguments
max	var.	max of all arguments
sum	var.	sum of all arguments
avg	var.	mean value of all arguments

The table below lists the binary operators available in Vic-2D and Vic-3D in order of priority (higher values mean higher priority).

Operator	Meaning	Priority
and	logical and	1
or	logical or	1
xor	logical xor	1
<=	less or equal	2
>=	greater or equal	2
!=	not equal	2
==	equal	2
>	greater than	2
<	less than	2
+	addition	3
-	subtraction	3
*	multiplication	4
/	division	4
^	raise x to the power of y	5

← Create EqConstant

Constant Information

Specify basic information about the constant.

Label:

Scope:

Description:

Figure 10.8: Constant wizard information page.

← Edit EqConstant

Define Options

Specify options.

Options:

Description	Value	
Titanium	1.1e+11	X
Copper	1.17e+11	X
Steel	2e+11	X
Aluminum	6.9e+10	X
Add an option...		

Figure 10.9: Constant wizard options page.

10.4 Restoring/Retriangulating Data

After data has been manipulated through math operations or postprocessing, it is possible to restore the initial position and displacement field without rerunning the correlation. To start, select *Restore data* from the postprocessing menu or toolbar.

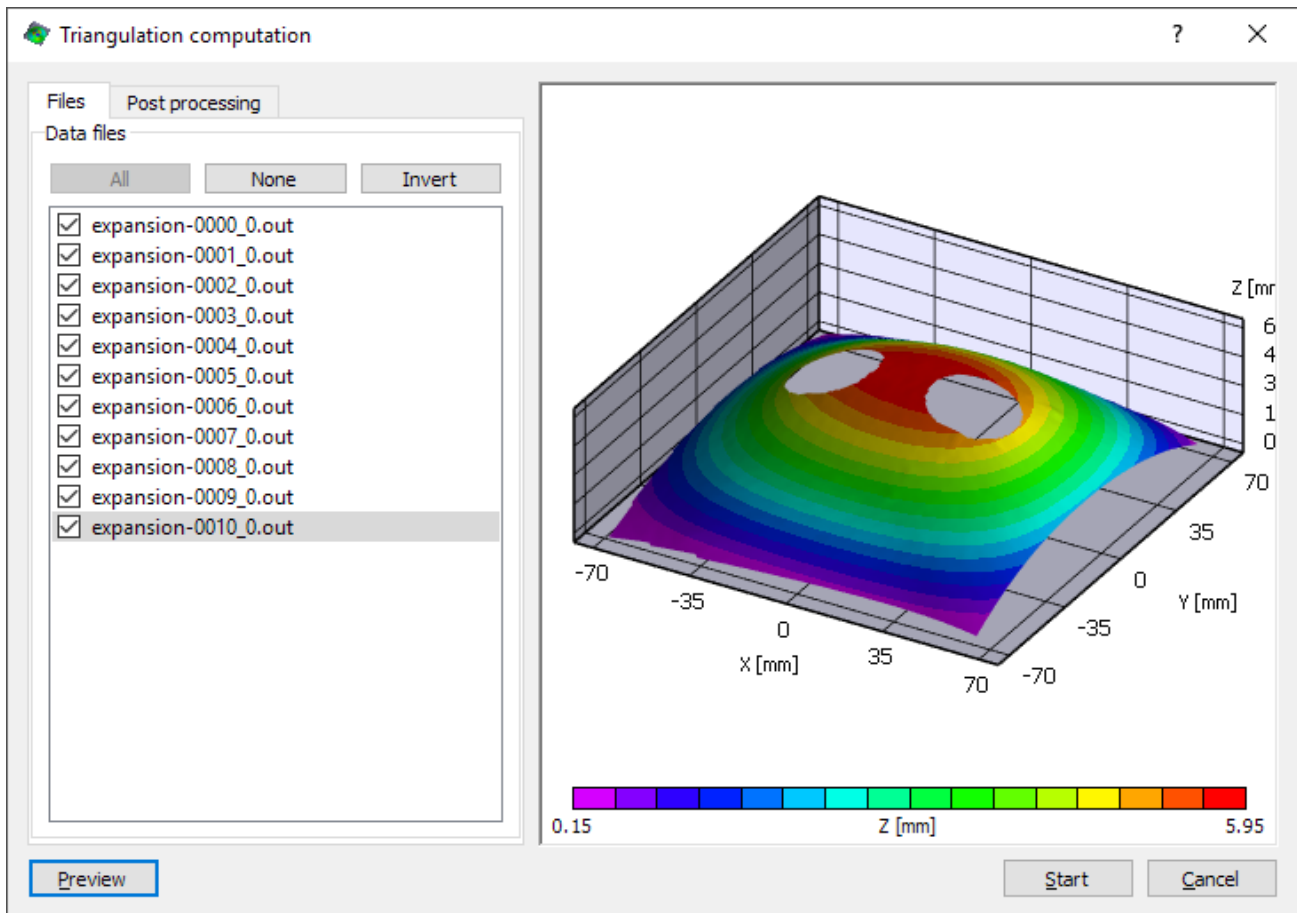

Figure 10.10: Triangulation dialog.

10.4.1 Data File Selection

The available data files are displayed in the list box. To select which files to process, click on the data file you want to select/deselect. This will toggle the check mark indicating whether the file is selected or not. For convenience, the buttons labeled *All* and *None* select/deselect all files; the *Invert* button inverts the selection.

10.4.2 Postprocessing

This tab contains the same postprocessing options as the initial Run dialog. Select the plane fit, confidence margin option, and strain calculation here.

To complete the operation, click **Start** to restore the data.

10.5 Calculating Velocity

Vic-2D and Vic-3D can calculate rates for displacement and strain, using either a specified time interval or time retrieved from a .CSV log file.

Once the displacement fields have been *calculated* from the speckle images, velocities may be calculated by selecting the *Calculate Velocity* entry on the *Data* menu. (If strain rates are desired, strain should be calculated before opening the *Calculate Velocity* dialog.) This will display the dialog shown in Fig. 10.11.

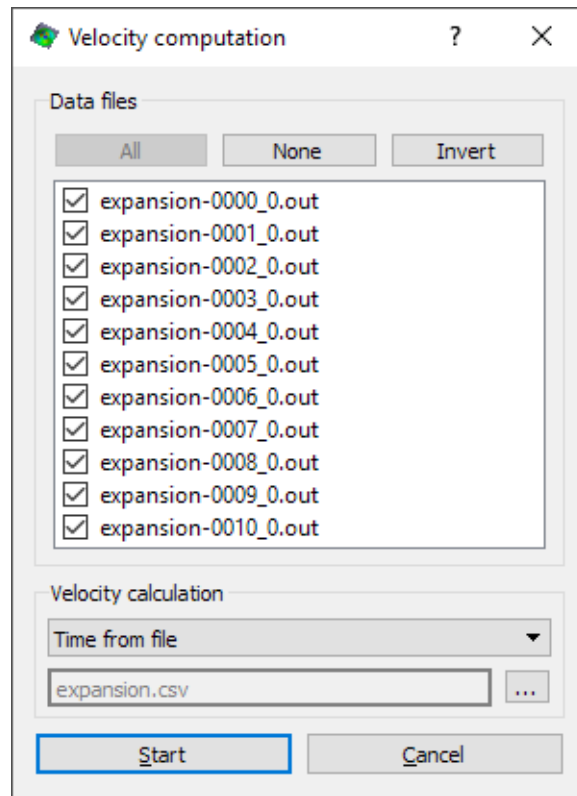

Figure 10.11: Velocity dialog.

10.5.1 Data File Selection

The available data files are displayed in the list box. To select which files to process, click on the data file you want to select/deselect. This will toggle the check mark indicating whether the file is selected or not. For convenience, the buttons labeled *All* and *None* select/deselect all files; the *Invert* button inverts the selection.

10.5.2 Velocity Calculation

If a Vic-Snap .CSV log file exists for the project, you may select “Time From File” from the dropdown and select the file, if necessary. Otherwise, select “Constant Time Step” and enter the

known time increment, or select “Constant Frame Rate” to enter a known frame rate, e.g., for data from a high-speed camera.

Click Start to begin; the progress bar will indicate completion. For each strain and displacement variable in the dataset, a derivative in time will be added and can be viewed as a [contour](#) overlay.

10.6 Curvature Calculation

To calculate local curvature for a set of data, select *Data... Postprocessing options... Calculate Curvature* from the main menu.

i Please note that this function returns values of $1/D$ and not $1/r$. This will result in a factor of 2 difference from the conventional measure.

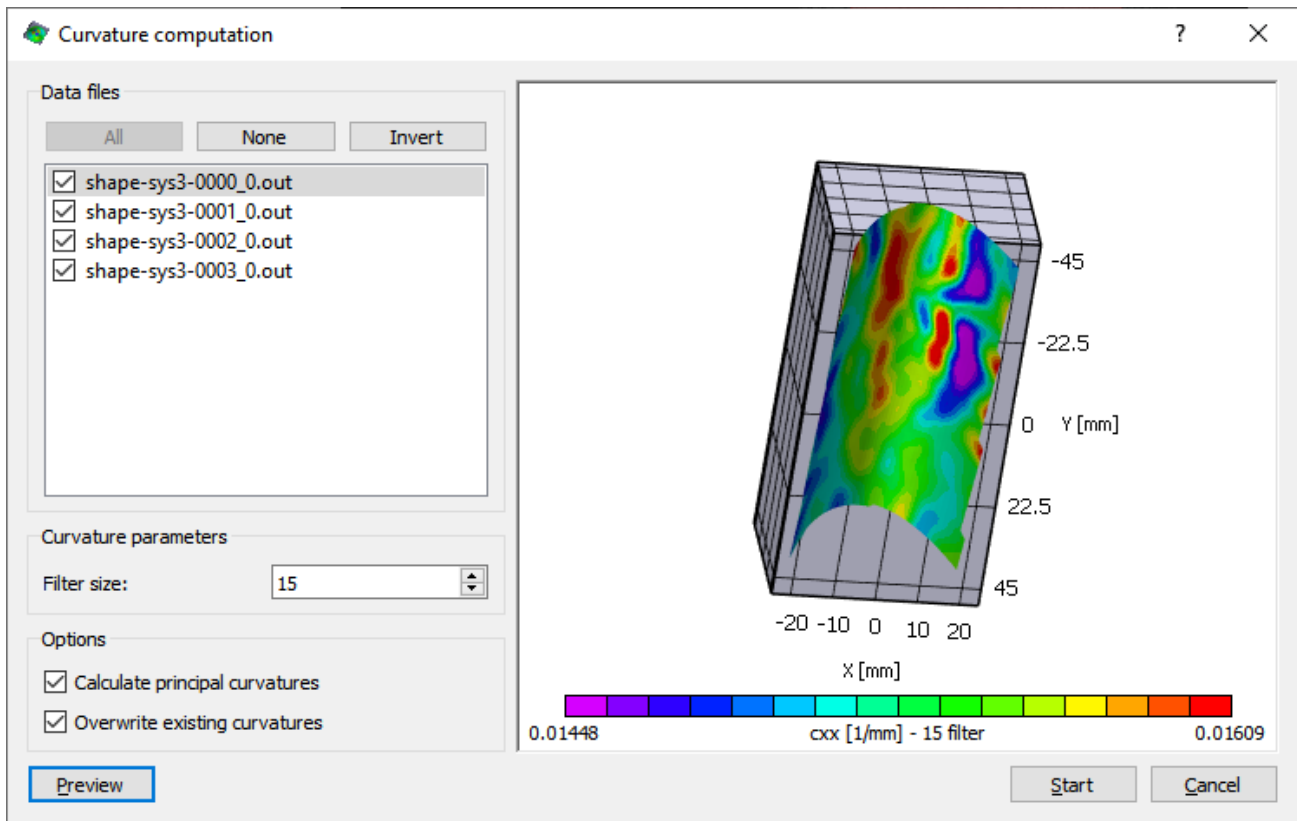

Figure 10.12: Curvature calculation dialog.

10.6.1 Selecting Data Files for Processing

The available data files are displayed in the *Data Files* list box. Files to be processed can be selected in the list at the top left by checking or unchecking. There are also buttons to select and deselect all files and to invert the current selection.

10.6.2 Preview

The effects of the calculation on a single data file may be previewed by highlighting the file and clicking the *Preview* button. You may view the plot in 2D or 3D as with a standard data plot.

10.6.3 Calculate Principal Curvatures

This box may be checked to add principal curvatures to the x/y curvature data.

10.6.4 Overwrite Variables

Checking this option will cause any existing curvature calculations to be overwritten. If this box is clear, more data fields will be added to the output data set each time curvature is calculated.

10.6.5 Filter Size/Type

The *Filter size* box controls the size of the smoothing window. Since the filter size is given in terms of data points rather than pixels, the physical size of the window on the object also depends on the [step size](#) used during correlation analysis.

10.7 Rotation Calculation

To calculate local in-plane rotation for a set of data, select *Data... Postprocessing options... Calculate in-plane rotation* from the main menu. This displays the dialog illustrated in Fig. 10.13.



This function computes the in-plane rotation around the local surface normal. To compute rigid-body rotation angles for the entire data set or selected areas (Vic-3D only), see [Section 12.7.1](#).

10.7.1 Selecting Data Files for Processing

The available data files are displayed in the *Data Files* list box. The files that will be processed are indicated with a check mark on the left. Selections can be made by clicking on the check boxes or by selecting one or multiple entries and pressing *Space* or *Enter*. The context menu provides further options for selecting a subset of data files. For convenience, the buttons labeled *All* and *None* select/deselect all files, while *Invert* reverses the current selection.

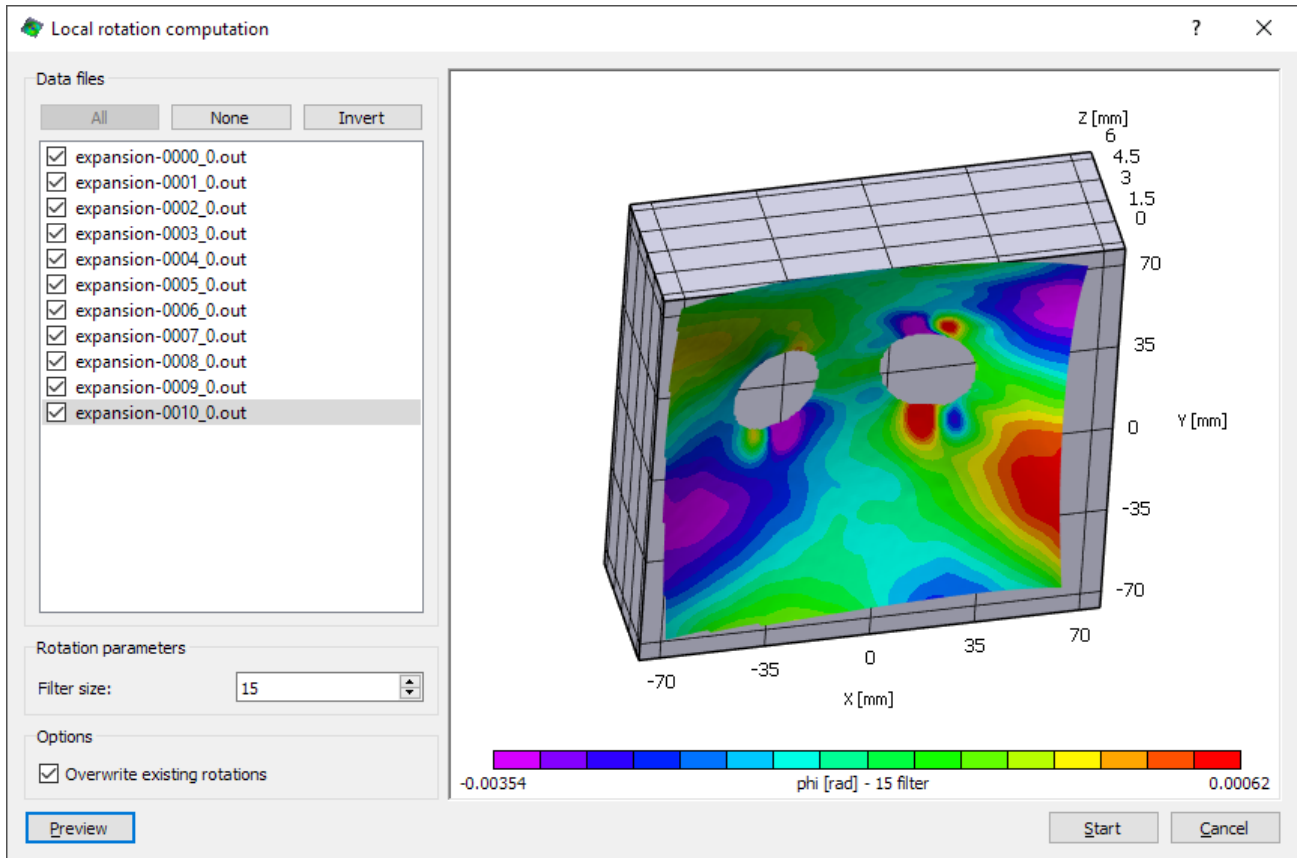

Figure 10.13: Rotation computation dialog.

10.7.2 Filter Size

The *Filter size* box controls the size of the window over which the rotation is computed. Note that a Gaussian weight function is applied to the window. Since the filter size is given in terms of data points rather than pixels, the physical size of the window on the object also depends on the *step size* used during correlation analysis.

10.7.3 Overwrite Variables

This box can be checked to overwrite any existing rotation variables from a previous computation. If this box is not checked, more data fields will be added to the output data set each time rotation is calculated.

10.7.4 Preview

To view the effects of the calculation for a single data file, highlight the file and click the *Preview* button. Note that the context menu of the plot can be used to switch between 2D and 3D plotting modes.

10.8 Smoothing Data

A smoothing filter may be applied to one or more data files by selecting *Data... Postprocessing options... Smooth variable* from the main menu.

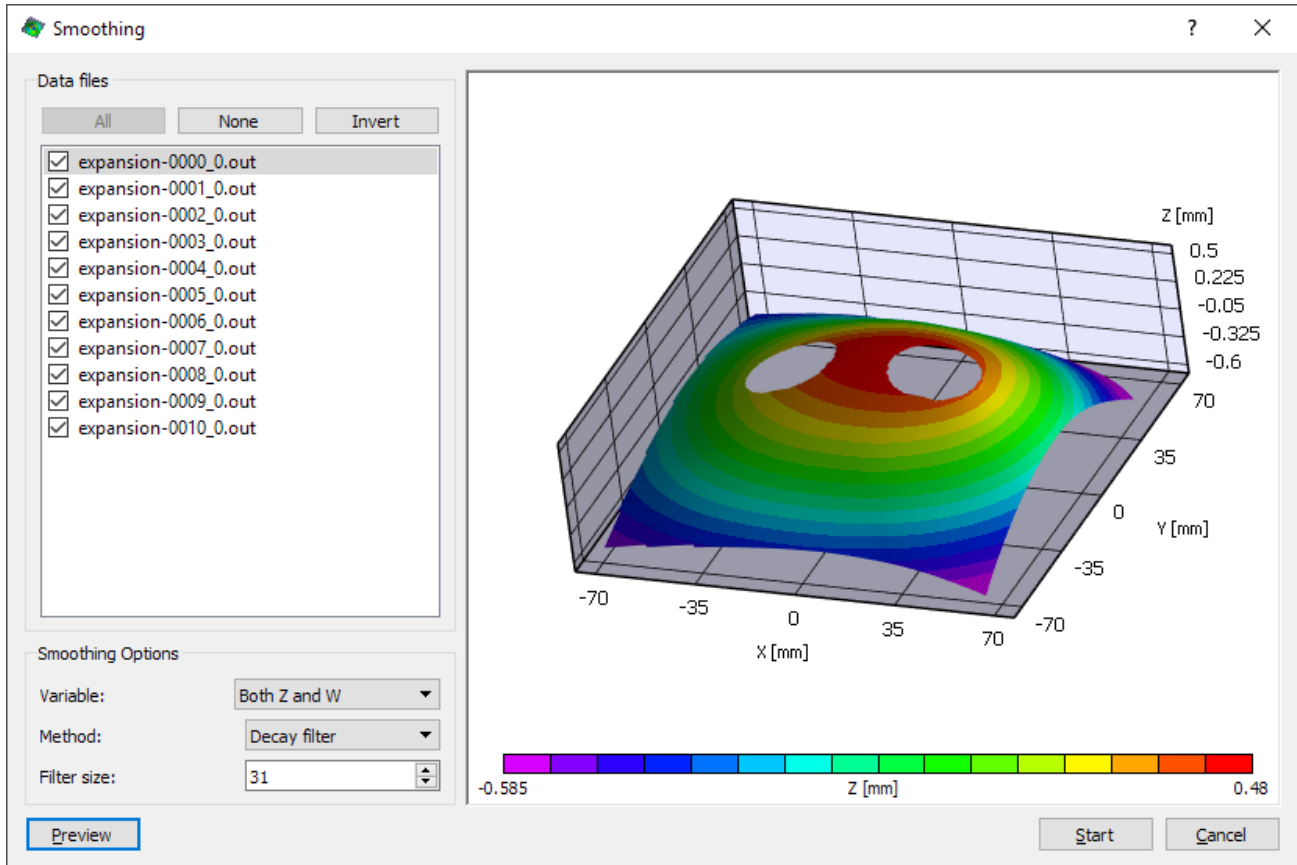

Figure 10.14: Smoothing dialog.

10.8.1 Selecting Data Files for Processing

The available data files are displayed in the *Data Files* list box. To select which files to process, click on the data file you want to select/deselect. This will toggle the check mark indicating whether the file is selected or not. For convenience, the buttons labeled *All* and *None* select/deselect all files, while *Invert* reverses your selection.

10.8.2 Preview

The effects of the calculation for a single data file may be displayed by highlighting the file and clicking the *Preview* button. The resulting plot may be viewed in 2D or 3D (for Vic-3D) as with a standard data plot.

10.8.3 Filter Size and Type

Data is smoothed using a local filter. The *Method* box allows selection of a smoothing method. The decay filter is a 90% center-weighted Gaussian filter and works best for most situations. The box filter is a simple unweighted averaging filter.

The *Filter size* box controls the size of the smoothing window. Since the filter size is given in terms of data points rather than pixels, the physical size of the window on the object also depends on the [step size](#) used during correlation analysis.



By default, 3D plots display deformed data - the sum of each point's X,Y,Z location and its U,V,W displacement. Because of this, creating a smooth plot of 3D data like the one above requires smoothing both Z and W.

10.9 Mapping External Data

The software supports mapping of externally acquired data from calibrated area sensors onto data files, e.g., to provide full-field temperature distribution data using infrared cameras. The mapping process requires a calibration for the external camera that is properly registered with the stereo system calibration. In order to ensure that the external camera is registered to the same coordinate system, at least one of the calibration target images must be acquired in the same orientation and chosen as the reference during the calibration process. See [camera calibration](#) for details.

To map externally acquired area data onto a data sequence, select *Data... Postprocessing options... Map external data* from the main menu or click  on the toolbar.

10.9.1 Automatic Operation

If IR images were acquired using Vic-Snap, images will be detected and the parameters set automatically. The last image will be previewed and you will be prompted to run the data.

10.9.2 Output Variable

Enter a unique label for the variable name, e.g., T for a temperature value, as well as a description of the variable, e.g., *Temperature [C]*.

10.9.3 Camera ID

Select the camera ID that you assigned during calibration of the external area sensor. If there is only one external camera, this should be Camera 2.

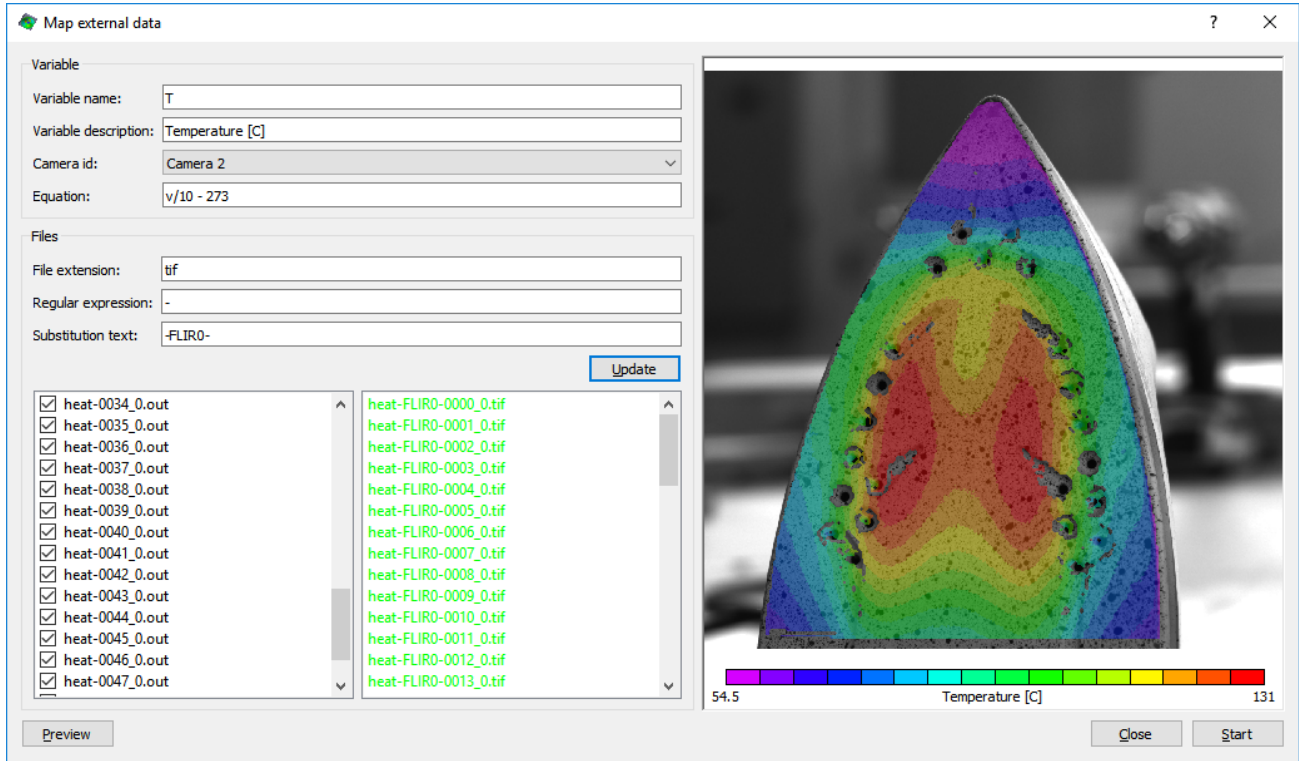

Figure 10.15: External data mapping dialog.

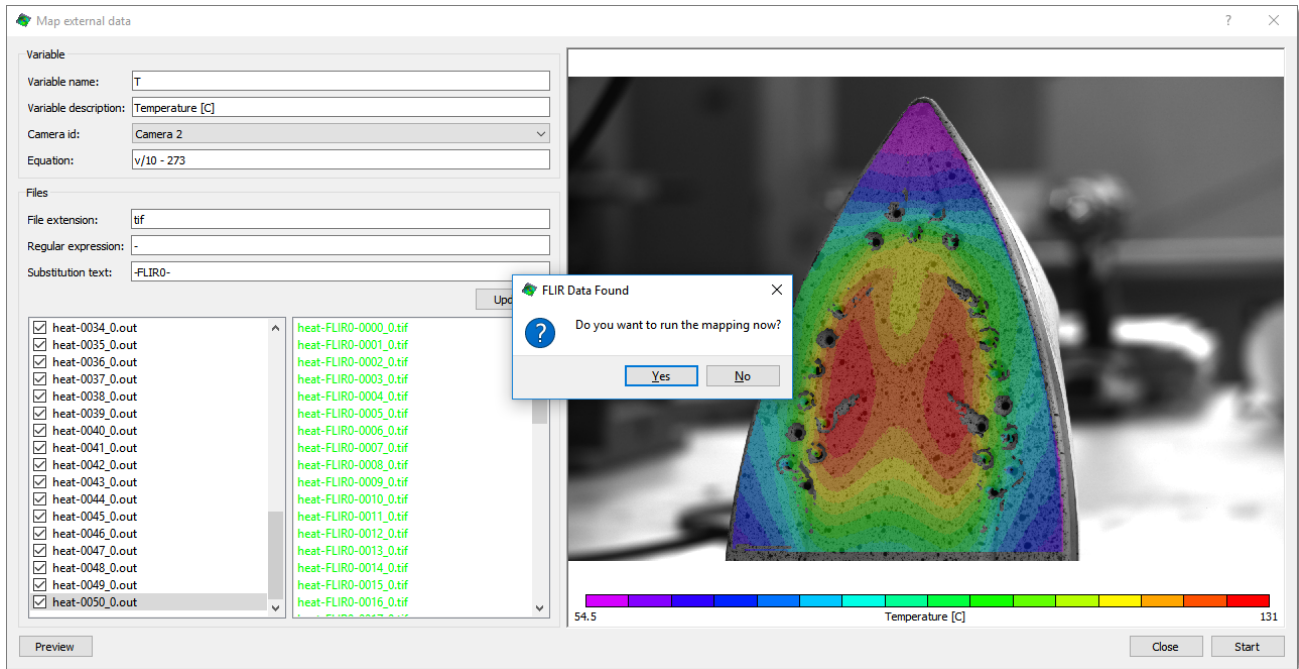

Figure 10.16: Automatic detection of IR data from Vic-Snap.

10.9.4 Equation

The values read from the data or image file acquired by the external sensor are passed through an equation. The value read from the data file can be accessed through the variable v in the equation. The default equation is simply v , i.e., the values read from the file are used unmodified. Aside from the value, the angle between the surface normal and the camera's optical axis can be accessed as θ , the location of the point can be accessed through the variables X , Y and Z , and finally, the distance of the point from the camera's pinhole point is available as D .

For details on the equation syntax and built-in math functions, please refer to [Section 10.3.6](#).

10.9.5 File Name Mapping

In order to locate the image or data file acquired by the external camera that corresponds to a given data file, you have to enter the file extension of the image/data files, and character substitutions if applicable.

Note: It is highly recommended to adopt a naming scheme for external data that is consistent with the Vic-3D file naming conventions. E.g., if the base name for the images is *tension*, the Vic-3D image files will be named *tension-xxx_0.tif* and *tension-xxx_1.tif* for the first and second camera, respectively. It is recommended to store the images from the external sensor as *tension-xxx_2.tif* or *tension-xxx_0.mat*, depending on the file format.

If the above recommendation is used, it is sufficient to enter the file extension preceded by the camera ID in the *File extension* field, e.g., *2.tif* or *2.mat*.

10.9.6 Regular Expression and Substitution Text

A regular expression can be used to match any part of the data file name with the purpose of substituting it. For example, if the data files from Vic-3D are named *tension-xxx_0.out* and the external data files are named *temperature-xxx_2.mat*, enter *tension* in the regular expression field and *temperature* in the substitution text field.

10.9.7 Update

The *Update* button can be used to verify that the files from the external sensor can be located properly. When the update button is clicked, the software will populate the list box to the right of the data file list box with the corresponding image file names from the external camera. Existing files will be shown in green, while missing files are shown in red.

10.9.8 Selecting Data Files for Processing

The available data files are displayed in the list box on the bottom left of the dialog. To select which files to process, click on the data file you want to select/deselect. This will toggle the check mark indicating whether the file is selected or not. For convenience, the buttons labeled *All* and *None* select/deselect all files, while *Invert* reverses your selection.

10.9.9 Preview

To view the effects of the calculation for a single data file, highlight the file and click the *Preview* button. You may view the plot in 2D or 3D as with a standard data plot.

10.10 Deleting Variables

User-generated variables can be deleted from data files.



Use this functionality with caution. Once removed, variables cannot be restored other than by reprocessing.

To remove variables from data files, select *Data... Postprocessing tools... Delete variables* from the main menu.

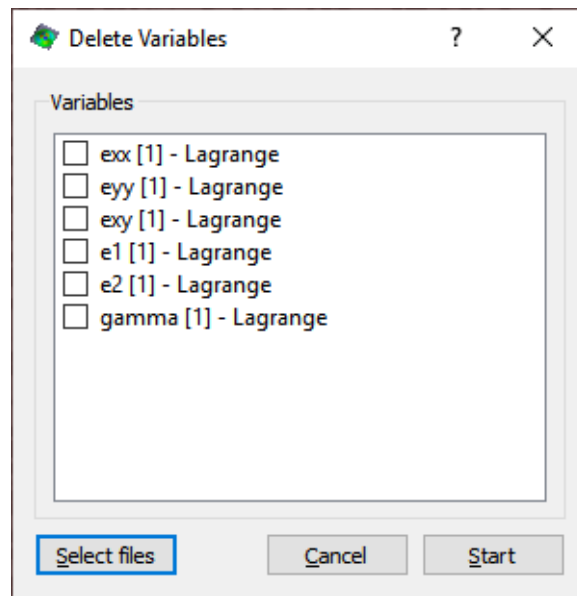

Figure 10.17: Delete variables dialog.

10.10.1 Selecting Data Files for Processing

Clicking **Select files** will bring up a standard file selection dialog, allowing the choice of some or all files to be processed.

10.10.2 Selecting Variables

The available variables are listed in the list box on the right of the dialog. Checking the box next to a variable will cause it to be deleted.

i Only user-generated variables such as strain, velocity, etc. may be deleted. Displacement, position, etc., may not be removed.

10.11 Time Filter

Time filters can be used to filter the full-field data along the time axis. Currently, filters for removing outliers and for smoothing are provided. The time filter dialog provides the ability to select multiple filters to create a filter chain. This can be used to, e.g., remove outliers and smooth data in a single pass. The time filter dialog is shown below.

To apply time filters to a data sequence, select *Data... Postprocessing options... Time filter* from the main menu.

i Placing an inspector point prior to opening the dialog will allow visualization of the filtering effect on the data.

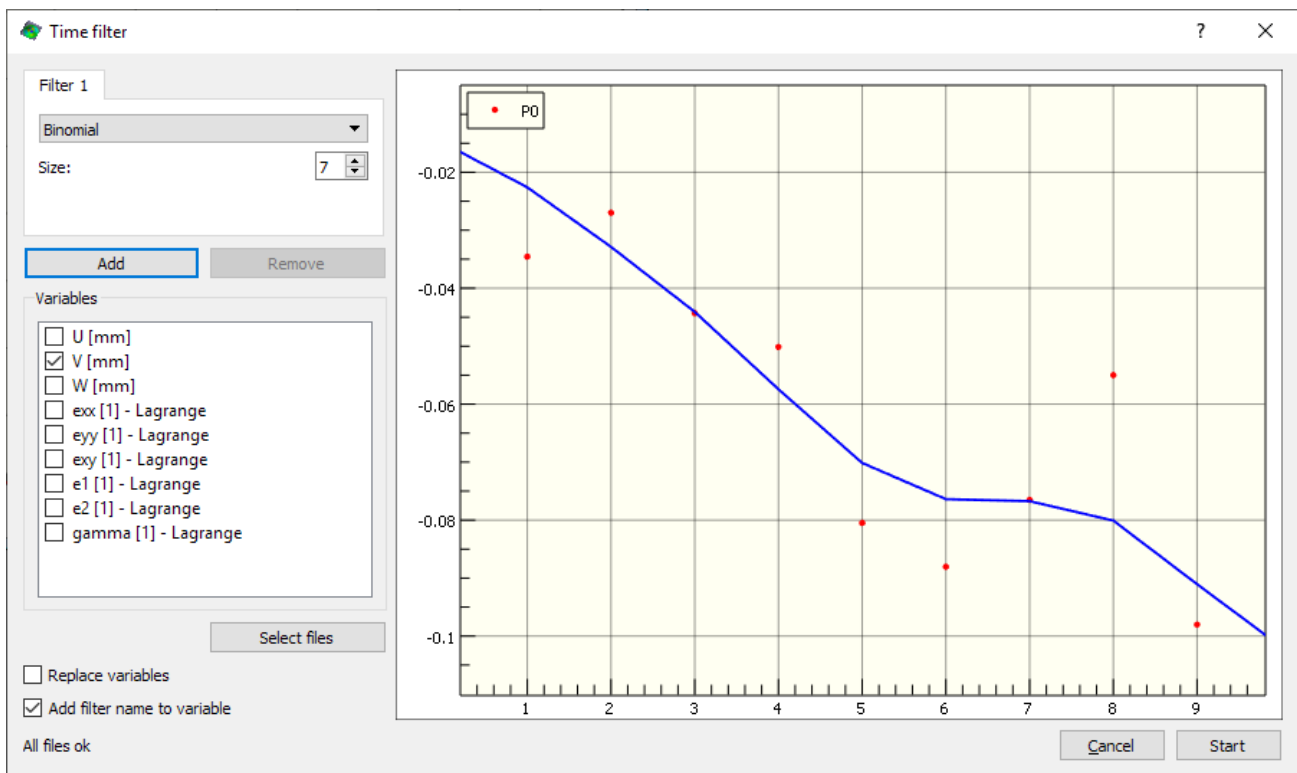

Figure 10.18: Time filter dialog

10.11.1 Validation

On startup, the time filter dialog validates the data files in the project. A progress bar in the bottom left corner indicates the progress of this operation. For projects with a large number of data files, this process may take some time to complete.

10.11.2 Preview

The time filter dialog can provide a preview that is updated in real time. This preview is available if inspector points, discs or rectangles have been added to any of the contour plots in the project. Note that the preview only becomes available after validation of the input files and after a variable for filtering has been selected.

10.11.3 Variables

In the variable box, one or more variables can be selected to which the filters are applied. The *Replace* variables check box can be used to overwrite the existing variables with the filtered results instead of creating new variables. The *Add filter names* to variables check box indicates whether the variable names of the filtered data should contain a description of the filter chain or not.

10.11.4 Filter Selection and Filter Chains

The type of filter to be applied can be selected in the drop-down box in the top-left corner of the dialog. By clicking the *Add* button, a second or third filter can be added to the filter chain. The *Remove* button can be used to remove an unwanted filter from the filter chain. Note that the filters are applied in the order they are added, as indicated by the number for the filter displayed on the tab bar.

10.11.5 Binomial Filter

The binomial filter is useful to apply moderate amounts of smoothing to the data. The binomial filter is a simple convolution filter. For a filter size of 3, the convolution mask is $1/4[1\ 2\ 1]$, and the larger filter masks can be obtained by repeated convolution of this mask with itself. The filter options for the binomial filter are shown below.

10.11.6 Median Filter

The median filter is useful for removing outliers from the data. The filter computes the median value in a neighborhood with user selectable size (see figure below). If the median filter is used in a filter chain, it should always be selected as the first filter so that outliers do not contribute to the results of the other smoothing operations.

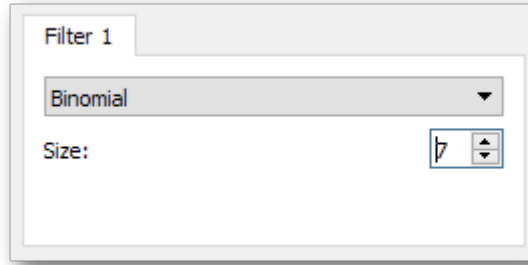

Figure 10.19: Binomial filter options.

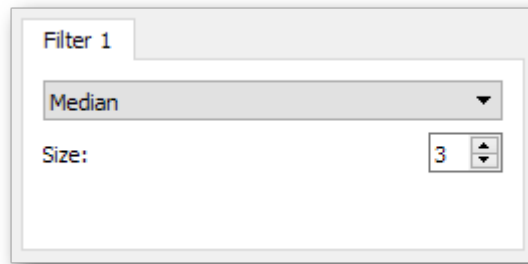

Figure 10.20: Median filter options

10.11.7 Recursive Low-Pass Filter

The recursive low-pass filter can be used to efficiently provide a large amount of smoothing. As illustrated below, the filter provides a user-selectable cut-off frequency and order. The cut-off frequency is the (normalized) frequency at which the transfer function has a value of 50%. The order determines the steepness of the fall-off. Note that for very low cut-off frequencies, this filter does not preserve the mean value of the data.

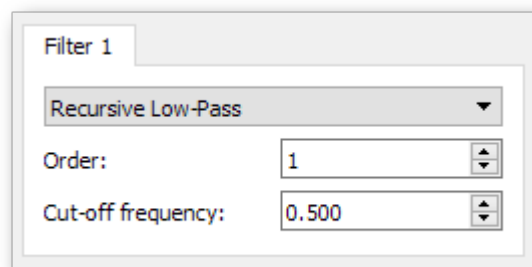

Figure 10.21: Recursive low-pass filter options.

10.11.8 Spline Fit Filter

The spline fit filter can be used to provide large amounts of smoothing. Depending on the order of the spline (linear, quadratic or cubic), this filter fits a curve consisting of multiple segments with c_0 , c_1 or c_2 -continuity between the segments. The lower the number of segments, the more smoothing is accomplished. Note that the number of segments must be lower than the number of data points. The options panel for the spline fit filter is shown below.

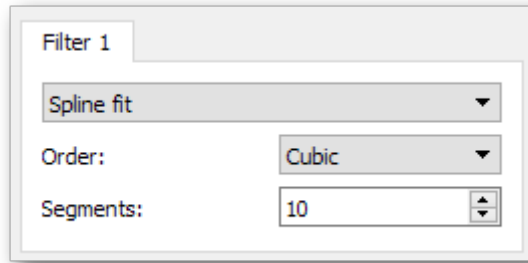

Figure 10.22: Spline fit filter options.

10.12 Time Averaging Data

The Time Averaging dialog is used for dealing with data which requires time averaging to eliminate certain biases or provide extra accuracy.

This functionality is designed to work with data which has been acquired in a specific way: for each specimen state, n image pairs should be acquired. For instance, 10 images taken at the reference state, 10 images taken at the first load step, etc. Next, the data including all images should be analyzed as usual. With the data below, we have taken 5 images at each of 8 load states, including the reference state.

Once the data is **calculated** from the speckle images, click *Data... Postprocessing tools... Time Average Data* on the main menu.

10.12.1 Options

If the **First group as reference** box is checked, the first set of data will be averaged to create a new reference configuration; then, this reference configuration will be subtracted from later groups, in effect re-referencing all of the data to a new, averaged meta-reference image.

The **Group size** indicates the number of images taken at each stage. Only divisors of the data file count may be selected so it is important that the correct number of input data files are present (an even multiple of n from above).

The new data files are prefixed with the selected **Output prefix**.

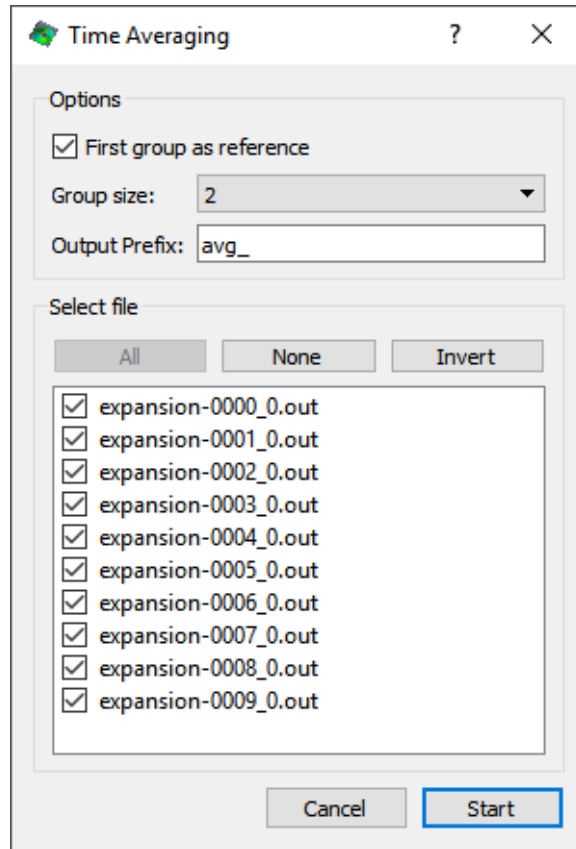

Figure 10.23: Time average dialog.

10.12.2 Selecting files

The available data files are displayed in the list box. To select which files to process, click on the data file you want to select/deselect. This will toggle the check mark indicating whether the file is selected or not. For convenience, the buttons labeled *All* and *None* select/deselect all files; the *Invert* button inverts the selection.

To begin the computation, click the **Start** button.

10.12.3 Results

Once the computation is finished, a new set of averaged data files will appear in the project panel under *Other data* as illustrated in Fig. 10.24. These data files contain the time averaged (and re-referenced, if selected) data. For plotting purposes, each averaged file is linked to a single input image so that 2D plots will display correctly.

10.12.4 Usage notes

The time average function can be used for any data that is noisy over time. Examples would include data which has pixel noise due to low light/high gain, as well as data which is corrupted by refractive heat waves. The specimen itself should be in exactly the same position for each

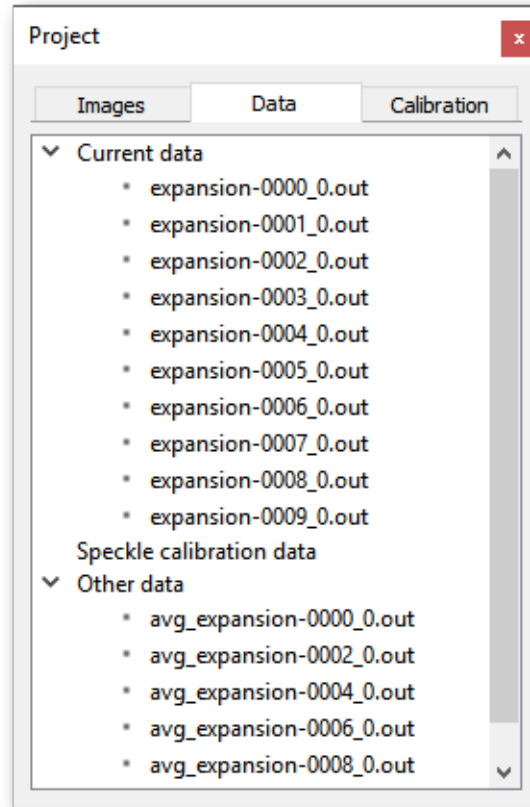

Figure 10.24: Project data panel showing time average data.

of the n images to avoid any bias; ideally, the only thing changing within an image set is the relevant noise.

10.13 Combining Data

Data files or groups of data files may be combined by selecting *Data... Postprocessing options... Combine data* from the main menu.

10.13.1 Selecting Data Files for Processing

The available data files are displayed in the *Data Files* list box. Files to be processed can be selected in the list at the top left by checking or unchecking. There are also buttons to select and deselect all files and to invert the current selection.

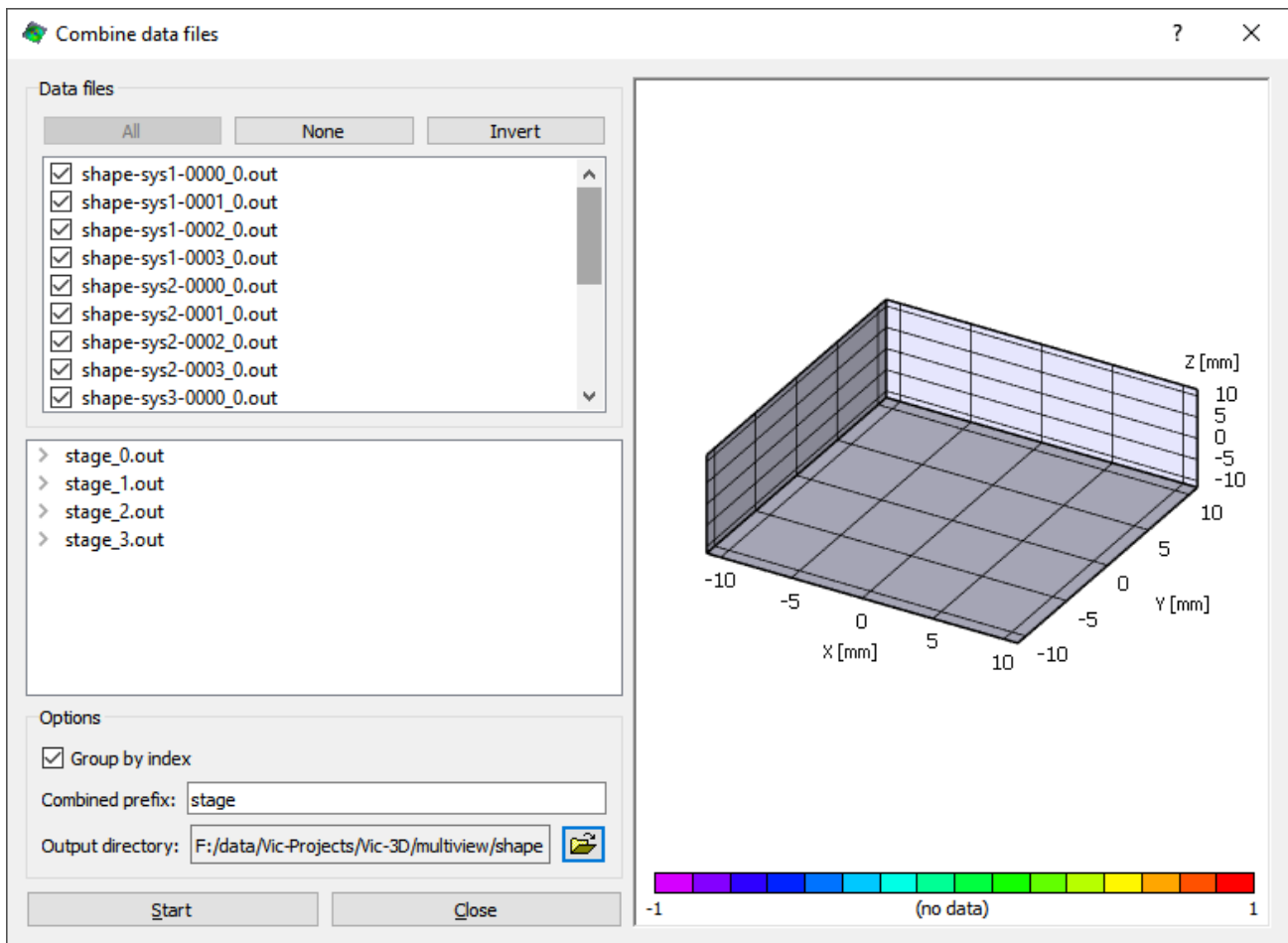

Figure 10.25: Combine data files dialog.



This dialog operates on all data files present in the project. Additional data files may be added prior to opening the dialog by selecting *Project... Data files* from the main menu.

10.13.2 Preview

An individual file may be viewed by clicking the file in the **Data files** list box. A combined set may be previewed by clicking the file in the tree view below that.

10.13.3 Options

The combine data dialog provides options that control how the data files are combined and how file names are generated for the combined data files. The options are found in the bottom left-hand corner of the dialog.

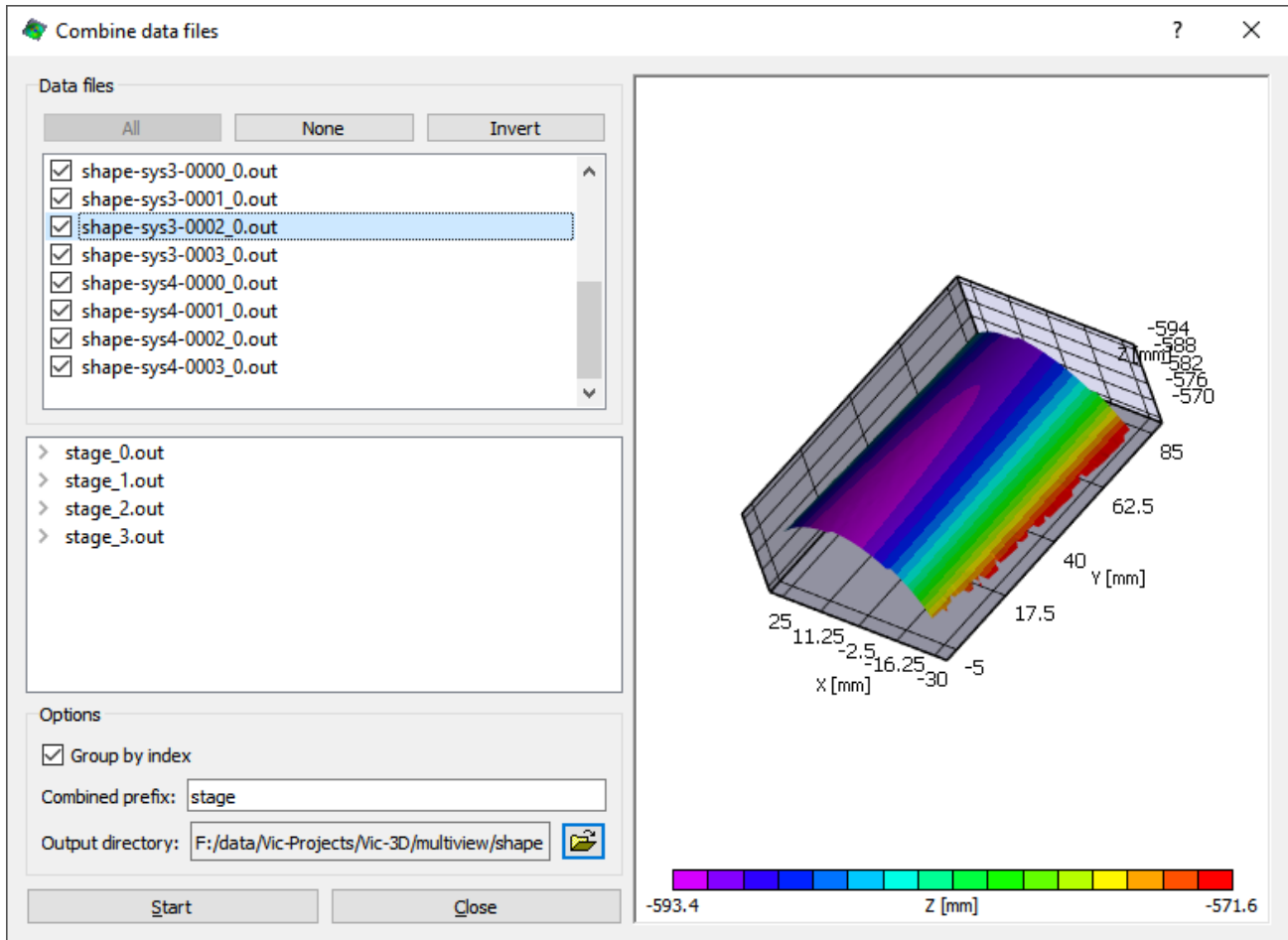

Figure 10.26: Combine data files preview.

Group by Index

By default, the files are grouped by index (sequence number). Clearing this check will cause **all** data to be combined into one file.

Combined prefix

This field controls the name of the new data files. When files are grouped by index, the sequence number will be added; otherwise, this will be the entire filename.

Output directory

The folder icon may be clicked to select a new output path for the files.

10.13.4 Combining Files

After files and options have been selected, the data can be combined by clicking the **Start** button. The files will be combined and added to the existing project file. The combined data files will be available in the *Other Data* section of the *Data* panel of the *project tool box*.

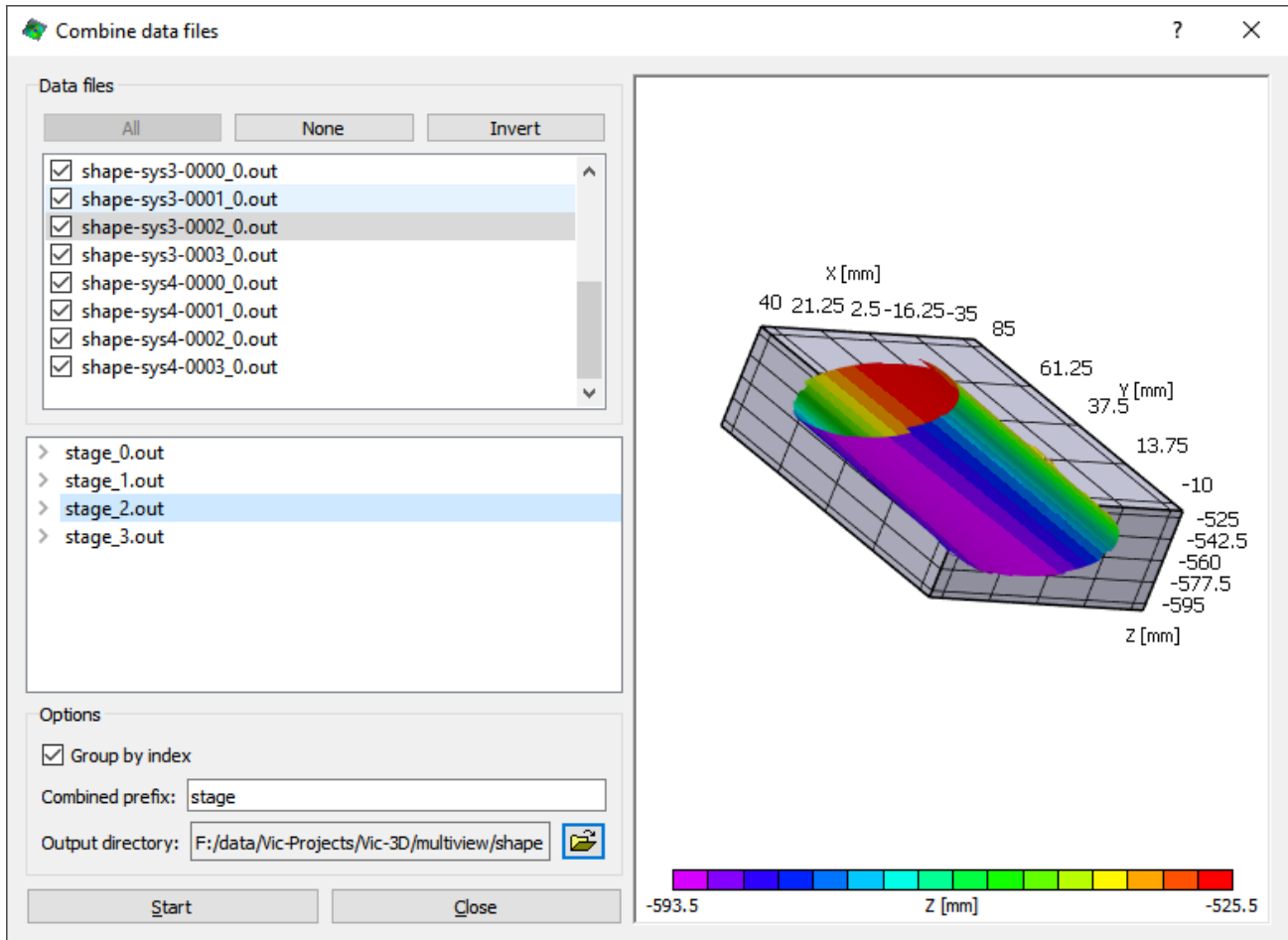

Figure 10.27: Showing combined data files.

10.14 Math Operations

The *Math operations* dialog allows manipulation of output data by basic math operations. The dialog can be opened by selecting *Data... Math Operations* from the main menu bar.



A much more powerful tool for applying general functions to data is available in the [Apply Function Dialog](#) and is generally recommended for math operations that operate on a single input data file.

10.14.1 Data File Selection

The available data files are displayed in the list box. To select which files to process, click on the data file you want to select/deselect. This will toggle the check mark indicating whether the file

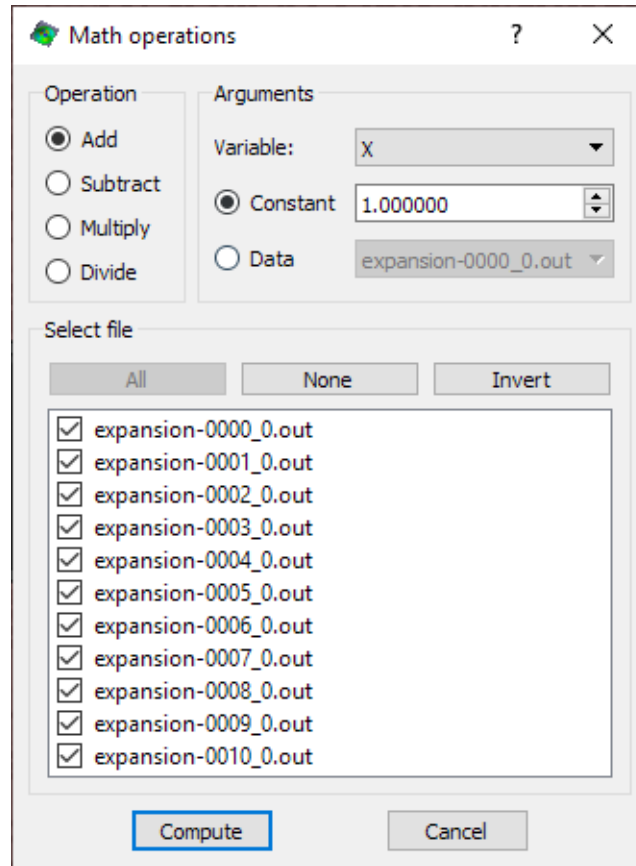

Figure 10.28: Math operations dialog.

is selected or not. For convenience, the buttons labeled *All* and *None* select/deselect all files; the *Invert* button inverts the selection.

10.14.2 Operation

Choose Add, Subtract, Multiply, or Divide to perform the specified operation.

10.14.3 Arguments

The *Variable* box is used to select the variable to operate on. Any variable in the data set may be selected.

To use a constant argument, select the *Constant* radio button and enter the value. For example, the selections below will multiply the W-displacement value from each data file by 10.

To use the data from an output file, click *Data* and select a data file. For example, the selections below will subtract the Z shape from the first data file, from all data files.

Click Start to begin; the progress bar will indicate completion. For each strain and displacement variable in the dataset, a derivative in time will be added and can be viewed as a [contour overlay](#).

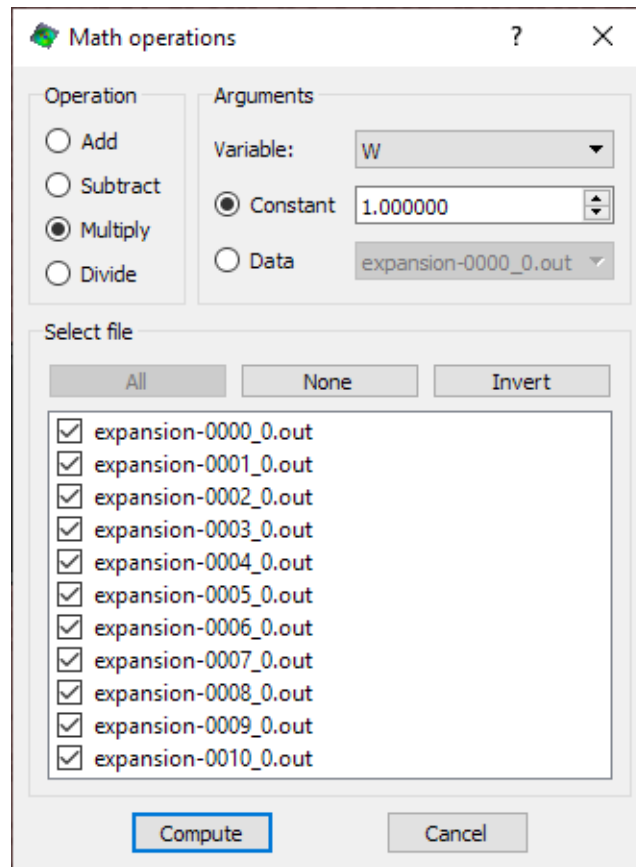

Figure 10.29: Math operation using a constant input.

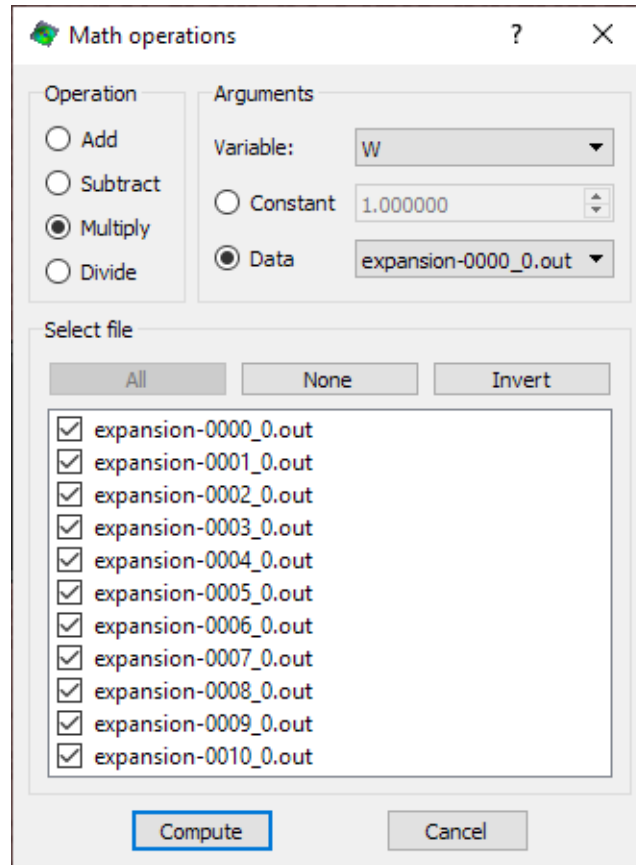

Figure 10.30: Math operation using a data file as input.

Chapter 11

Exporting Data

Calculated position and displacement data, along with transformed and post-processed variables, can be exported via several different options:

- **All data** - export entire data set
- **Pixel grid data** - sample data set on a pixel grid
- **Metric node data** - place surface nodes using metric coordinates, e.g., for FE comparisons
- **Aggregate statistics** - export mean, median, deviation, min, max for selected files and variables

i When viewing exported data, keep in mind that X, Y, and Z are the *reference* position of each point. In Vic-3D, these values are displayed as changing through time for visualization, but in exported data, these values will be *constant* through time.

11.1 Exporting All Data

For efficient file access, data is stored in a binary file format. To use the data with other programs for post-processing and plotting, the data can be exported by selecting the *Export* item from the *Data* menu or using the keyboard shortcut CTRL+E. The dialog shown in Fig. 11.1 will appear.

11.1.1 Selecting Files for Exporting

The available data files are displayed in the list box. To select which files to export, click on the data file you want to select/deselect. This will toggle the check mark indicating whether the file is selected or not. For convenience, the buttons labeled *All* and *None* select/deselect all files.

11.1.2 File Formats

The data files can be exported to the following formats:

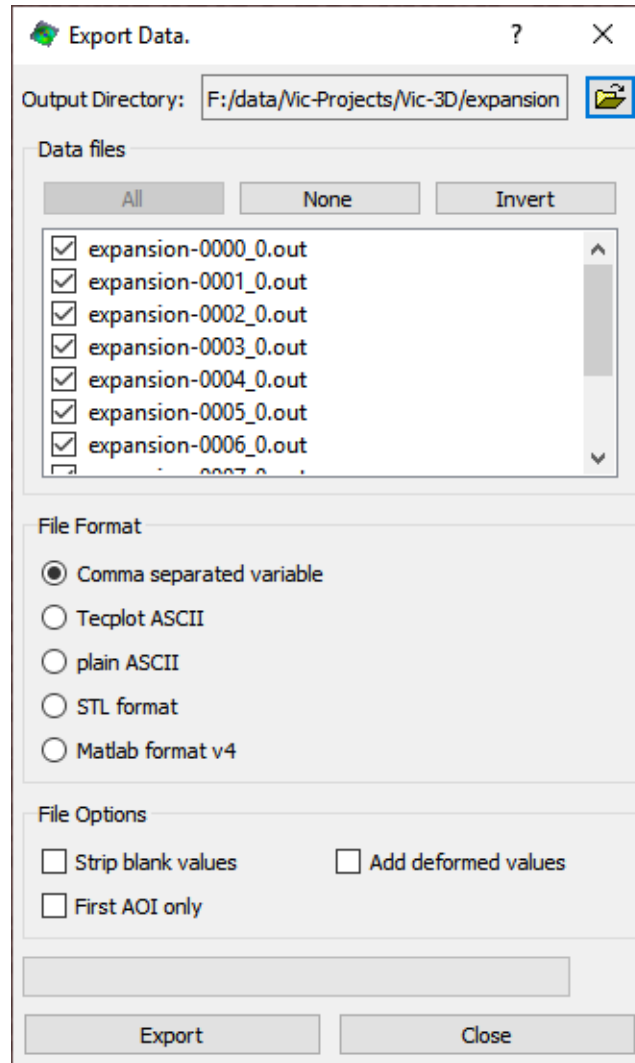

Figure 11.1: Export data dialog.

Comma-Separated Variable

Data entries are separated by commas. This format is understood by most spreadsheet programs and plotting packages. Variable names are stored in the data file as comma-separated strings in quotation marks. Exported files will have the extension *csv*.

Tecplot

Used for plotting the data with *Amtec's* (www.amtec.com) plotting program *Tecplot(TM)*. Exported files will have the extension *dat*.

Plain ASCII

This format is plain, space-delimited ASCII text data with one data point per line. Note: There are no variable names in the data file, and data from different AOIs is concatenated. Exported files will have the extension *txt*.

STL Format

This format provides a triangulated surface compatible with many CAD programs.

Matlab V4

This format provides compatibility with Matlab and many other programs capable of reading Matlab files. Note that if multiple AOIs are present in a datafile, unique names for each of the matrices are generated by appending increasing numbers to the variable names. For instance, the X-coordinate for the first AOI will appear as X in the matlab file, and for the second AOI it will appear as X_0 and so forth.

i If none of the available file formats fit your needs, please contact support@correlatedsolutions.com. We will gladly implement data exporting to a format that best suits your needs.

11.2 Exporting Grid-Based Data

This option can be used to export your data, sampled at regular intervals spatially (in the image domain) and for each data file, to a single text file. To begin, select *Export Grid Data* from the *Data* menu.

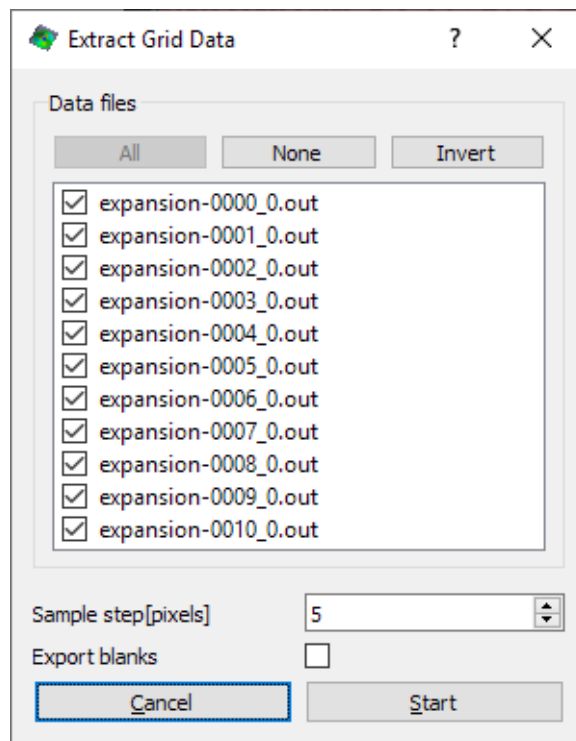

Figure 11.2: Extract grid data dialog.

11.2.1 Data File Selection

The available data files are displayed in the list box. To select which files to process, click on the data file you want to select/deselect. This will toggle the check mark indicating whether the file is selected or not. For convenience, the buttons labeled *All* and *None* select/deselect all files; the *Invert* button inverts the selection.

11.2.2 Options

To change the sample interval in pixels, adjust the *Sample step* value. A value of 1 will sample every pixel; higher values will result in a sparser data set.

To export blank values to the output file, with a value of 0, check the *Export blanks* box. If this box is cleared, blank data points will not be present in the output file.

11.2.3 Extracting Data

To begin, click *Start*. You will be prompted for an output .csv file name. A progress bar will appear; when extraction is complete, the dialog will close.

11.3 Extracting Node Data

This option can be used to export spatially sampled data to one or more CSV files.

11.3.1 Adding Sample Points

Exported data is sampled based on X, Y coordinates. You can add a single point at a time, or a line, circle, or grid, by clicking on the appropriate button. This can be repeated as many times as desired to add as many points as necessary. Points on the surface will be displayed as green markers; points which do not fall on the surface for a given data file are shown as red.

To save a set of points for future use, click the disk icon next to the file dropdown. To restore from an existing file, use the file dropdown, or select **Add File**.

11.3.2 Data Files

Use this list to select one or more data files to extract from.

11.3.3 Variables

Select the desired output variables from this list.

11.3.4 Use deformed coordinates

To overlay the selected X, Y points on the *deformed* shape, check this box. To overlay the coordinates on the *initial* shape (while still exporting deformation data), clear the box.

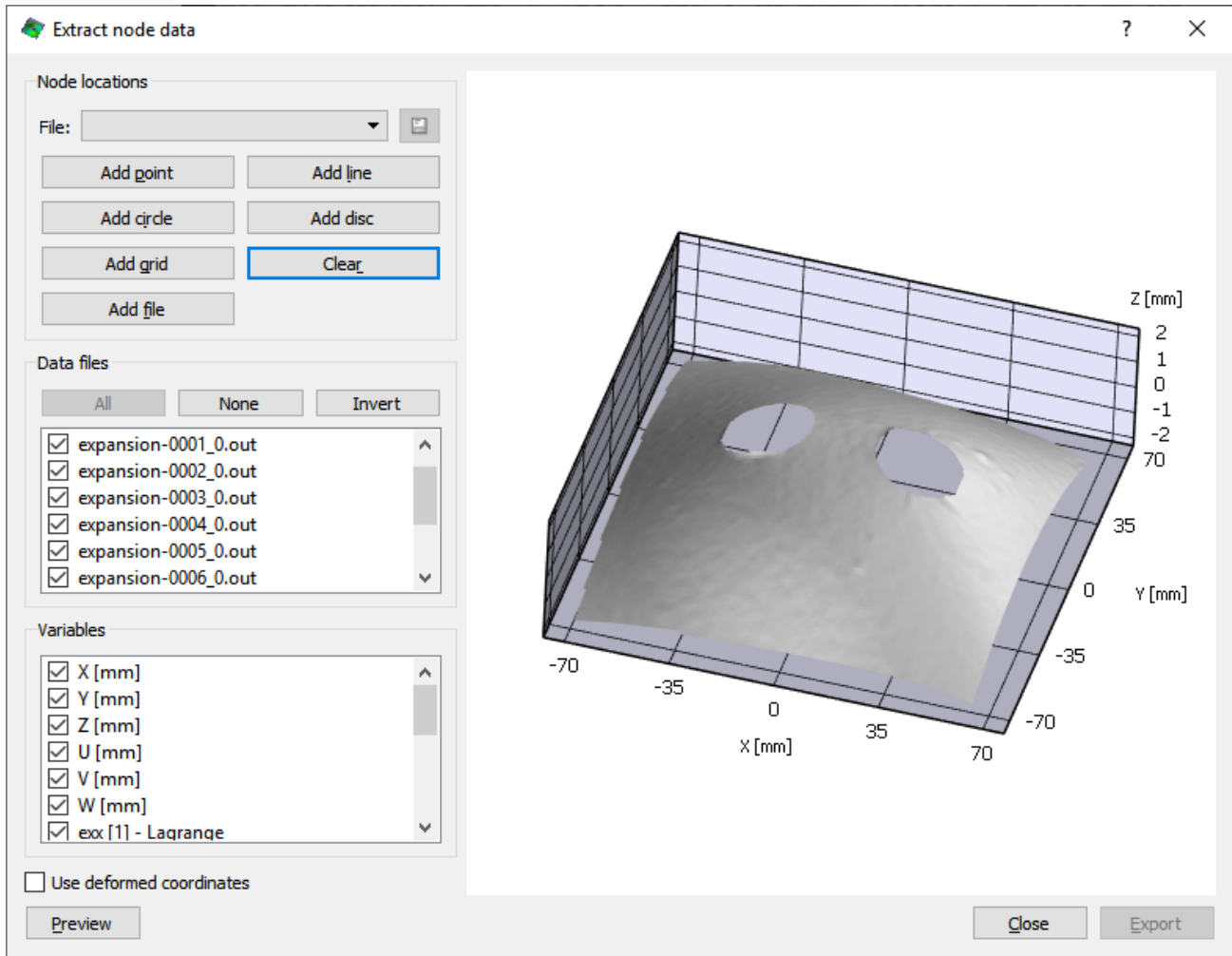

Figure 11.3: Extract node data dialog.

11.3.5 Preview and Export

Click **Preview** to see the position of your points on the selected file. To export the data according to your selected points, click **Export**.

11.3.6 Export Options

After clicking the **Export** button, a dialog with options will appear as illustrated below.

Separate files w/prefix

This option writes a separate file for each data file. A prefix that is prepended to the data file name can be specified in the text input field.

Single file

This option writes all data in a single file. There are two choices for the arrangement of the data:

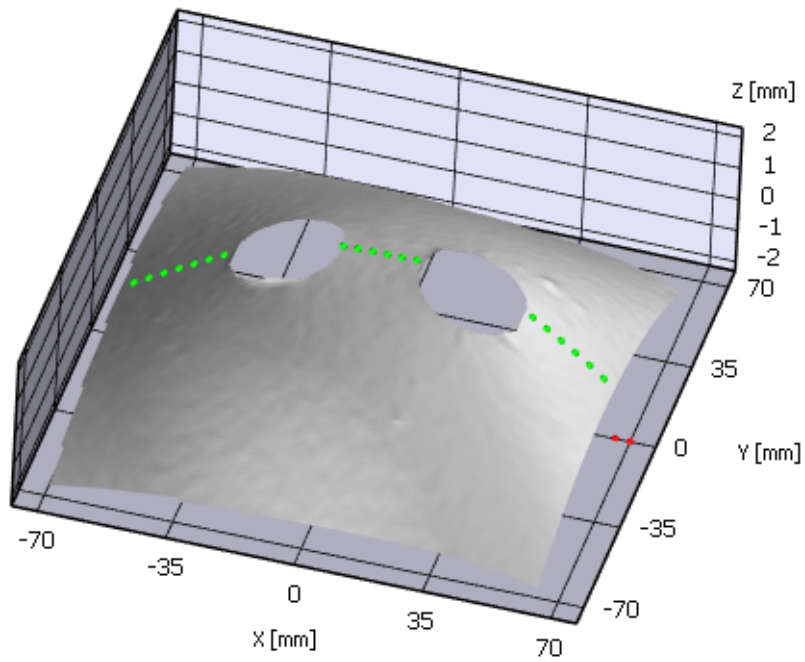

Figure 11.4: Points sampled along a line.

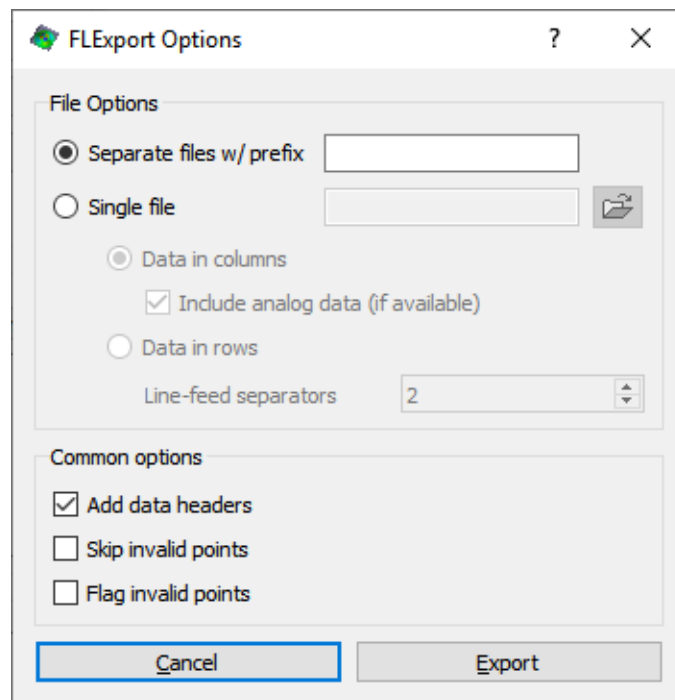

Figure 11.5: Export options dialog.

- **Data in columns:** Each data point is in a separate column, i.e., the rows can be thought of as the time axis. For this data arrangements, the analog data from the project can be added as additional columns.
- **Data in rows:** Each data point is written to a separate row and consecutive data files are separated by the number of blank lines specified in the spin box.

Add data headers

This option writes headers with the variable names.

Skip invalid points

This allows to suppress output of sample points where no data is present.

Flag invalid points

This option adds a `valid_flag` to each data point, indicating whether data is present (1) or not (0).

11.4 Calculating Statistics

To export statistics for calculated variables and data files, select *Data... Statistics* from the main menu bar.

11.4.1 Statistics

Check the desired item to include or exclude the statistic from the output file.

11.4.2 Variables

Check the desired variables to add them to the calculation. By default, all metric variables are included, while correlation and pixel variables are excluded.

11.4.3 Data File Selection

The available data files are displayed in the list box. To select which files to process, click on the data file you want to select/deselect. This will toggle the check mark indicating whether the file is selected or not. For convenience, the buttons labeled *All* and *None* select/deselect all files; the *Invert* button inverts the selection.

11.4.4 Exporting

To complete the calculation, click *Ok*. You will be prompted for a filename, and the data will be exported as a .CSV file.

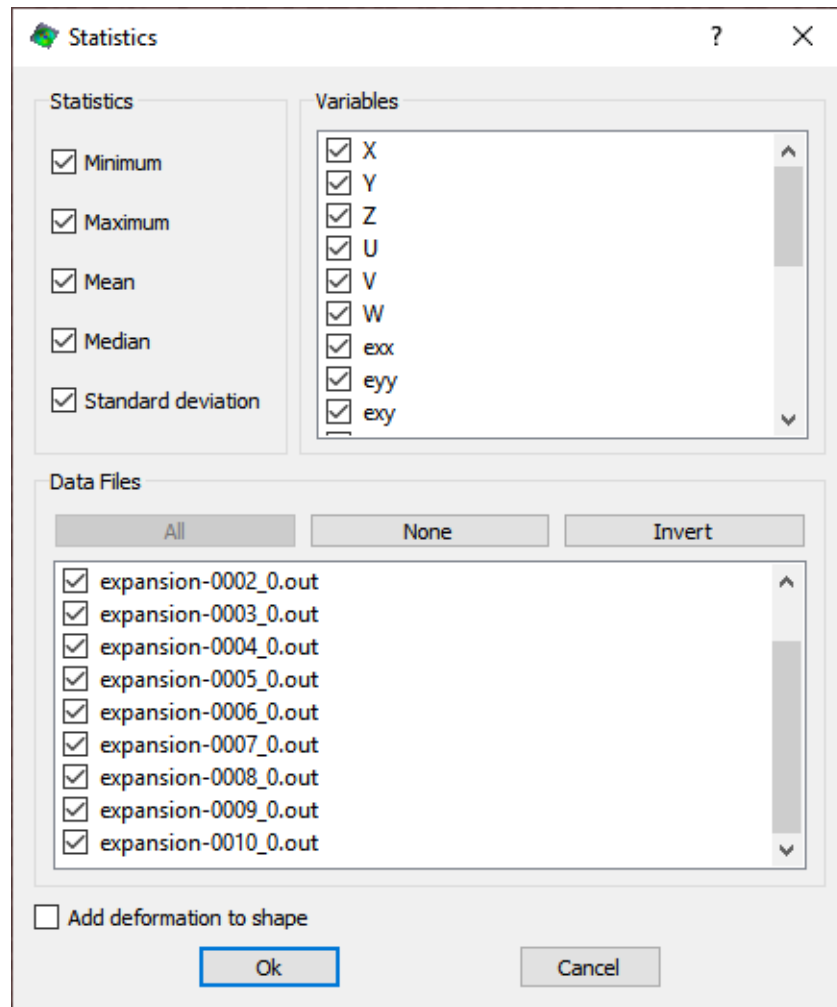
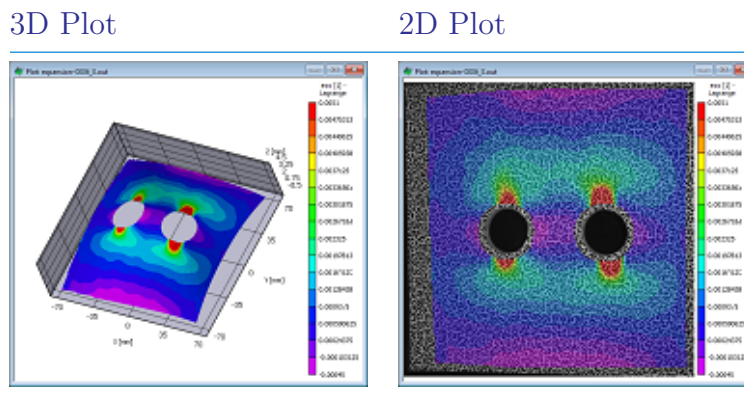

Figure 11.6: Statistics dialog.

Chapter 12

Plotting Data

There are two main facilities to visualize and work with DIC data in the software. For interactive inspection, [2D plots](#) and [3D plots](#) can be used in the main workspace to visualize data as a three-dimensional plot with or without color contour overlay, or as a two-dimensional contour plot overlaid over the speckle image. The two-dimensional plot provides facilities for extracting data from sequences, as well as extracting slices of data.



To generate high quality plots for exporting or to generate animations, the *iris* framework can be used. The *iris* framework can generate publication quality plots and provides flexible tools to generate animated 2D and 3D plots, line plots and more.

12.1 Output Variables

12.1.1 Introduction

During correlation and optional post-processing, Vic-3D presents a wide range of output data available for 3D and contour plotting, extraction, and export.

12.1.2 Output Variables

12.1.2.1 Always Present

- X [mm] - metric position along the X-axis (by default, the horizontal axis).
- Y [mm] - metric position along the Y-axis (by default, the vertical axis).
- Z [mm] - metric position along the Z-axis (by default, the out-of-plane axis).
- U [mm] - metric displacement along the X-axis, from the reference image. For the reference image, displacement values will always be 0.
- V [mm] - metric displacement along the Y-axis.
- W [mm] - metric displacement along the Z-axis.
- sigma [pixel] - this is the confidence interval for the match at this point, in pixels.
- x / y [pixel] - point location in the reference speckle image
- u / v / q / r [pixel] - internal raw disparity measures.

12.1.2.2 Generated in Postprocessing

Strain Variables

- exx [1] - strain in the X-direction. Positive numbers indicate tension; negative numbers indicate compression.
- eyy [1] - strain in the Y-direction.
- exy [1] - shear strain.
- e1 [1] - the major principal strain.
- e2 [1] - the minor principal strain.
- gamma [1] - the principal strain angle in radians, measure counterclockwise from the positive X-axis.

Velocity Variables

- dU/dt [mm/s] - the rate of change of the U-displacement; that is, the velocity of a given point in the X direction.
- dV/dt [mm/s] - velocity in the Y direction.
- dW/dt [mm/s] - velocity in the Z direction.
- dExx/dt [1/s] - the rate of change of strain in X, or strain rate in X.
- dEyy/dt [1/s] - the strain rate in Y.
- dExy/dt [1/s] - the shear strain rate.

Curvature Variables

- cxx [1/mm] - curvature in the X-direction, equivalent to 1/(diameter of curvature).
- cyy [1/mm] - curvature in the Y-direction.
- c1 [1/mm] - the major principal curvature.
- c2 [1/mm] - the minor principal curvature.
- gamma [1] - the principal curvature angle in radians, measured counterclockwise from the positive X-axis.

Rotation Variables

- phi [1] - the in-plane rotation, in radians.

12.1.3 Key Terms

Strain: the change in length, divided by initial length, for a solid material. For example, a strain of +10% indicates that the material has expanded by 10%; a strain of -10% indicates that the material has contracted by 10%. Positive strains are referred to as tensile, while negative strains are compressive. Note: this is a finite strain tensor and contains a quadratic term; for significant strains, this may result in a strain measure which is larger than the small strain indicated by a strain gauge or extensometer.

Principal strain: the strain for a reference frame that is rotated such that shear becomes zero, leaving only two strain components at 90° angles. The larger strain becomes the major principal strain, and the smaller becomes the minor principal strain.

12.2 The Plot Toolbox

The plot toolbox is displayed at the top left edge of the work area by default. It contains options and controls for both the 2D and 3D plots.

12.2.1 Auto-Scaling Tab

The auto-scaling tab shown in Fig. 12.1 controls automatic plot scaling options. Check or clear the boxes to enable/disable auto-rescaling of either coordinate axes limits, or contour overlay limits. Check *Grow ranges only* to allow ranges to get larger but not smaller. With this box checked, you can animate through all images to set the limits to the minimum and maximum over all data files. This is useful for producing consistent animations and videos.

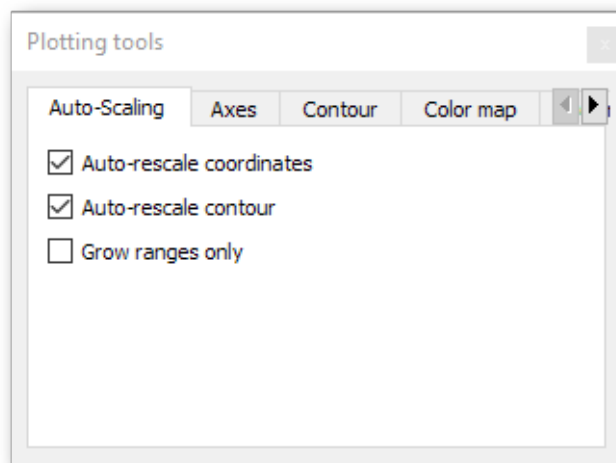

Figure 12.1: Auto-scaling tab.

12.2.2 Axes Tab

This axes tab shown in Fig. 12.2 allows selection of axis limits and Z-scaling, when auto-scaling is turned off. To control the scaling of the Z-axis relative to the X- and Y-axes, change the *Z-scale* value. Larger numbers will exaggerate the Z-axis more.

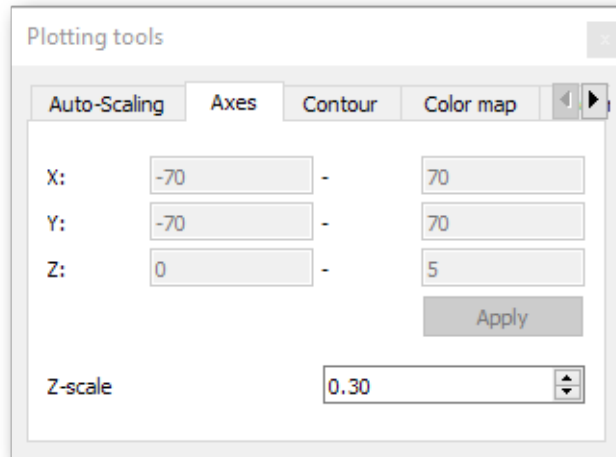

Figure 12.2: Axes tab

12.2.3 Contour Tab

The contour tab shown in Fig. 12.3 allows control of the contour overlay of 2D or 3D plots. The contour variable can be selected from the *Variable* pull-down menu. If auto-scaling is disabled, the contour range can be manually entered in the text boxed. After entering the lower and upper limit of the range, the *Apply* button must be pressed to apply the new range to the plot.

To enable or disable the contour overlay in 3D mode, select *Show contour plot*.

The *strain unit* pull-down menu provides options for selecting different units for strain values, e.g. percent or micro-strain. The default setting is unity, i.e., mm/mm.

12.2.4 Color Map

The color map tab shown in Fig. 12.4 provides options for configuring the display of contour overlays. The *Color map* box chooses the overall color set for the plot. The *Opacity* box sets the opacity of the overlay for 2D plots only. The *Levels* box controls the number of discrete contour levels. The *Level labels* box controls the number of numeric level indicators.

12.2.5 Iso-lines

The iso-lines tab illustrated in Fig. 12.5 is used to configure display of iso-lines on contour plots. The number of iso-lines displayed is determined by the number of contour levels. If many contour levels are selected for a smooth color transition, the iso-lines may be too close to each other. In

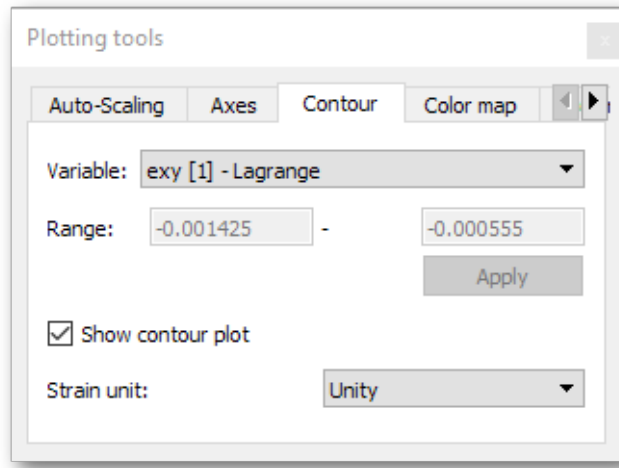

Figure 12.3: Contour tab.

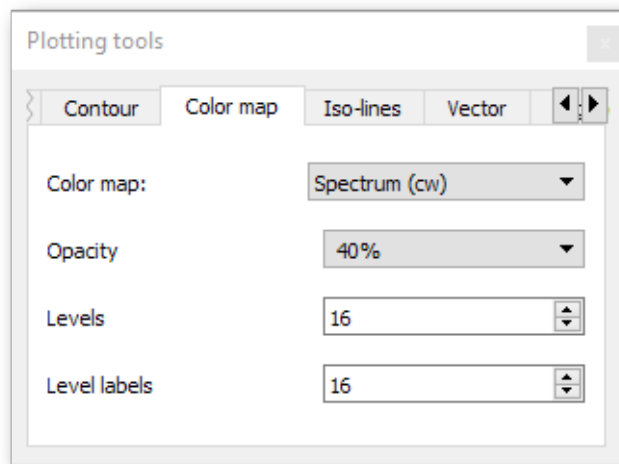

Figure 12.4: Color tab.

this case, the *Level skip* spin box can be used to reduce the number of iso-lines. The thickness of the isolines and the color can also be adjusted.

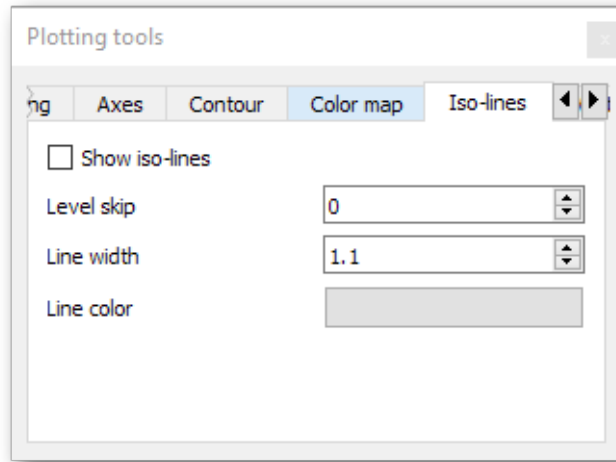

Figure 12.5: Iso-lines tab

12.2.6 Vector

The vector tab controls display of strain and displacement vectors and is illustrated in Fig. 12.6. Major and minor strain direction vectors are displayed on 2D plots only, when strain data is available. Displacement vectors may be viewed in 2D or 3D. *Skip* and *scale* control the size and density of the vectors. The *use solid color* checkbox causes the vectors to be displayed in a single color rather than the underlying plot color. The color selector button can be used to choose the color for solid color vectors.

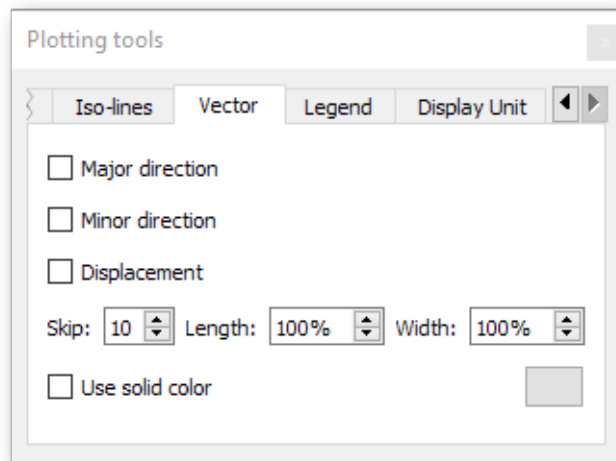

Figure 12.6: Vector tab.

12.2.7 Legend

The legend tab shown in Fig. 12.7 provides options to format the contour legend. Select a *Format* from Number, Scientific (exponential notation), or Best (most concise method). Select a number of *Digits*, or Automatic to use as much precision as necessary.

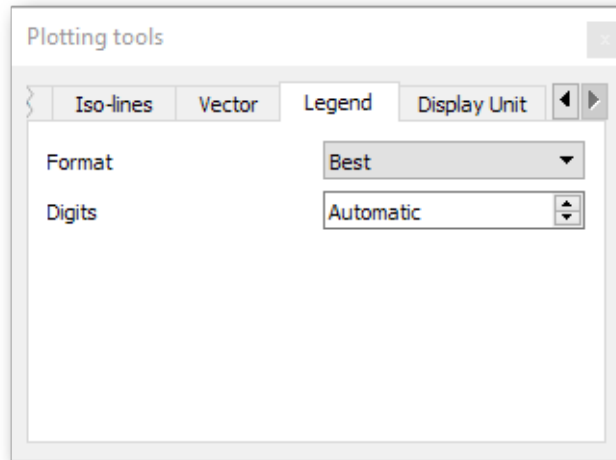

Figure 12.7: Legend tab.

12.3 3D Plots

A 3D plot of the data can be displayed by double-clicking on a data file in the list view to the left of the workspace or by selecting a data file from the *Data... Plot* menu.

A plot will be displayed in the workspace as shown in Fig. 12.8.

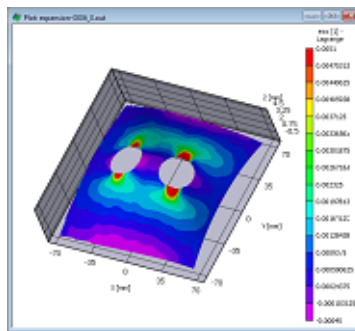

Figure 12.8: Plot window in 3D mode.

12.3.1 Controlling the Plot

To rotate the plot, click and drag in the plot window. To zoom in and out, rotate the scroll wheel. To pan around the plot, click and hold the scroll wheel and move the mouse.

12.3.2 Plot Options

Plot options can be accessed by right-clicking in the plot window as illustrated in Fig. 12.9. This displays a context menu with options to manipulate the plot.

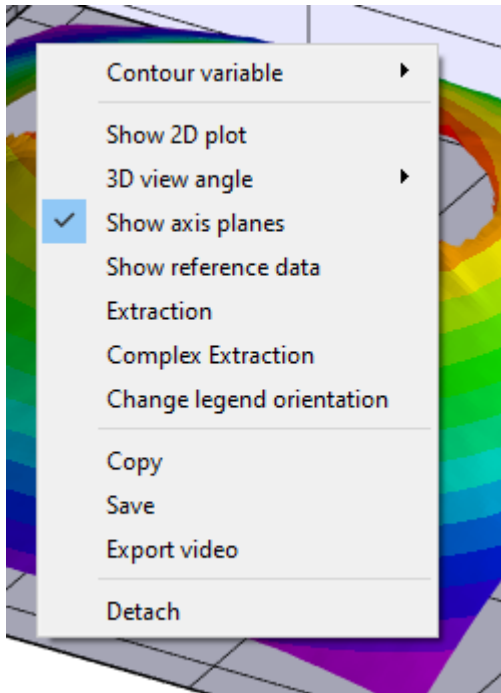

Figure 12.9: Context menu in 3D plots.

To switch to a 2D plot, select *Show 2D Plot* from the context menu, or click *2D* in the main toolbar (see [Section 2.10](#)).

Use the *View* submenu to select a planar view or revert to the default view.

The *Contour variable* submenu can be used to select the variable to display.

Click *Change legend orientation* to toggle between a horizontal and vertical legend.

Copy copies the current plot to the clipboard; *Save* allows saving the plot as an image file.

Select *Export video* to save a video. More details can be found in [Section 12.5](#).

Click *Detach* to keep this plot static instead of updating it each time a new data file is clicked in the *Data panel* (see [Section 3.3.2](#) for details).

To change other plot parameters, such as axis ranges, contour line display, contour levels etc., controls are provided in the *Plot tool box*, see [Section 12.2](#) for details.

12.3.3 Animating Plots

To animate 3D plots, bring up the plot display and then use the controls on the Animation Toolbar (see [Section 2.11](#)) to animate the sequence.

12.3.4 Saving the Plot

The displayed plot can be saved as a BMP, PNG, or JPG image file by selecting *Save* from the context menu. To copy the plot to the clipboard, select *Copy*.

12.4 2D Plots

A 2D plot of the data can be displayed by double-clicking on a data file in the list view to the left of the workspace, and then clicking *2D* in the [main toolbar](#) or clicking *Show 2D plot* in the [plot context menu](#).

A plot will be displayed in the workspace as shown below.

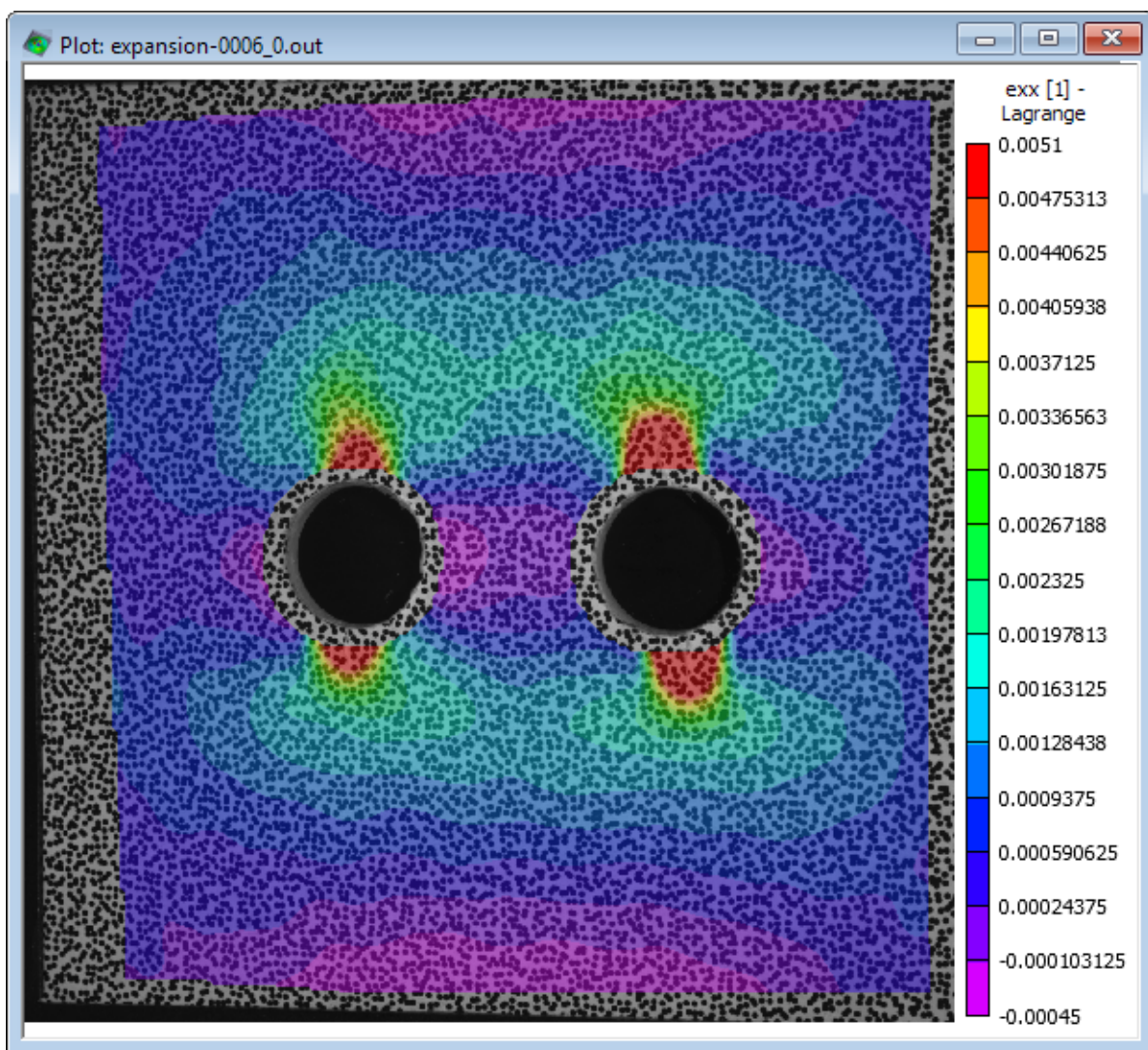

Figure 12.10: 2D contour plot display.

12.4.1 Plot Options

Plot options can be accessed by right-clicking in the plot window.

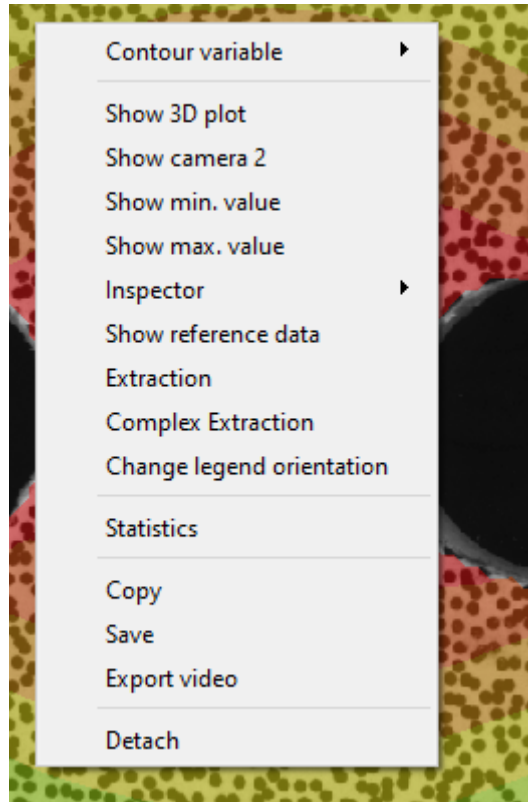

Figure 12.11: 2D plot context menu.

The *Contour variable* submenu can be used to select the variable to display.

To switch to a 3D plot, select *Show 3D Plot* from the context menu, or click *3 D* in the [main toolbar](#).

Click *Show camera 2* to change the underlying speckle image to the other camera view.

The *Show min. value* and *Show max. value* options will flag the minimum and maximum valued data points.

By default, data is displayed in the deformed location on the deformed image. To show the reference position for the data, click *Show reference data*.

Click *Change legend orientation* to toggle between a horizontal and vertical legend.

Click *Statistics* to view a summary of data for the current image, for the currently selected contour variable.

Copy copies the current plot to the clipboard; *Save* allows saving the plot as an image file.

Select *Export video* to save an [animated video](#).

Click *Detach* to keep this plot static instead of updating it each time a new data file is clicked in the [Data](#) tab.

12.4.2 Editing Plot Parameters

To edit other plot parameters, use the [plot toolbar](#).

12.4.3 Inspector Tools

Tools for probing and extracting data are located in the Inspector Toolbar, and can also be selected by clicking *Plot... Inspector* in the main menu bar.

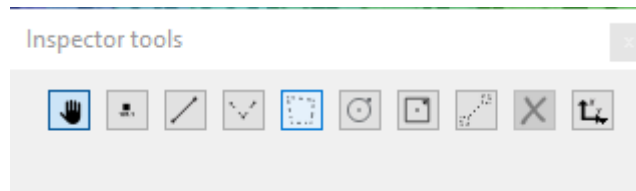

Figure 12.12: Inspector tools.

From left to right, the tools are:

- Pan/Select: Pans around the contour image, when zoomed in; selects existing extract points. To select an item, click on the small square handle.
- Inspect point: select this tool and click to probe at a single point. The value for the currently selected contour variable, at the chosen point, will be displayed.
- Inspect line: select this tool and click once to start a line; click again to finish. The value will be displayed at each node.
- Inspect polyline: select this tool and click to create line nodes; double-click to finish. The value will be displayed at each node.
- Inspect polygon select this tool and click to define a polygon. Values will be displayed at each node; the average will be extracted.
- Inspect circle: select this tool and click to define a center; click again to define a disc. The average value will be displayed at the center node.
- Inspect rectangle: select this tool and click to define a center; click again to define a rectangle. The average value will be displayed at the center node..
- Extensometer: select this tool and click two points; this tool shows the extension (change in length divided by initial length) between the two points.
- Delete: choose this tool and click on an existing point/line/area to remove it.
- Extract: a simple click opens an [Extraction Plot](#), pressing and holding this button provides a menu with additional options, see [Section 12.7](#) for details.

Once a tool is selected, you can place it on the plot by clicking.

- For the point tool, click once to place the point.
- For the circle, rectangle, and line tools, you can click once to place the first point, and again to define the shape.

Once a tool is placed, you can use the Pan/Select tool to move the inspector or to adjust the control points.

12.4.4 Animating Plots

To animate contour plots, bring up the plot display and then use the controls on the [Animation Toolbar](#) to animate the sequence.

12.4.5 Saving the Plot

The displayed plot can be saved as a BMP, PNG, or JPG image file by selecting *Save* from the context menu. To copy the plot to the clipboard, select *Copy*.

12.5 Exporting Videos

To export an animation from a 2D or 3D plot, right-click in the plot and select *Export Video*.

If the auto-rescaling feature is enabled for contours or axes, you will see a warning:

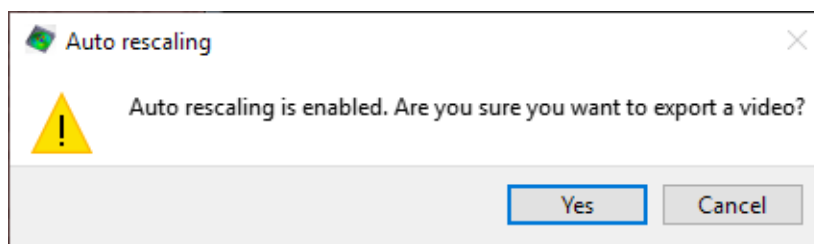

Figure 12.13: Warning message when auto rescaling enabled.

When rescaling is on, the animation may not appear as expected because each frame will be scaled differently. Click *Yes* to continue or *Cancel* to correct the condition. When complete, the following dialog appears:

12.5.1 File

Click the icon to select a filename for saving.



Vic-3D requires a file extension to be entered before saving. When typing the file name, add the desired file extension to the end of the file name (this can also be changed afterwards via the Format dropdown menu). For e.g. “Composite_Exx_3D.mp4” will write a file in mp4 format.

The following file extensions are accepted:

-Videos: mp4, wmv, avi

-Individual frames: bmp, jpeg, jpg, tiff, etc. A full list is show in the ‘Format’ dropdown menu

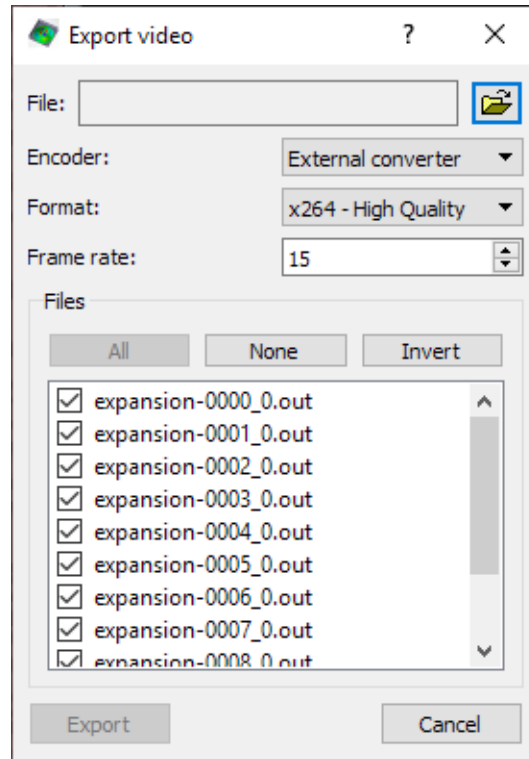

Figure 12.14: Video export dialog.

12.5.2 Encoder

- To use the built-in codecs, select *AVI*.
- To use a choice of external codecs with a supported external encoder, select *External converter*.
- Select *Image Sequence* to export a sequence of numbered individual images rather than a video.

12.5.3 Format

Select from available compression formats; options will vary based on system configuration and installed codecs.

For videos which will be recompressed, select RGB Uncompressed to make a very large but lossless video.

12.5.4 Data File Selection

The available data files are displayed in the list box. To select which files to process, click on the data file you want to select/deselect. This will toggle the check mark indicating whether the file is selected or not. For convenience, the buttons labeled *All* and *None* select/deselect all files; the *Invert* button inverts the selection.

To begin, click *Export*; a progress bar will indicate completion.

12.6 Extraction Plots

Extraction plots can be generated for the dataset as a whole, or for lines, points, and areas by using the **Inspector Tools** in a 2D plot. An extraction data plot as illustrated in Fig. 12.15 will be shown when the *Extract* button () is pushed while viewing a 2D Plot. Note that an extraction plot can be generated even if no inspector items are present. In this case, only the average values will be available for plotting. Depending on the types of inspector items that have been added to the contour plot, different plot types will be available:

- Points (default) for average, points, area averages.
- Line slices for lines and polylines.
- Extensometers.
- Points and Extensometers.

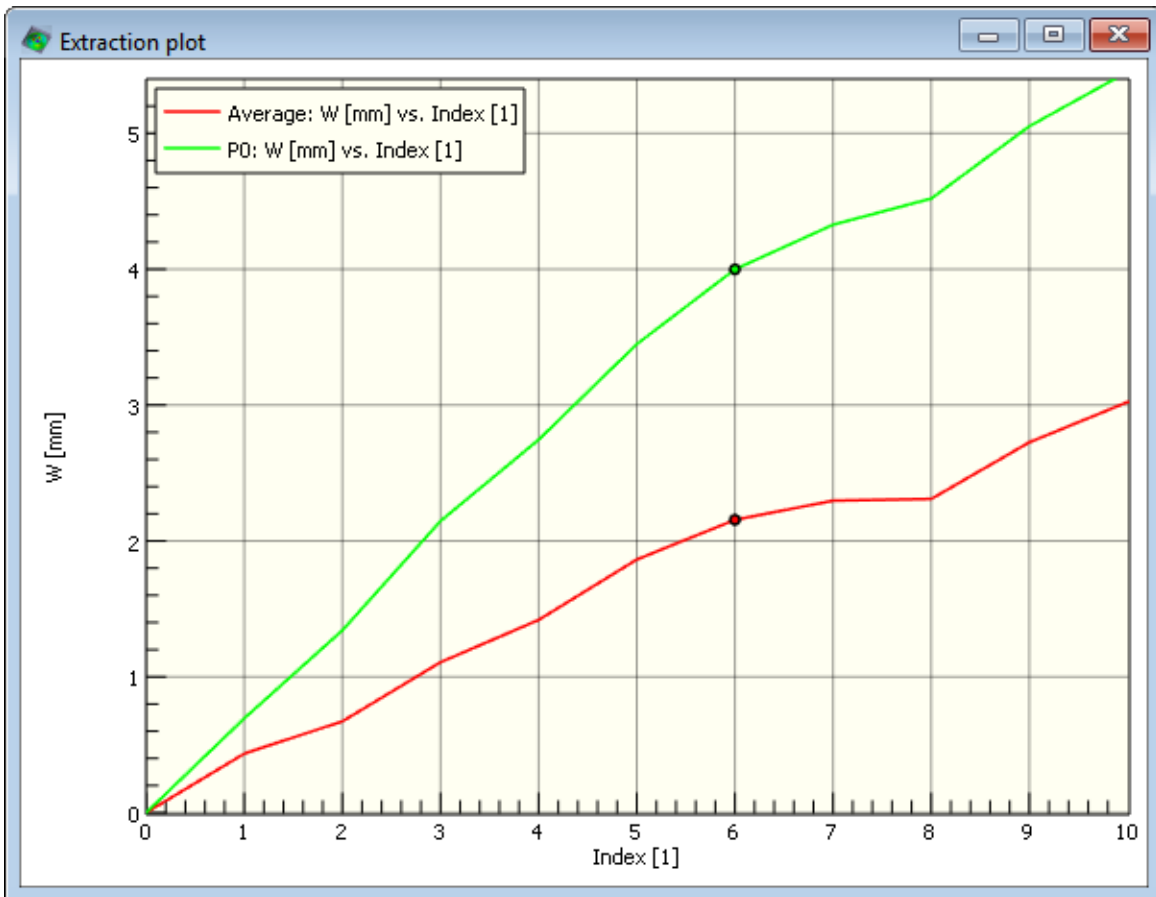

Figure 12.15: Extraction plot.

A long press on the () button will allow selection of **Complex plot extraction**

12.6.1 Selecting X/Y Data for Plotting

Each X/Y data pair shown in the plot will be listed in the *Extraction tools* tool box (see Fig. 12.16) and shown in the plot's legend (if configured, see Section 12.6.8). The X/Y data that is shown in the plot can be edited in the tool box.

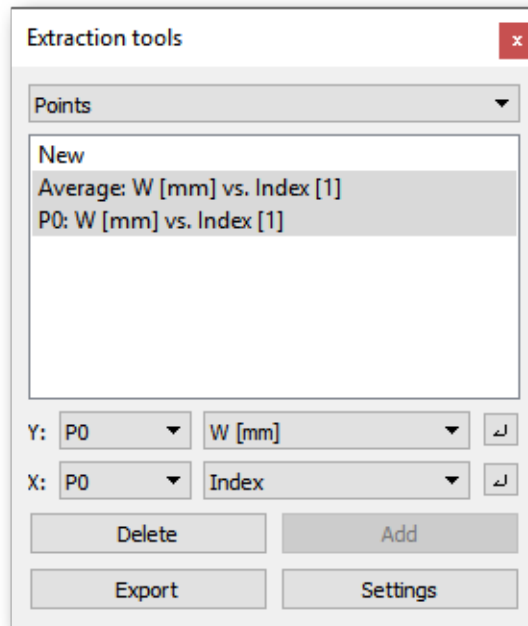

Figure 12.16: Extraction plot tool box.

To select the variables for a new or an existing X/Y pair, the X/Y data source and variable can be selected from the drop-down menus below the list box. Available data sources are:

- Average corresponds to the average value from the entire data set.
- P0, R0, C0, etc. are the values corresponding to inspector tools (points, rectangles, circles etc).
- Analog data corresponds to CSV data added to the project. This is normally a file generated by Vic-Snap.

After the variables for X or Y have been selected from the menus, the apply button on the right must be pressed to apply the changes. Note that the change applies to all X/Y pairs selected in the list box.

To delete an X/Y pair, the item must first be selected in the list box, followed by pressing the **Delete** button.

New X/Y data pairs can be added to the plot by first selecting the *New* item in the list box at the top. Then, the data source and variables can be selected from the drop-down menus and the new X/Y pair is finally created by clicking the **Add** button.

To export plot data, the **Export** button can be pressed to bring up the [Export data wizard](#).

12.6.2 The Extractions Menu

Only present in Vic-3D 9 the extractions menu allows for deleting of extractions as well as re-opening past extractions.

The main purpose of this workspace is to open past extractions to manipulate the data for use in the iris workspace.

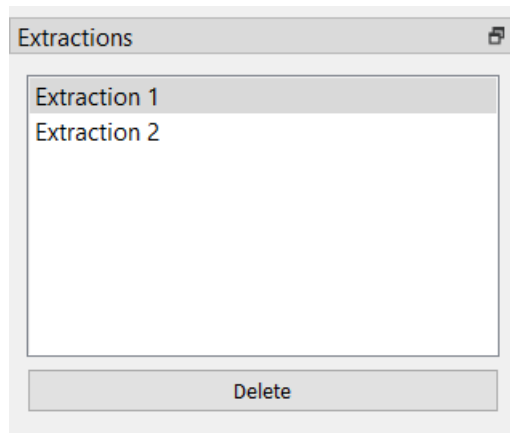

Figure 12.17: Extractions menu.

12.6.3 Navigating in the Plot

Use the mouse wheel to zoom in or out on the plot. Click and drag to pan; double click to fit the plot to the window.

To adjust a single axis scale, mouse over that axis; the cursor will change to indicate the axis is active. Then, use the mouse wheel to zoom only that axis.

To zoom to a selected box, hold the shift key and drag to indicate the zoom area.

12.6.4 The Context Menu

Right-click in the plot to access options.

- Cursor: select from axis indicators for X, Y, or both axes; select Snap Cursor to display the value reading closest to the cursor.
- Copy: copies the plot to the clipboard.
- Save: select to save the plot as a graphics file.
- X/Y axis scale: submenus allow changing between linear and logarithmic axis scaling.
- Settings: click to access the [plot settings](#).
- Quick help: display a brief overview of the plot navigation controls.

12.6.5 Point Extractions

By default, extraction plots are shown in *Point* mode, which displays the average data as well as data generated by inspector items of type point and those that average over an area (discs,

rectangles etc.). The plot type can be selected from the drop-down menu at the top of the extraction tool box, see Fig. 12.16.

12.6.6 Line Slice Extraction and Plotting

Line slices may be plotted only when an extraction line or polyline is present. They can be created using the [Inspector Tools](#) to add lines or polylines to a 2D contour plot. An example of a line slice inspector item is illustrated in Fig. 12.18.

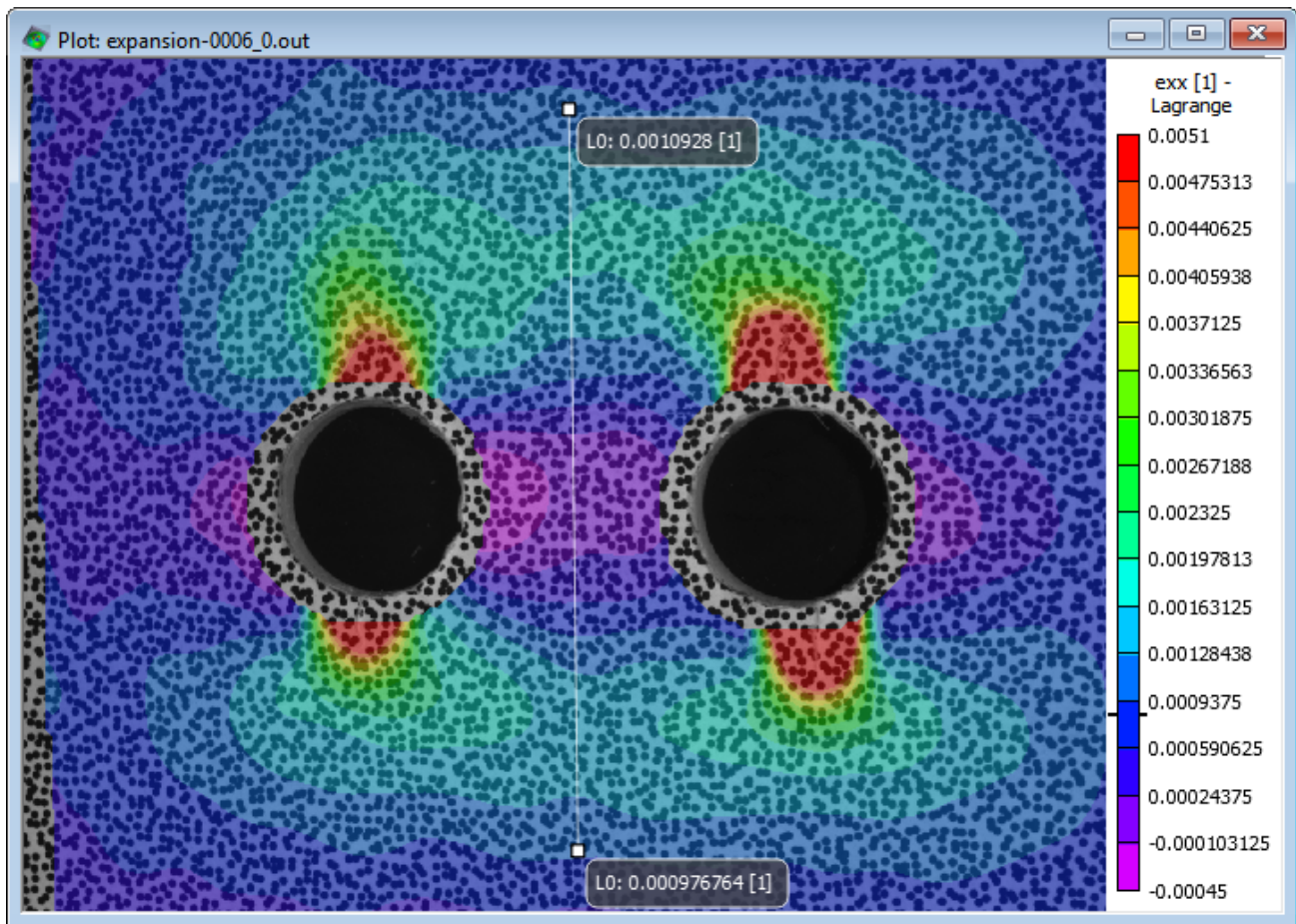



Figure 12.18: Line slice in contour plot.

After clicking the *Extract* button () an extraction plot will appear in the workspace, but will initially show the available *Point* extractions. To display the line extraction, the entry *Line slices* must be selected from the pull-down menu in the extraction tool box as illustrated in Fig. 12.19.

On the plot, a series of lines will be shown that shows the extracted data at different times. The line for the currently selected data file will be highlighted, as illustrated in Fig. 12.20. The number of lines that are shown in the plot can be configured in plot settings, see [Section 12.6.8](#).

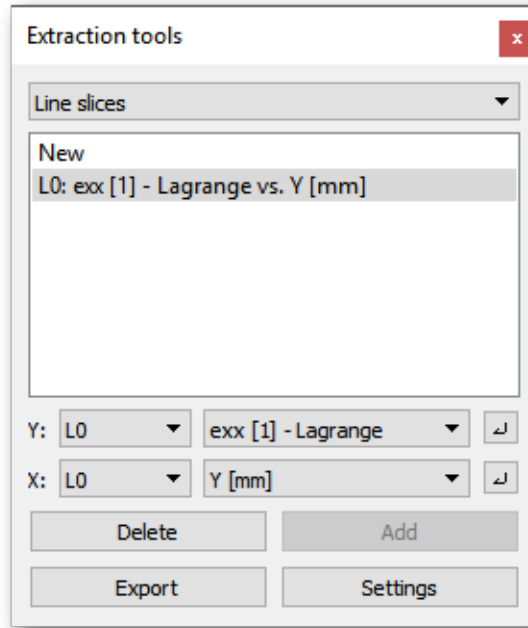

Figure 12.19: Extraction tool box for lines slices.

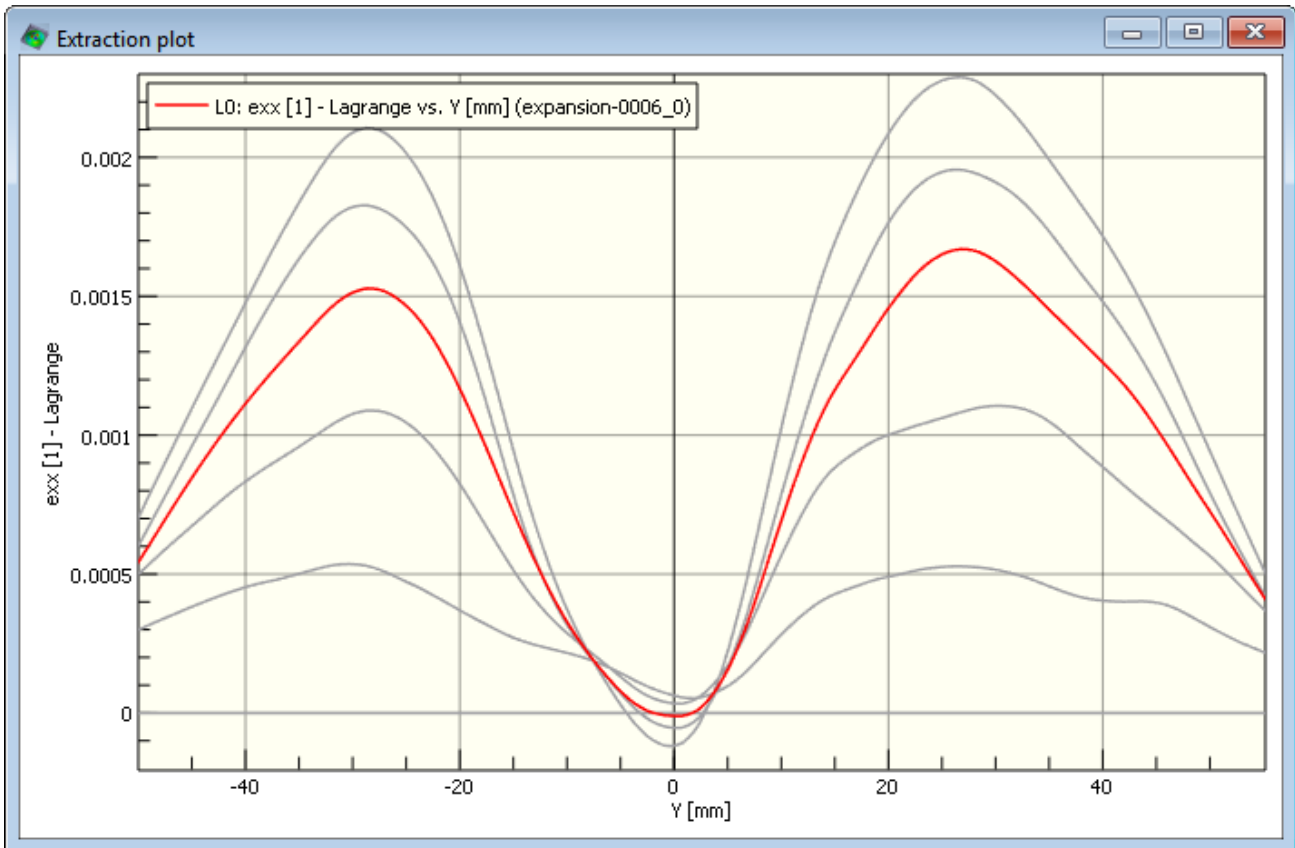

Figure 12.20: Line slice plot.

12.6.7 Extensometer Extraction and Plotting

Extensometer plotting will be available when one or more extensometers have been created using the *Inspector Tools* in a 2D plot view as illustrated in Fig. 12.21.

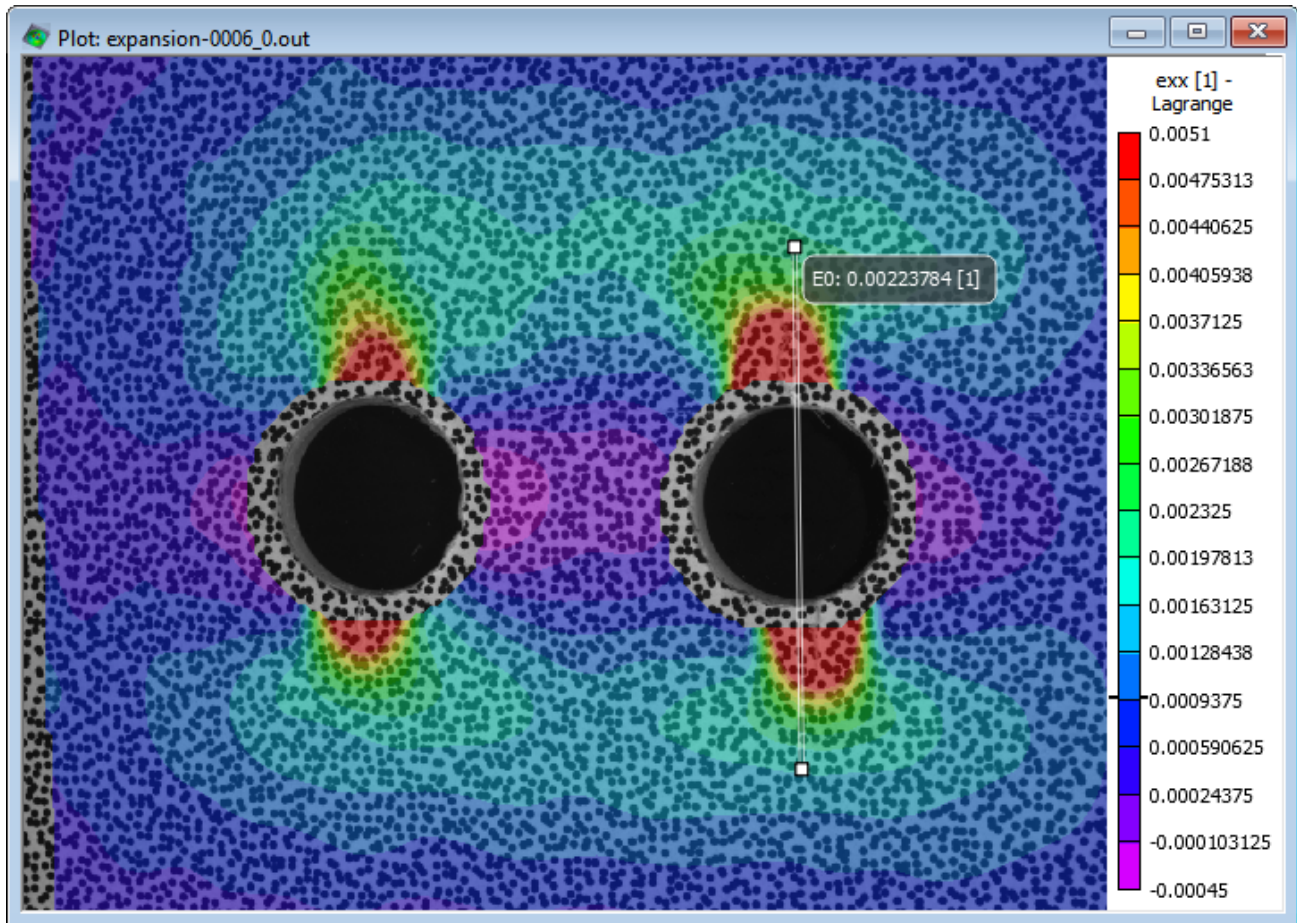



Figure 12.21: Extensometer in contour plot.

Clicking the *Extract* button () brings up the plot window. To switch the display to extensometers, the entry *Extensometers* must be selected from the pull-down menu at the top of the extraction tool box as illustrated in Fig. 12.22. If both points and extensometers are present, the entry *Points and extensometers* will also be available to show extensometer and point extraction data in a single plot.

12.6.7.1 Extensometer Variables

The extensometer plot can be used to show a number of variables that are available for each extensometer extraction, including the relative change in length as illustrated in Fig. 12.23.

The available extensometer variables are:

- $\Delta L/L_0$: The change in length divided by the initial length; unitless.
- ΔL : The change in length, in display units.

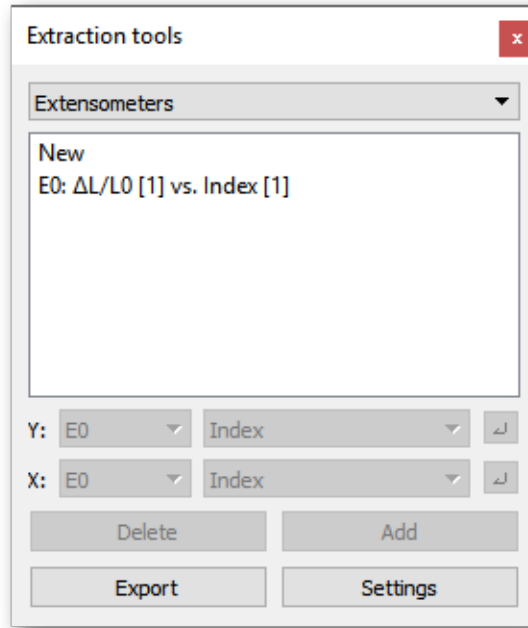

Figure 12.22: Extraction plot tool box for extensometers.

- L1: The deformed length, in display units.
- L0: The initial length, in display units.

i The strain displayed here will not necessarily match the strain computed in the [Strain dialog](#), depending on the tensor you have selected. The extensometer strain is a simple length calculation and does not account for bending, etc.

12.6.8 Plot Settings

The plot settings can be accessed from the context menu of the plot (see [Section 12.6.4](#)). This displays a dialog with different options to control the plots as illustrated in [Fig. 12.24](#).

The first tab controls graph display settings.

- Graph style: select from lines, points, or both. If Points is selected, you can use the snap cursor to evaluate values at specific locations in the plot. With Lines selected, the snap cursor will give an interpolated value.
- Show legend: click to show or hide the legend.
- Legend position: select the location of the displayed legend on the plot.
- Theme: choose from a white background scheme (“Daytime”) or a black background scheme (“Midnight”).

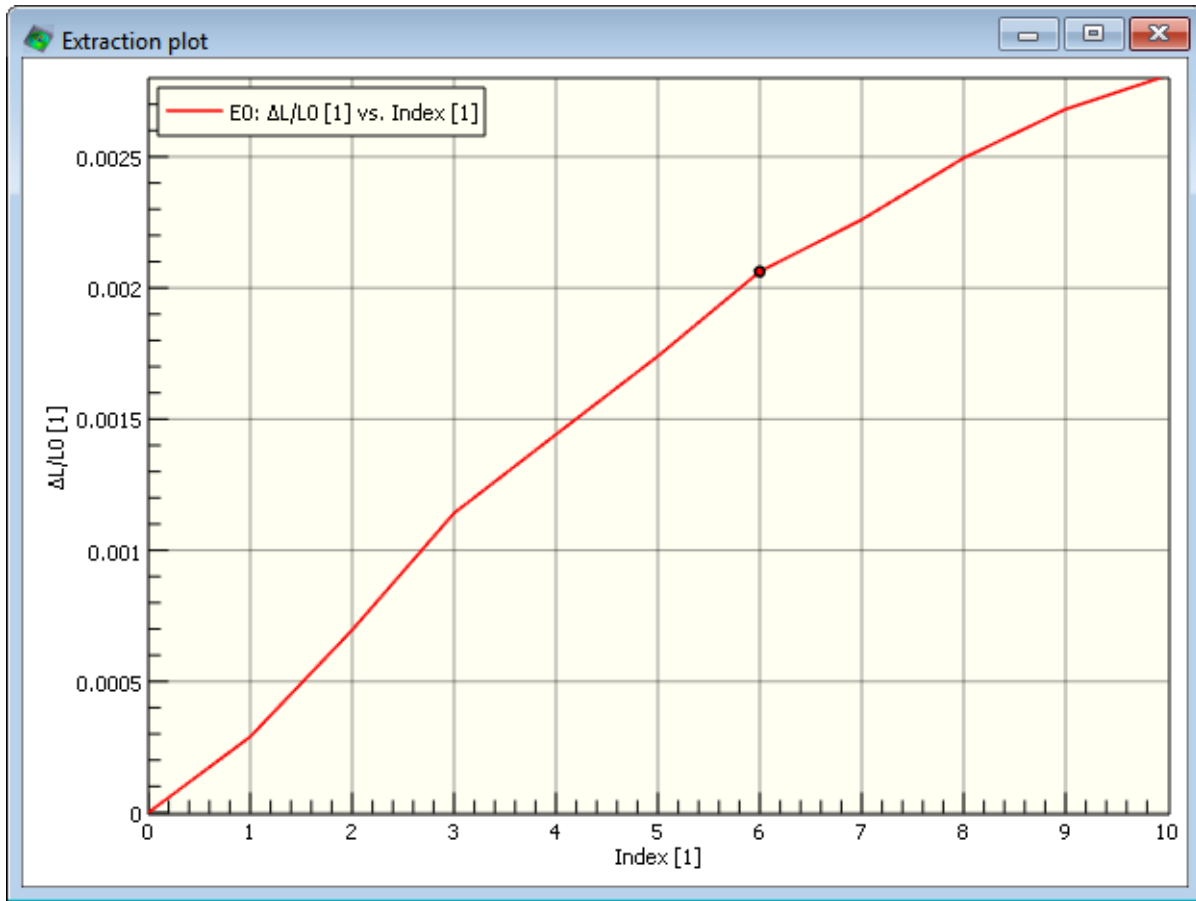

Figure 12.23: Extensometer extraction plot.

The second tab applies to time extraction only. You can select whether to highlight the currently displayed data file; and select which data files to plot. All are plotted by default.

The third tab applies to line slice extractions only.

Under Mode, you can choose to display lines for the current file and the select files; only the current file; or only the selected files (select files from the list below). You can also adjust the style of the non-selected lines as well as the color for them.

Select the files to be extracted from the list at the bottom.

By default, 200 points are created along the extracted line. Since the line does not necessarily pass through exact data points, data points are interpolated at equidistant intervals along the line. The number of sample points can be changed by pressing the **Change** button. This will display an spin box control where the desired number of points can be selected. Note that changing the number of points results in the data being extracted again. The progress of this operation is indicated in a progress bar at the bottom of the plot window.

12.6.9 Exporting Slice Data

To export data, click **Export** in the extraction tool box. The *Export Data Wizard* will appear.

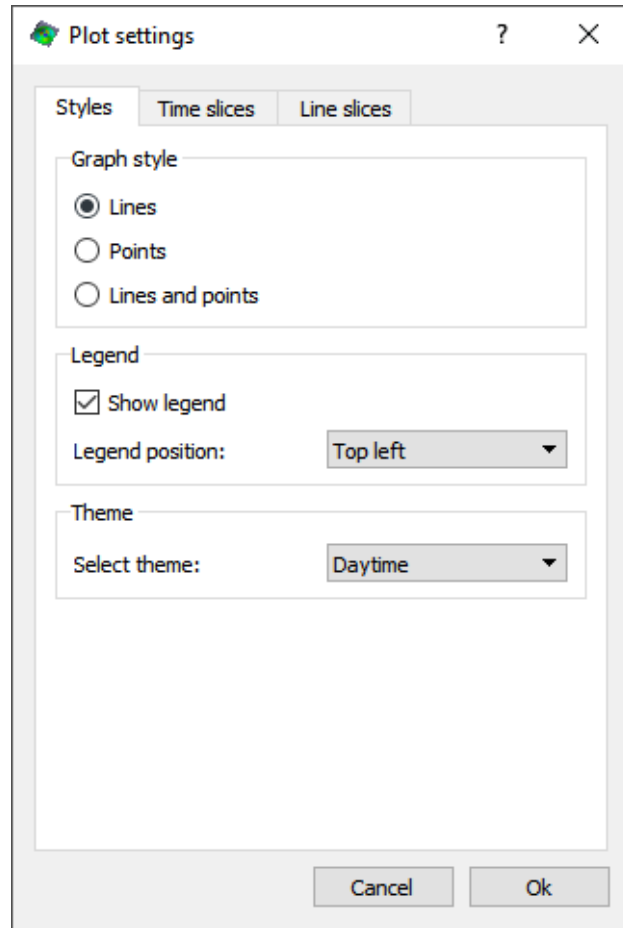



Figure 12.24: Plot settings style tab.

- Output file: click the folder icon to choose an output file.
- Data type: choose from line slice or time extraction.
- Format: select from comma separated (typical for use with Excel) or tab separated.
- Ordering: select row index to have a row for each file (most common), or column index to have a column for each file (useful for making waterfall type plots).
- Coordinates: if you select reference coordinates, the XYZ values will not change over time. Select deformed coordinates to add UVW deformation to the XYZ values, making them change with time.

12.7 Complex plot extractions

Holding the  button will allow selection of Complex plot extractions via a dialog box.

While the simple extraction is limited to average values, complex extractions allow selection of statistical functions (minimum, maximum, mean, median, standard deviation) with the **Statistics** group.

The **Data Files** group allows selecting a subset of data.

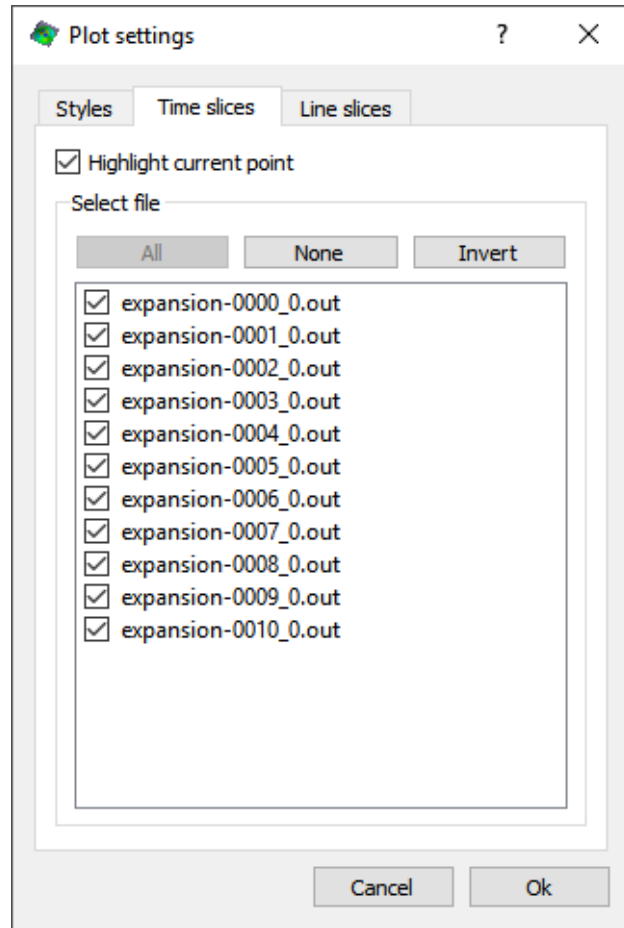

Figure 12.25: Plot settings time slice tab.



Extracting a limited number of data files can improve extraction speed when accessing a slow or networked drive.

12.7.1 Rotation angles

Rotation angles may be calculated by checking **Add rotation angles**. This computes rigid-body transformation (rotation) angles for area-type inspector items (discs, rectangles etc.). The transformation matrix can be computed from the pitch, yaw and roll angles α , β and γ as follows:

$$\mathbf{R} = \begin{bmatrix} \cos(\beta) \cos(\gamma) & \sin(\alpha) \sin(\beta) \cos(\gamma) - \cos(\alpha) \sin(\gamma) & \cos(\alpha) \sin(\beta) \cos(\gamma) + \sin(\alpha) \sin(\gamma) \\ \cos(\beta) \sin(\gamma) & \sin(\alpha) \sin(\beta) \sin(\gamma) + \cos(\alpha) \cos(\gamma) & \cos(\alpha) \sin(\beta) \sin(\gamma) - \sin(\alpha) \cos(\gamma) \\ -\sin(\beta) & \sin(\alpha) \cos(\beta) & \cos(\alpha) \cos(\beta) \end{bmatrix}$$

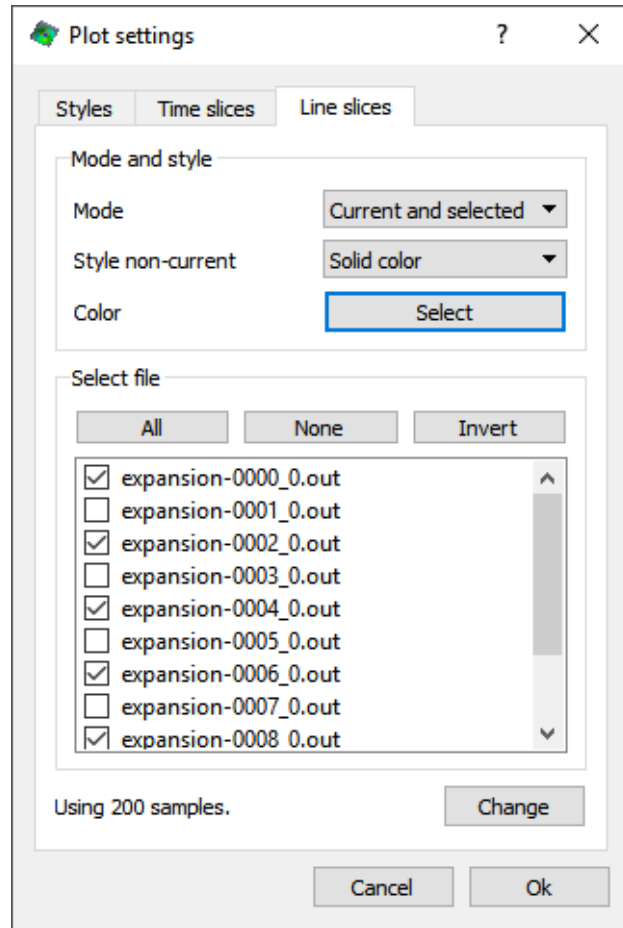

Figure 12.26: Plot settings line slice tab.

The translation component of the rigid body transformation can be computed from the location of the area's centroid X_0, Y_0, Z_0 and the average displacement as follows:

$$\mathbf{T} = \begin{Bmatrix} \bar{U} \\ \bar{V} \\ \bar{W} \end{Bmatrix} + \begin{Bmatrix} X_0 \\ Y_0 \\ Z_0 \end{Bmatrix} - \mathbf{R} \begin{Bmatrix} X_0 \\ Y_0 \\ Z_0 \end{Bmatrix}$$

Note that the transformation given by \mathbf{R} and \mathbf{T} transforms reference coordinates into the deformed state.

Check **Add deformation to shape** to add the variables X_d, Y_d and Z_d to the data set. These are the deformed values $(X+U)$, $(Y+V)$ and $(Z+W)$.

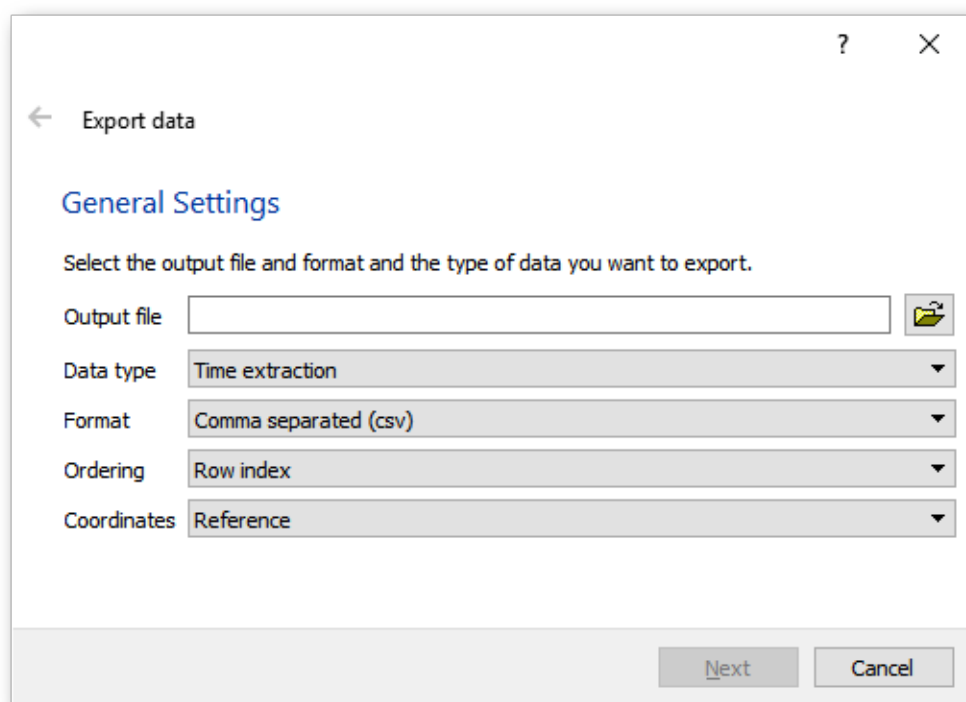

Figure 12.27: Extraction plot export wizard.

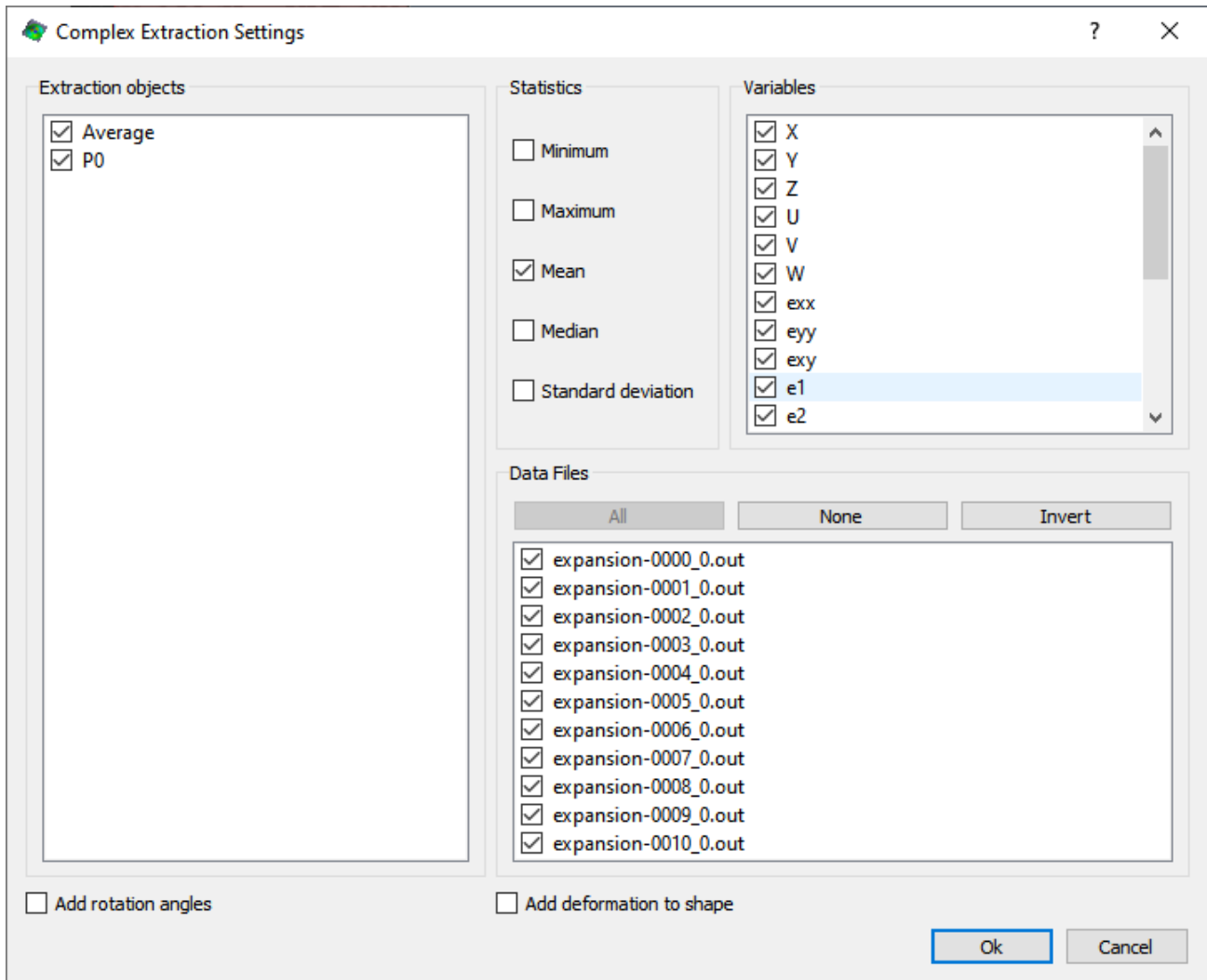



Figure 12.28: Complex extraction settings.

Chapter 13

Data Visualization in *iris*

The *iris* visualization framework provides a workspace for generating both static and animated plots of DIC and imported data, e.g., FE meshes. Some of the features include:

- High resolution rendering for bitmap content and scalable fonts and graphics for publication-quality output
- Most properties can be animated, e.g., position, opacity, rotation, viewing angles etc.
- Motion-tweening with a variety of easing functions
- Adaptive motion blurring for realistic video output
- Data can be interpolated in time to provide smooth high framerate video output from sparse data
- Document and page templates

To begin using *iris*, click the  icon on the toolbar.

For more information, see the following topics:

- [Overview of the *iris* Workspace](#)
- [Pages, templates, and backgrounds](#)
- [Graphic elements](#)
- [Working with Sequences](#)
- [Working with Keyframes](#)
- [Document Properties](#)
- [Exporting *iris* Content](#)

13.1 Overview of the *iris* Workspace

The *iris* workspace contains all of the tools and controls for creating *iris* documents. The workspace replaces the analysis workspace when the  icon is clicked in the toolbar. An overview of the workspace is shown in Fig. 13.1.

The *iris* workspace contains:

- **Main toolbar** - has controls for inserting new objects like plots and images; alignment controls; and buttons for exporting PDF and video.

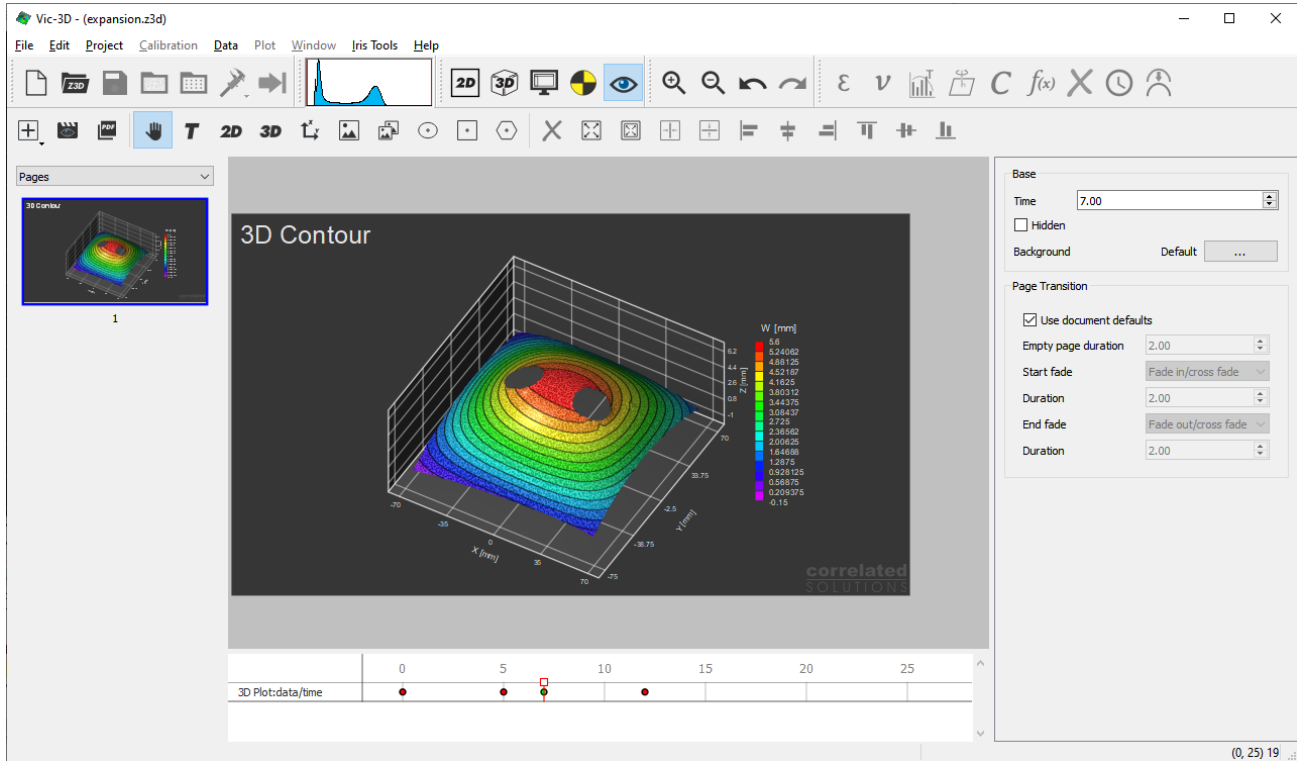

Figure 13.1: Overview of main window.

- **Page/template/backgrounds organizer** - the left sidebar shows a graphical list of pages, templates, and backgrounds, selectable from the pulldown.
- **Properties editor** - the right sidebar has a list of adjustable properties for the currently selected item.
- **Timeline** - the timeline area at the bottom of the window shows all the timelines and keyframes in the project and allows scrolling through time.
- **Main work area** - where all objects/text/graphics will be placed and manipulated.

13.1.1 Editor Context Menu

Right clicking inside the *iris* editor allows for quick adjustment of view, inserting of plot elements, alignment, and exporting. The context menu is shown in Fig. 13.2.

- **Fit Page** - Fits the page size to fill the screen
- **Fit to content** - Fits all of the elements in your workspace to fill the screen
- **Export video** - Opens the video export dialog
- **Export PDF** - Opens the PDF export dialog
- **Sequence Manager** - Opens the sequence manager dialog

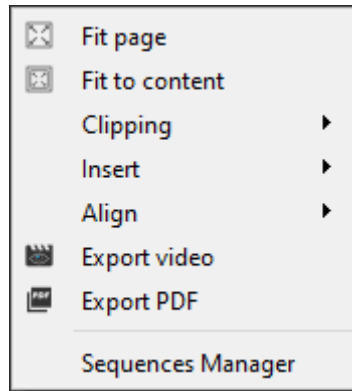

Figure 13.2: Detail of Context menu.

13.1.1.1 Insert Submenu

The *Insert* submenu can be used to conveniently add objects to the page. Note that the inserted object's top-left corner will be placed where the context menu was opened by clicking. The insert menu is illustrated in Fig. 13.3.

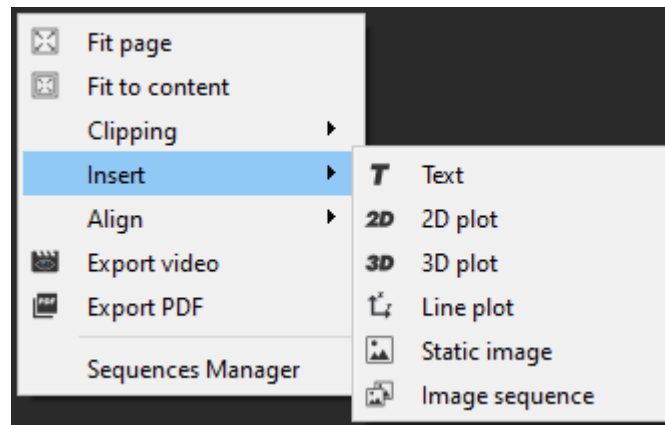

Figure 13.3: Detail of Insert submenu.

- [Text boxes](#)
- [2D plots](#)
- [3D plots](#)
- [Extraction plots](#)
- [Static images](#)
- [Image sequences](#)

13.1.1.2 Align Submenu

The *Align* submenu can be used to align objects to the page or relative to each other. To align objects relative to each other, multiple objects must be selected. The last object selected will be

the stationary object, i.e., all other objects in the selection are aligned to the last object selected. The align menu is shown in Fig. 13.4.

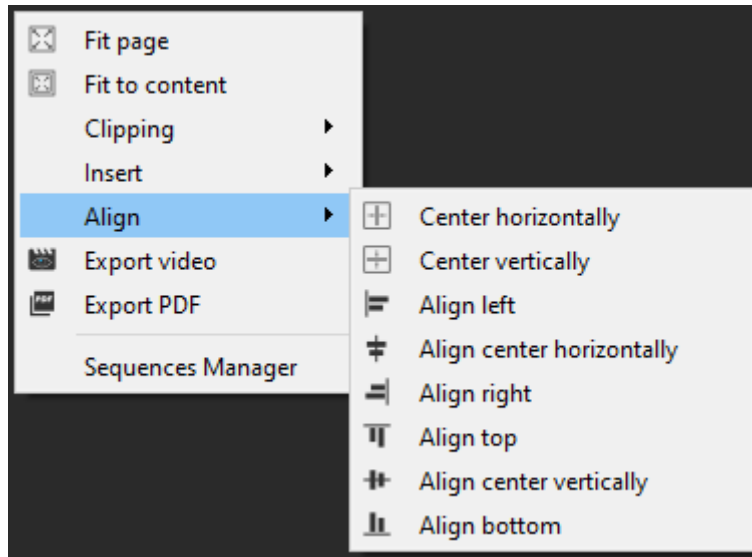

Figure 13.4: Detail of Align submenu.

- **Center horizontally** - Centers the selected objects horizontally with respect to the page
- **Center vertically** - Centers the selected objects vertically with respect to the page
- **Align left** - Aligns the left side of the selected objects
- **Align center horizontally** - Centers the selected objects horizontally with each other
- **Align right** - Aligns the right side of the selected objects
- **Align top** - Aligns the top side of the selected objects
- **Align center vertically** - Centers the selected objects vertically with each other
- **Align bottom** - Aligns the bottom side of the selected objects

13.1.2 Shortcut Keys in *iris*

Shortcut keys can be used to simplify common operations in *iris*.

- **Page Up**: Navigate to the previous page
- **Page Down**: Navigate to the next page
- **E**: Opens the *Export PDF* tool
- **V**: Opens the *Export Video* tool
- **</>**: Step forward or backward in timeline by the current time delta (default 0.1s). Alternate shortcuts are **,/.**
- **t/T**: Decrease/increase time delta for stepping through timeline
- **1**: Fits the current page to the workspace
- **2**: Fits the page contents to the workspace

- **#**: Toggles the workspace grid
- **Backspace/Delete**: Deletes items that have been selected
- **Cursor keys**: Move selected objects by 5mm (with *Shift*: 1mm, *Alt*: 0.5mm, *Shift+Alt*: 0.1mm).

i If pressing a shortcut key does not have any effect, the editor does not have keyboard focus. You can briefly zoom in and out with the wheel to give focus to the editor.

13.2 Pages, Templates and Backgrounds

The major elements of *iris* documents are **pages** and **backgrounds**. *iris* projects may also be made into **templates** for convenient reuse. These elements can be viewed and edited using the **page navigator** at the left of the workspace; the **page group pulldown** at the top may be used to select pages, templates, or backgrounds.

13.2.1 Pages

All elements in the *iris* editor are displayed on **Pages**. Through the use of multiple pages, elements like plots and images can be made to come and go from the document. All *iris* projects consist of one or more pages. Each page contains an independent set of elements and timelines.

To add, edit, and remove pages, right-click on the page in the page navigator to bring up the context menu seen in Fig. 13.5. Selecting “Page Up” or “Page Down” on the keyboard will allow users to quickly navigate through pages.

A single blank page may also be added by clicking the  icon in the toolbar.

Pages may be reordered by dragging them to the new desired position between two existing pages or before/after the first/last page.

- The **Preview size** submenu controls the appearance of the preview.
- Selecting **Hide** will minimize the page in the navigator.
- A new page can be created by selecting **Add empty page**.
- A new page can be added from an existing **template** by selecting **Insert template**.
- Selecting **Duplicate** will copy the selected page.
- Pages may be deleted by clicking **Delete page**.
- The background of the selected page may be chosen from the **Change background** submenu.
- The existing page may be copied for use in a **Template** or **Background**.

13.2.1.1 Transitions

Transition properties for individual pages may be accessed by selecting the page in the navigator and editing the **Page Transition** settings in the sidebar at the right of the workspace.

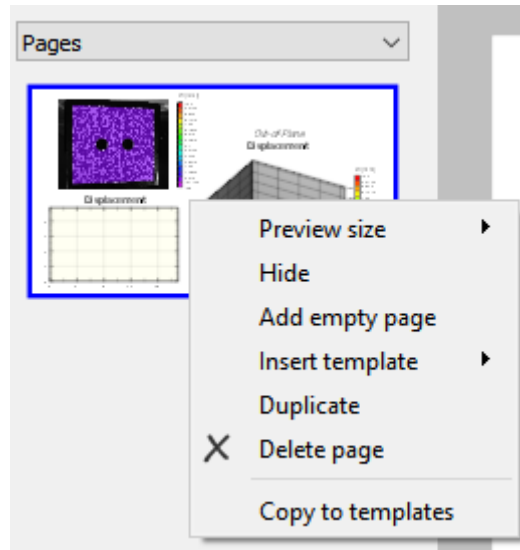

Figure 13.5: Pages context menu.

Default options for transitioning from one page to the next are accessed through the [Document Properties](#). The duration of an empty page may also be selected there; for non-blank pages, the duration ends after the last keyframe.

The time within the page (for preview display only) may be edited with the **Time** control in the right sidebar.

13.2.2 Templates

Templates are used to simplify reproduction of *iris* documents for new data. Right-click on the page in the template menu to bring up the context menu seen in Fig. 13.6.

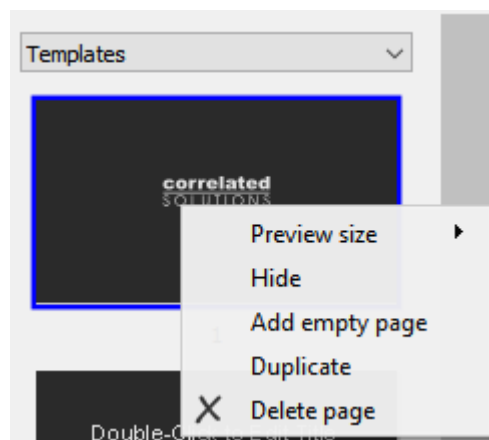



Figure 13.6: Template context menu.

To begin using templates, click the  icon on the main toolbar with no existing *iris* document to view the template chooser. For more information, see [Working with Templates](#).

13.2.3 Backgrounds

Backgrounds are fundamentally identical to [pages](#), except that they are static and do not have a timeline. Backgrounds can be used to give a consistent appearance to videos through headers, logos, background graphics, etc. Backgrounds may be manipulated by right-clicking on the background in the navigator to show the context menu, illustrated in Fig. 13.7.

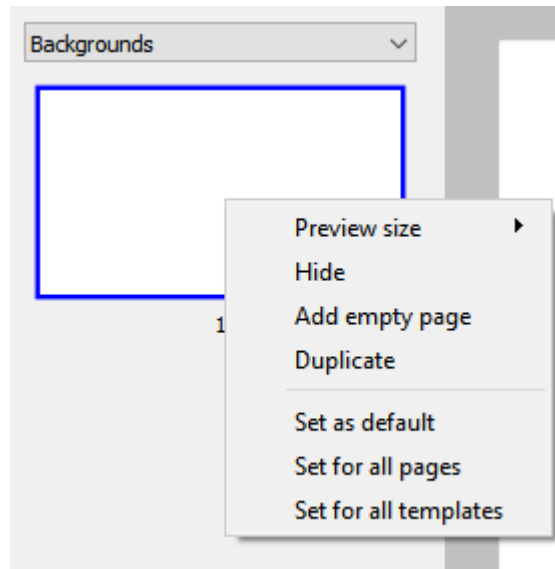

Figure 13.7: Background context menu.

Selecting **Set as default** will make the chosen background the default for new pages. To apply the selected background to all existing pages or template pages, select **Set for all pages** or **Set for all templates**.

13.2.4 Working with Templates

13.2.4.1 Using Templates

Templates in *iris* are used to enable easy reuse of *iris* projects for new data set. A page template is identical to a page and contains all of the same elements - plots, images, text, etc. A document template comprises a set of page templates and some or all of the page templates may be used. When a template is used with an existing Vic-3D project, many of the elements will be populated automatically, and captions and extraction plots may be easily filled in.

When no *iris* project is present, entering the *iris* workspace will show the **Template Chooser** shown below in Fig. 13.8.

User template documents are stored in a subfolder of the user's Documents folder; both built-in templates and all templates found there will be displayed in the chooser. A template may be selected here or **Empty document** may be clicked to start a new blank project.

Alternately, selecting **New iris document from template** from the **Iris Tools** menu will replace the current document with a blank document based on the selected template.

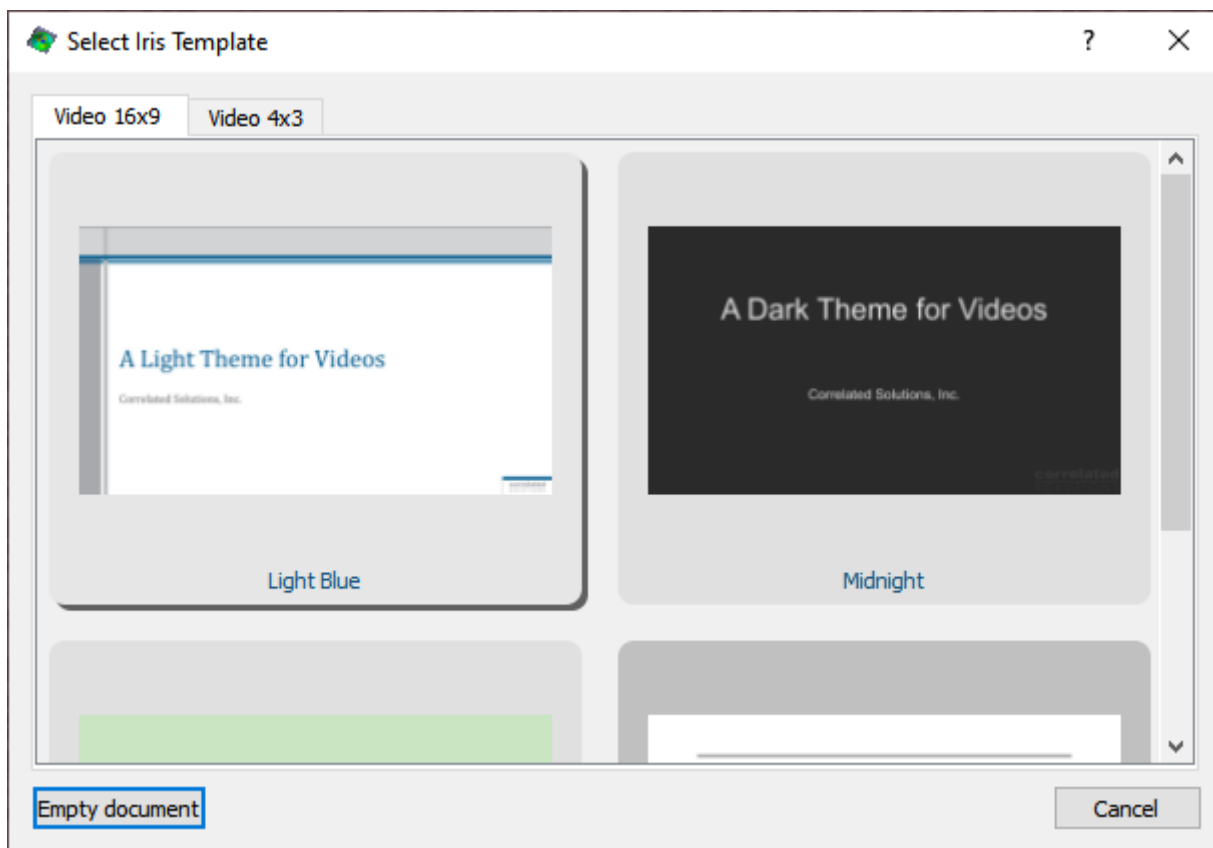



Figure 13.8: Template chooser.

Once a template document is chosen, the templates from the document will be displayed under **Templates** in the navigator view at left. The navigator pane is shown in Fig. 13.9.

To use templates, right-click in the **Pages** navigator at left to bring up the pages context menu shown in Fig. 13.10.

Selecting **Insert template** displays a submenu of available templates shown in Fig. 13.11. Clicking a template will cause it to be added as a page.

- Any plots are filled with existing data.
- For extraction plots, an existing extraction must be chosen from the plot [properties](#).
- Text boxes designated as template (see below) will be displayed as blank unless edited.

Multiple pages may be inserted by holding the  icon in the toolbar, this selection is shown in Fig. 13.12.

Single-clicking on a thumbnail will add it to the document; pressing Escape or clicking outside the menu will close it.

13.2.4.2 Creating Templates

A new template may be created by right-clicking in the Templates navigator, shown in Fig. 13.13.

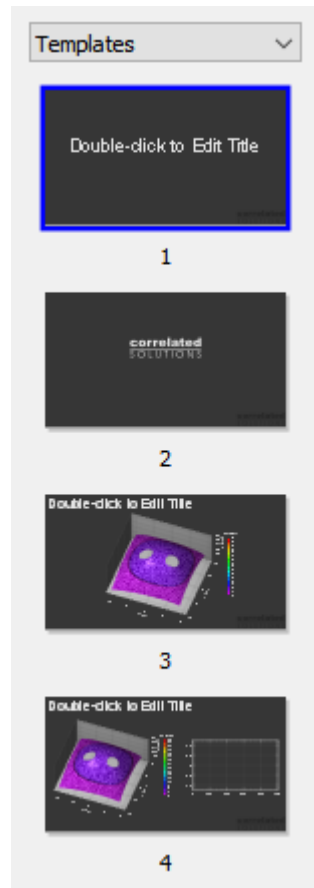

Figure 13.9: Template navigator.

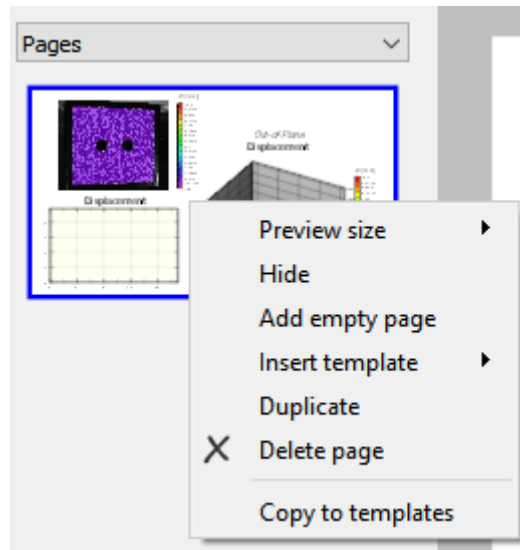

Figure 13.10: Context menu for pages.

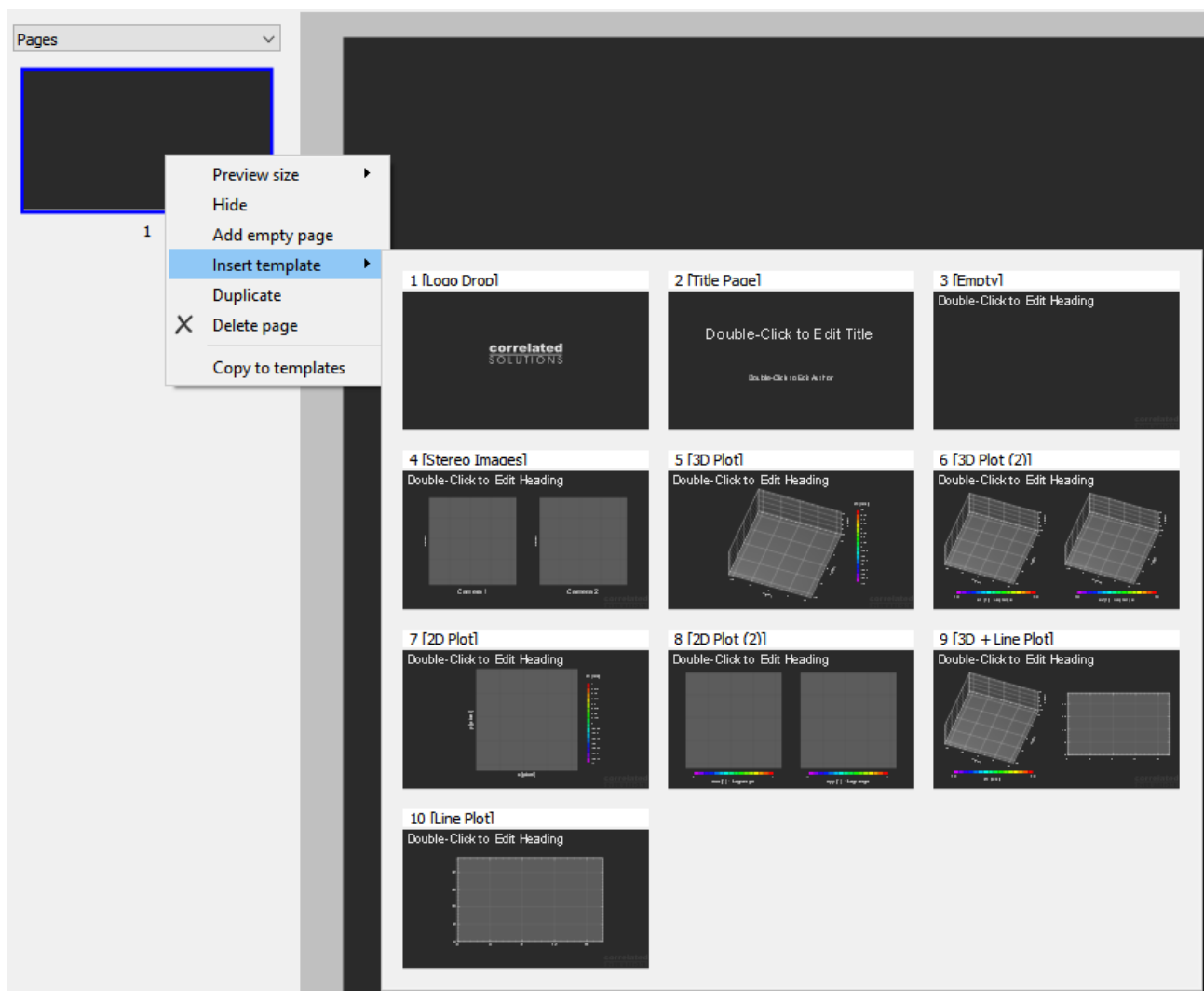

Figure 13.11: Context menu showing templates.

The template may be given a descriptive name using the **Name** field in the **Base** tools, shown in Fig. 13.14.

Editing templates is functionally identical to editing pages in most cases. For text boxes, the toolbar will contain a **Use as template** checkbox which can be seen in Fig. 13.15.

When this box is checked, the entered text becomes a placeholder, and the text will not be included in *iris* output unless edited.



The placeholder text may be used for tips to the template user, e.g., “Double-click to edit Title” or “Enter sample ID here”.

To copy an existing page for reuse as a template, right-click on the page in the **Pages**

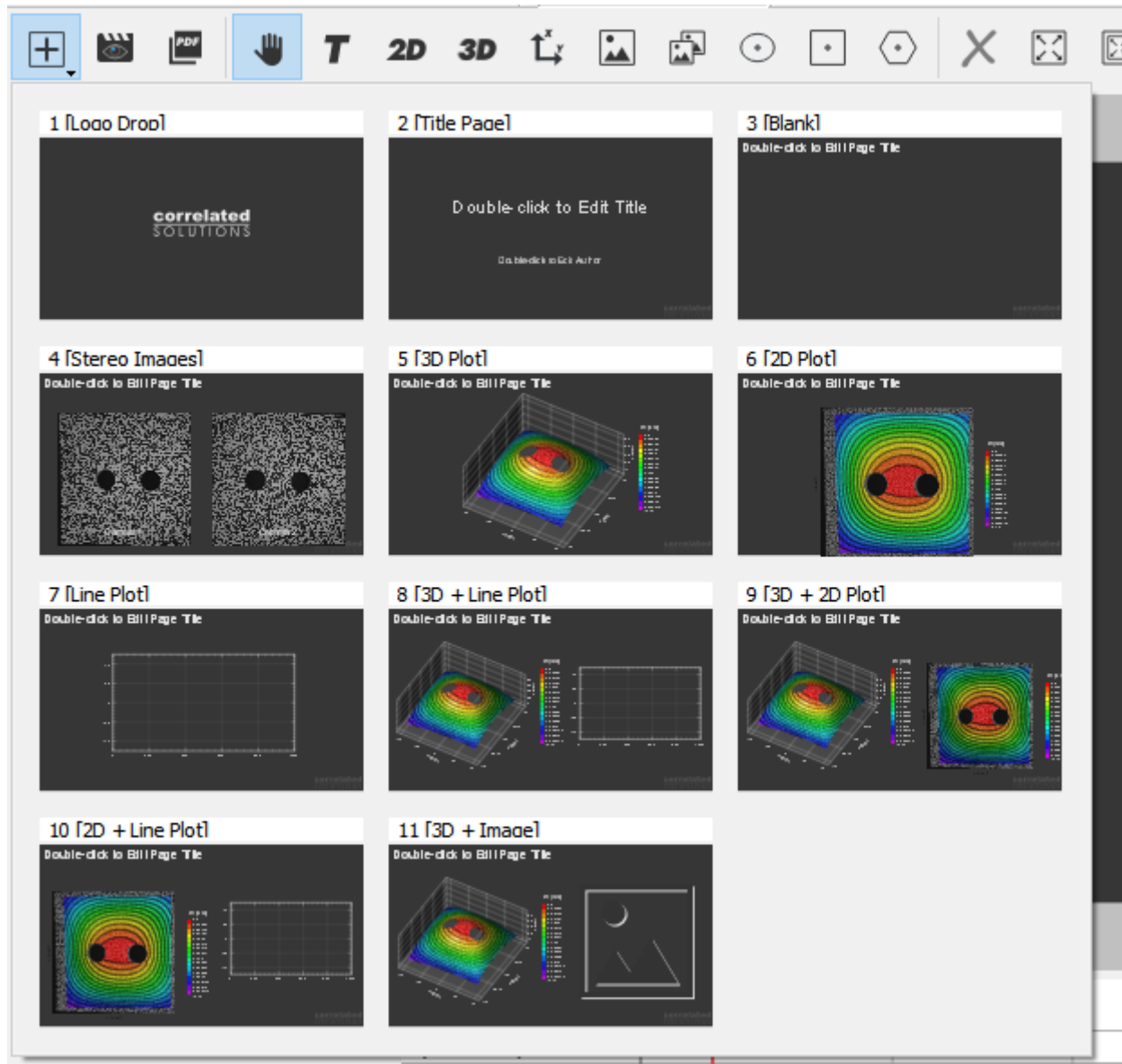

Figure 13.12: Multiple template selection.

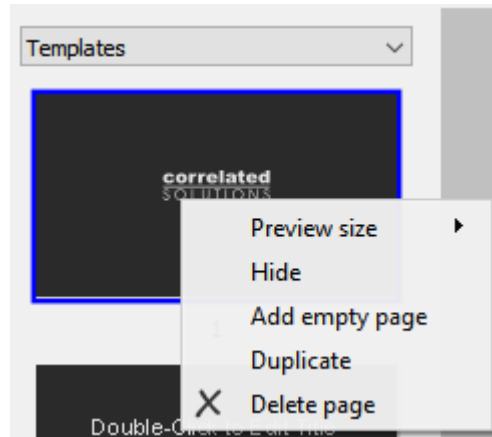

Figure 13.13: Context menu for templates.

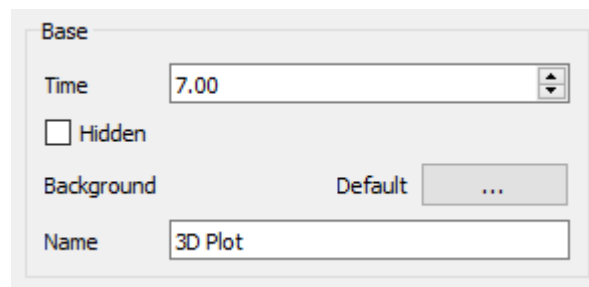

Figure 13.14: Template base tools.

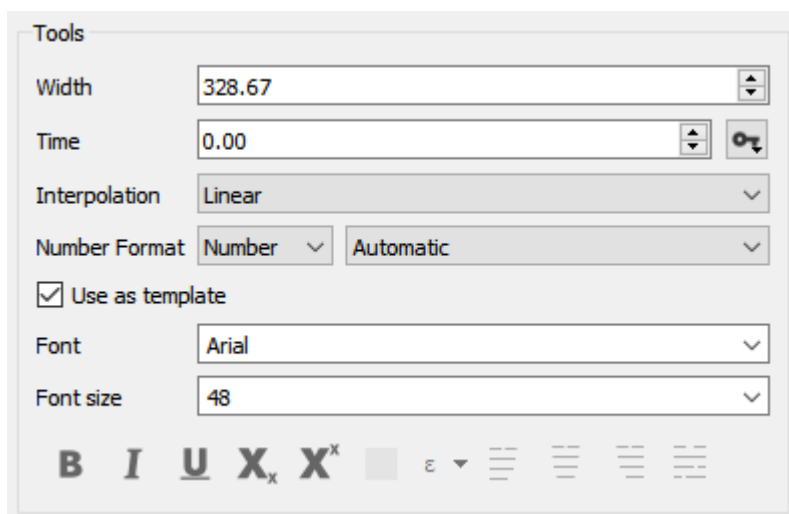

Figure 13.15: Template text tool.

navigator and select **Copy to templates**. The page is added to the template navigator and can then be chosen within the project.

To save the templates from a project as a reusable template file, select **Save as iris template** from the **Iris Tools** menu.



Templates should be saved in the folder chosen by *iris* for easy access from the Template Chooser.

13.3 Graphic Elements

Each page in an *iris* document comprises multiple graphical elements. Elements like drawings and plots can be placed on the page and optionally animated using **keyframes**. The following elements may be added to an *iris* document by clicking in the main toolbar or clicking the *Iris Tools* menu:

- **2D plots**
- **3D plots**
- **Image sequences**
- **Extraction plots**
- **Text boxes**
- **Static images and masks**
- **Mesh data sequences**
- **Ellipses, rectangles and polylines**

13.3.1 Element Properties

For placement, an element may be clicked once, which will cause it to be surrounded by a black border. This indicates it may then be clicked and dragged within the page. For editing, an element may be double-clicked which will show a red border. The element is then ready for editing (text editing, changing the angle of a 3D plot, etc.)

13.3.2 Common Properties

Many of the document elements in *iris* use a shared set of common tools. Common properties include things like base size, data sources, times, and axis controls. The following common tools are seen in *iris*:

- The **Base** tool controls positioning, alignment, scale, rotation, and depth.
- The **Data** tool controls data sources, time, and interpolation.
- The **Legend** tool sets contour variables and settings and legend settings and fonts.
- The **Variable** tool allows control of data sources and extractions.
- The **Axis** tool controls placement, format, and style of the x- and y-axes on various plots.

13.3.3 2D Plots

To insert a 2D plot in *iris*, click the **2D** icon, and then click once in the document workspace to insert a 2D plot box. The 2D plot can be edited by clicking on the image once to move the position of the entire plot and double clicking to move the image in the 2D plot window. Clicking on the 2D plot will also bring up the 2D plot properties, which can be adjusted in the sidebar.

13.3.3.1 Plot Properties

All properties of the inserted 2D plot are adjustable in the properties editor at the right side of the workspace. Properties are grouped into the following categories.

13.3.3.1.1 Data

The options for the 2D plot data are set using the common [data tool](#).

13.3.3.1.2 All

The **All** box shown in Fig. 13.16 allows users to adjust the visual appearance of the plot.

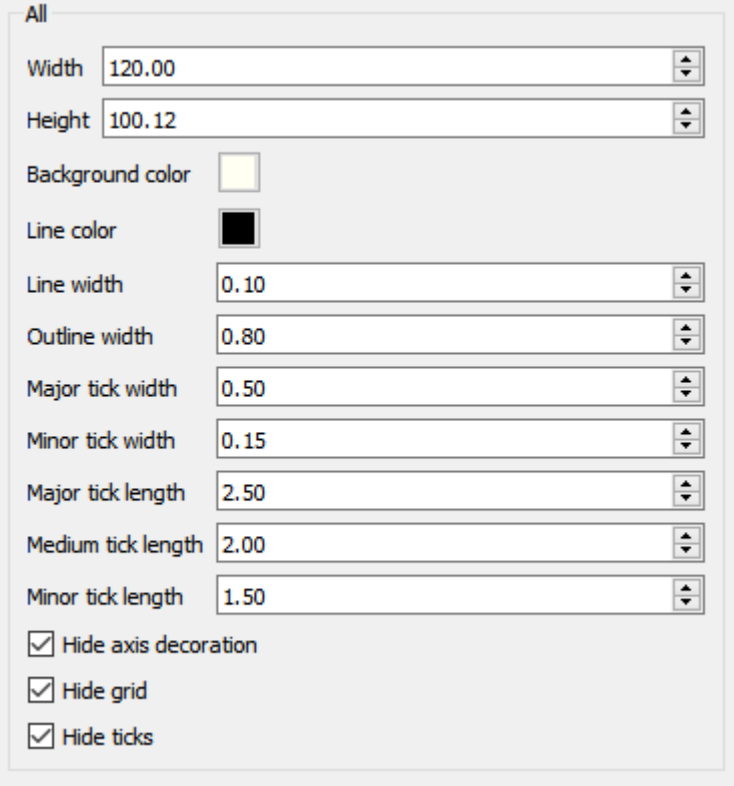

All	
Width	120.00
Height	100.12
Background color	
Line color	
Line width	0.10
Outline width	0.80
Major tick width	0.50
Minor tick width	0.15
Major tick length	2.50
Medium tick length	2.00
Minor tick length	1.50
<input checked="" type="checkbox"/> Hide axis decoration	
<input checked="" type="checkbox"/> Hide grid	
<input checked="" type="checkbox"/> Hide ticks	

Figure 13.16: All Tool in 2D Plot

The **width** and **height** set the overall width and height of the plot (not including the legend).

The **background color** will be shown anywhere in the plot area not occupied by plot data (if the range is larger than the plot).

The **line color** is the color used for all outlines and tick marks.

The tick length and width for major and minor ticks can be adjusted here; tick spacing is set the axis tools (see below).

Select **Hide axis decoration** to hide the displayed range values.

Hide grid hides the grid displayed in the background along major tick lines.

Hide ticks hides the plot outline and all tick marks.

13.3.3.1.3 X and Y-Axis

The 2D plot's X and Y-Axis properties can be set by using the common x- and y- [axis tools](#).

13.3.3.2 Plot Positioning

The position and rotation of the 2D plot are set using the common [base tool](#).

13.3.3.3 Legend Properties

The 2D legend properties can be adjusted from the sidebar by selecting the legend attached with the plot and using the common [legend tool](#).

13.3.4 3D Plots

To insert a 3D plot in *iris*, click the **3D** icon, and then click once in the document workspace to insert a 2D plot box. The 3D plot can be edited by clicking on the image once to move the position of the entire plot and double clicking to move the image in the 3D plot window. Clicking on the 3D plot will also bring up the 3D plot properties, which can be adjusted in the sidebar.

13.3.4.1 Plot Properties

All properties of the inserted 3D plot are adjustable in the properties editor at the right side of the workspace. Properties are grouped into the following categories.

13.3.4.1.1 Data

The different options available for the 3D plot data are set using the common [data tool](#).

13.3.4.1.2 View

The view properties shown in Fig. 13.17 control the visual appearance of the 3D plot and axes.

Keyframe time can be adjusted using the **Time** control, with values ranging from 0 to 1.

If the data needs to be displayed at a time that lands between two sequential data sets, **Interpolation** will be used to calculate intermediate values. The control allows for linear interpolation as well as disabling interpolation (nearest neighbor). Interpolation is used for triangulated data (plots, VTK data) but not for images.

The overall size of the plot may be set with the **Size** control. Checking **Show coordinate system** will cause the axis planes and scales to be displayed; if **Show speckle image** is checked, the speckle pattern will appear as a texture on the surface.

View

Time

Interpolation

Size

Show coordinate system

α

β

γ

Tick font

Axis label font

Axis label color

Label margin

Axis margin

X range

Y range

Z range

Z-ratio

X tick marks

Y tick marks

Z tick marks

Axis color

Plane color

Ambient intensity

Diffuse intensity

Specular intensity

Figure 13.17: View Tool in 3D Plot

The rotation angles for the plot about the X, Y and Z axes are set with the α , β , and γ controls, respectively. They may also be set by double-clicking in the plot and then clicking and dragging. The rotation angles are [animatable](#).

The font for the numbers labeled on the axis is set with **Tick font** while the font for the axis value labels (X, Y, and Z) is set with the **Axis label font**. Colors for both are set with the **Axis label color**.

Positioning of axis and tick labels can be adjusted by setting the **Label margin**. Changing the **Axis margin** affects the distance between the boundaries of the plot and the axis planes.

The boundary ranges (minimum and maximum) for each axis are set with the **X range**, **Y range**, and **Z range** controls. The X and Y axis scales are locked; the Z axis has an independent scaling that may be set with the **Z-ratio**.

The number of ticks per axis is set by the **X tick marks**, **Y tick marks**, and **Z tick marks** controls. Colors may be chosen for the **Axis** (the grid marks displayed on the axis planes), **Plane** (the axis planes themselves), and the **Material**.

Lighting intensity may be adjusted for the **Ambient** source (the amount of light everywhere in the scene), the **Diffuse** source (a diffuse Light source pointed at the surface), and the **Specular** source (a direct light which creates shine on the surface).



The material color is only visible if the contour overlay and speckle image display are disabled. To view **only** the object without any overlaid data, disable the contour, speckle, isolines, and coordinate system.

13.3.4.2 Plot Positioning

The position and rotation of the 3D plot are set using the [base tool](#).

13.3.4.3 Legend Properties

The 3D legend properties can be adjusted from the sidebar by selecting the legend attached with the plot and using the [legend tool](#).

13.3.5 Image Sequences

To add a sequence of images, click the  icon on the main toolbar. Import an image sequence from any source to use in iris animations.

The image sequence properties are set using the [data tool](#) in the sidebar. Predefined image sources (speckle images, calibration images) may be selected; an arbitrary image list may be chosen by selecting **Add Image Sequence** from the **Iris Tools** menu, or by using the [sequence manager](#).

- i** If you are selecting images from a DIC experiment, only one camera's images should be added for a smooth sequence.

The size and appearance of the image sequence and axes are set using the shared **all tools**, while the position and rotation of the image sequence are set using the **base tool**.

The 2D plot's X and Y-Axis properties can be set by using the common x- and y- **axis tools**.

- i** The x/y axis display is off by default because an image sequence only contains pixel coordinates, not metric data.

13.3.6 Extraction Plots

An extraction plot may be added to an *iris* document by clicking the  icon, and then clicking once in the document workspace. Extractions available for plotting are listed under the **data panel**. The extraction plot can be edited by clicking on the image once to move the position of the entire plot and double clicking to move the image in the 2D plot window. Clicking on the extraction plot will also bring up the extraction plot properties, which can be adjusted in the sidebar.

13.3.6.1 Plot Properties

The extraction plot properties can be adjusted from the sidebar.

Each X/Y data pair shown in the plot will be listed in the *Charts* tool box, as seen in Fig. 13.18.

To select the variables for a new or an existing X/Y pair, the X/Y data source and variable can be selected from the drop-down menus below the list box. Available data sources are:

- **Average** corresponds to the average value from the entire data set.
- **P0, R0, C0**, etc. are the values corresponding to inspector tools (points, rectangles, circles etc).
- **Analog data** corresponds to CSV data added to the project. This is normally a file generated by Vic-Snap.

After the variables for X or Y have been selected from the menus, the apply button on the right must be pressed to apply the changes. Note that the change applies to all X/Y pairs selected in the list box.

To delete an X/Y pair, the item must first be selected in the list box, followed by pressing the **Delete** button.

To add multiple X/Y pairs, select the **Multi...** button. Once selected, the *Options for New Plots* dialog will appear with selectable options and extraction objects, shown in Fig. 13.19.

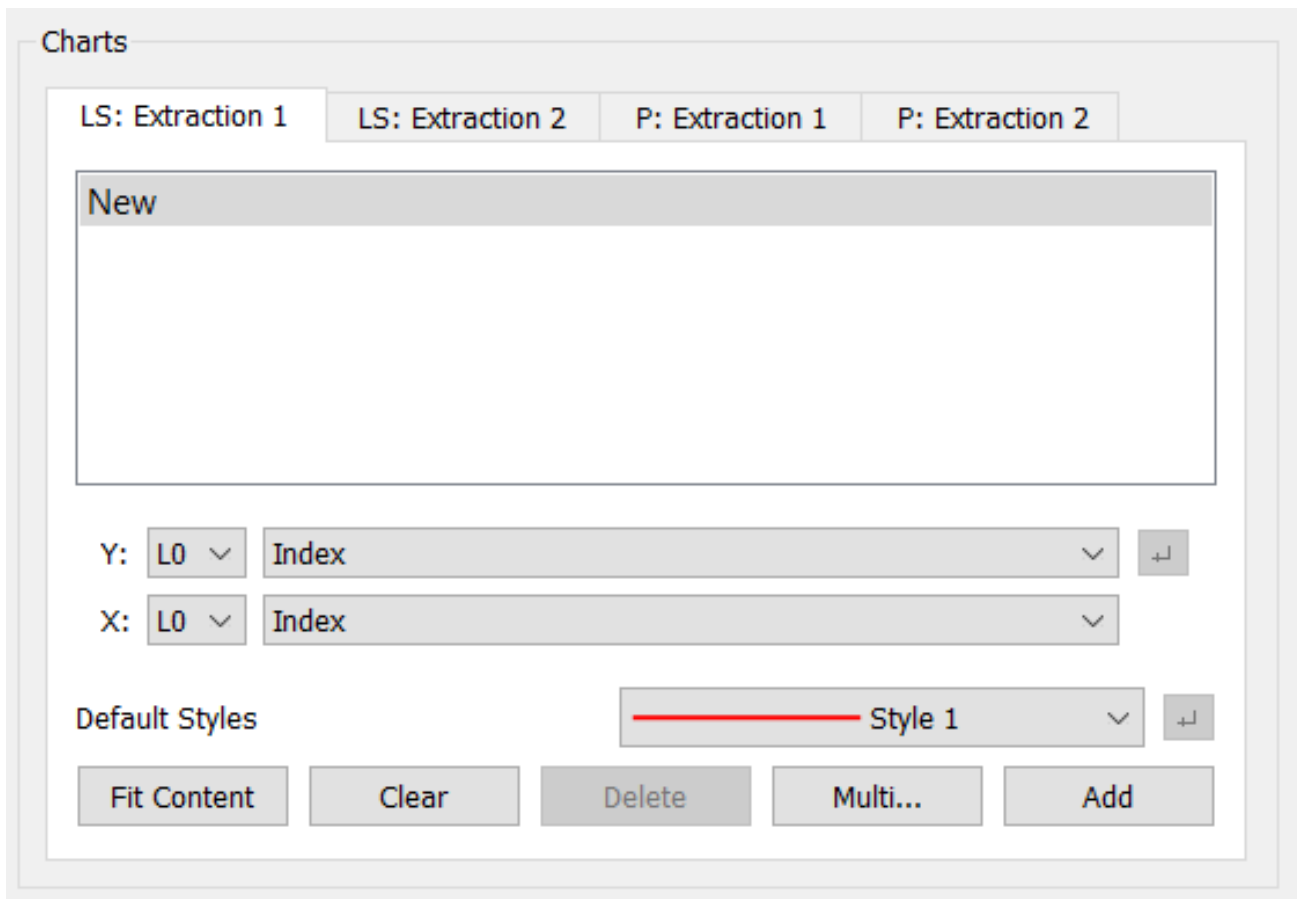

Figure 13.18: Charts Tool Box

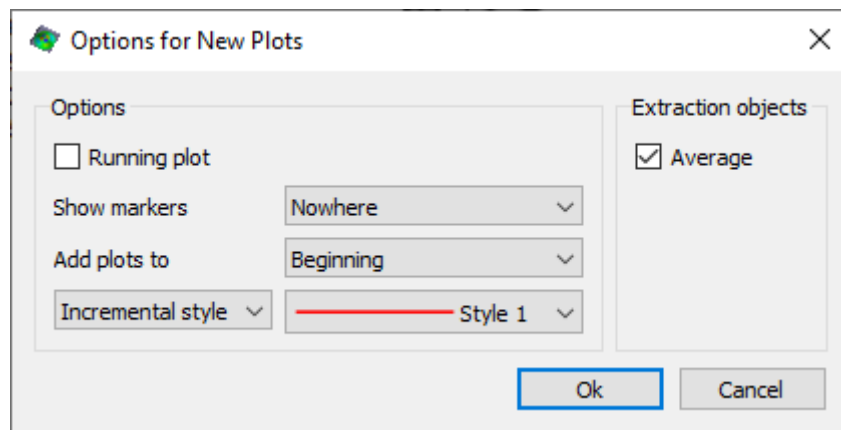

Figure 13.19: Multiple extraction options dialog.

New X/Y data pairs can be added to the plot by first selecting the *New* item in the list box at the top. Then, the data source and variables can be selected from the drop-down menus and the new X/Y pair is finally created by clicking the **Add** button.

Selecting an X/Y data pair plotted will expand the *Charts* window to customize the color, line style, line width, and markers placed, as seen in Fig. 13.20.

If **Automatic Name** is selected the name will be chosen based on the data; if this is cleared a name may be entered manually and edited with the style tools. If **Show in legend** is selected the name will also be displayed in the plot legend.

The **interpolation** control selects the interpolation (linear or nearest neighbor) used when the plot is animated.

Line and marker colors, size, and style may be edited with the associated **Line** and **Marker** tools. Markers may be disabled, shown everywhere, or shown only at the end of the plot. If **Running plot** is selected, the plot will be displayed up to the current **Time**, allowing the plot to be animated.

For line slice plots, additional time controls are displayed as shown in Fig. 13.21. If **Animate Graph** is checked the graph time will be the time selected or animated via the **all tools**. If this box is cleared, the plot will be displayed for the static time selected in **Graph time**.

13.3.6.2 Plot Legends

A plot legend may be added to allow easy identification of different data series. The legend tools are shown in Fig. 13.22.

Display of the legend is controlled by the **Show Legend** checkbox. The base position and location may be selected with the **Corner** and **Position along axis** tools; fine adjustments to this position can be made with the **Axis offset** controls. Border appearance and style, margins, fonts, and colors may all also be adjusted here.



The default color for the legend background has an Alpha (opacity) of 0. To make the background color visible, increase the Alpha value in the color chooser. An Alpha value of 255 corresponds to fully opaque.

13.3.6.3 All

The height and width of the extraction plot within the plot window as well as the appearance of the plot and axes are controlled with the shared **all tools**.

13.3.6.4 X and Y-Axis

The 2D plot X and Y-Axis properties can be set by using the **x and y-axis tool**.

13.3.6.5 Plot Positioning

The position and rotation of the 2D plot are set using the **base tool**.

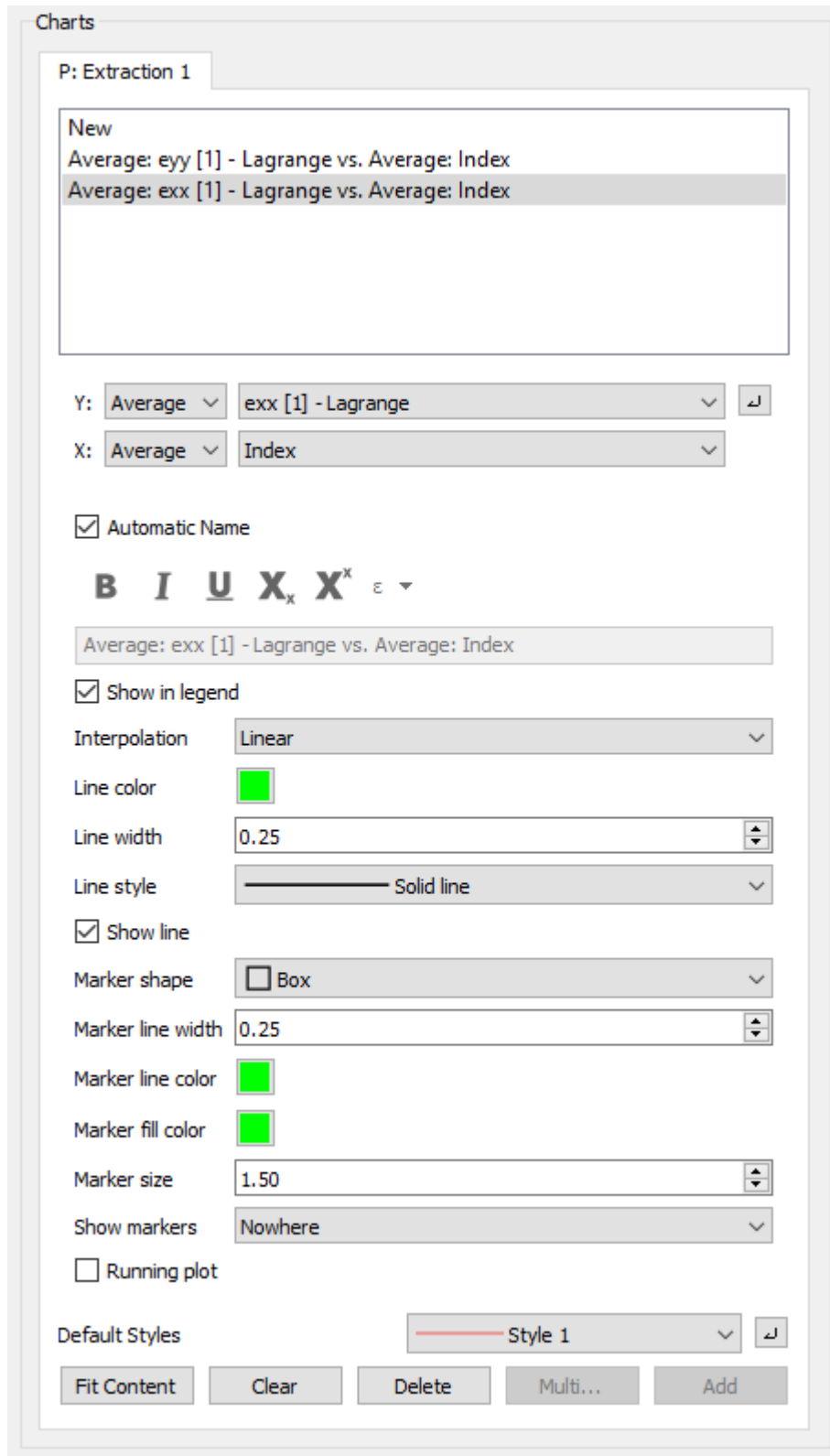

Figure 13.20: Chart style tools.

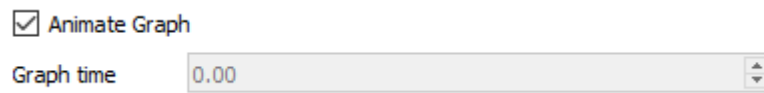

Figure 13.21: Line slice time tools.

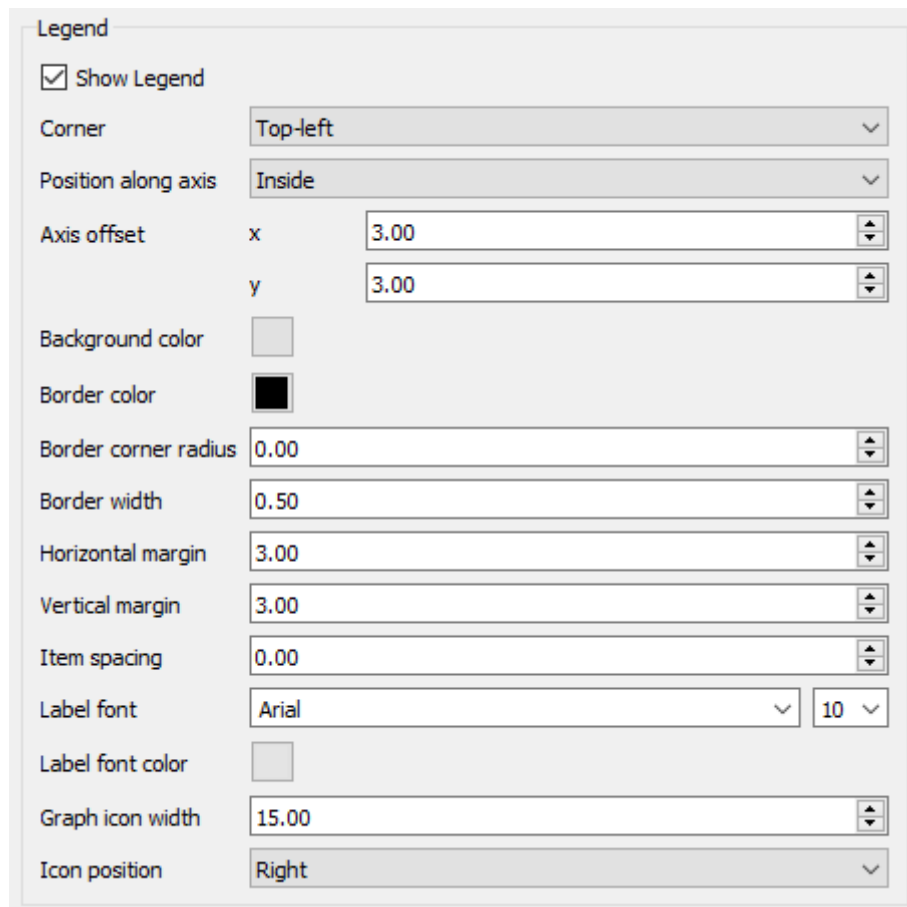

Figure 13.22: Plot legend tools.

13.3.7 Text Boxes

Text boxes can be used to add captions, titles, information, and extracted data values to an *iris* document. To insert a text box in *iris*, click the **T** icon, and then click once in the document workspace to insert a standard box.

13.3.7.1 Text editing

The text may then be edited by double clicking on the text box. Entering a ‘#’ at the beginning of a line will automatically create a numbered list. Entering ‘-’ or ‘*’ at the beginning of a line will automatically create a bullet list.

13.3.7.2 Text box tools

Text box properties may be adjusted using the sidebar tools, as shown in Fig. 13.23.

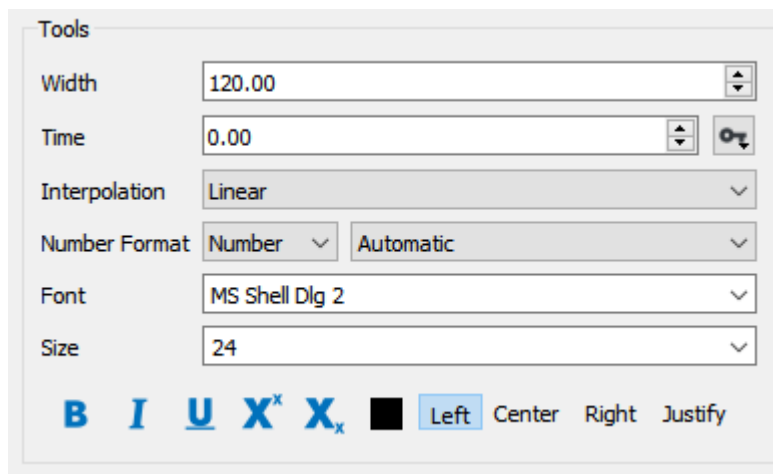

Figure 13.23: Text box tools.

The width and font size can be adjusted here, as well as the text justification.

i Select text within the box by holding Shift and using the arrow keys. When text is selected, font and style options will apply to selected text only; when no text is selected, the entire text box will be modified.

The Time control refers to the position within the data, when numerical data is present. The time control is [animatable](#).

13.3.7.3 Inserting data

To display numeric data in the text box, at least one extraction must be present in the project. You can insert the data at any location within your text by typing $\${n}$, replacing n with the index of your desired data source. Text box variables without data shown below in Fig. 13.24.

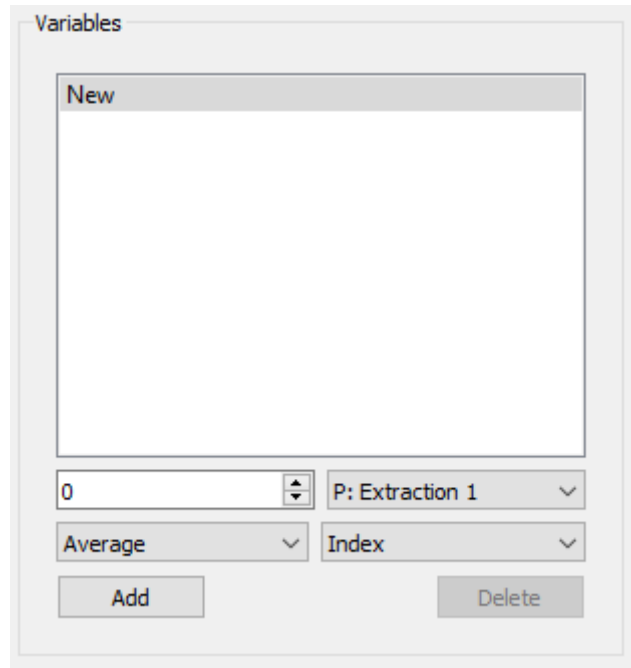

Figure 13.24: Text box variables.

Select the extraction from the pulldown, and then choose variables and click **Add** to add a data source, shown below in Fig. 13.25.

The data can now be referenced within the text by typing $\${0}$ or $\${1}$.

13.3.7.4 Text box positioning

The position and rotation of the text box are set using the [base tool](#).



13.3.8 Static Images

To add a static image, click the  icon on the main toolbar.

The position and rotation of the image sequence are set using the [base tool](#) and are [animatable](#). The View control at right sets the base size of the image in the workspace.

13.3.9 Drawing Tools

Simple graphical elements can be added using the drawing tools in *iris*. Ellipses, polylines, arbitrary polygons, rectangles, and rounded rectangles may be placed and animated as desired. These elements can also be used for clipping.

- To add an ellipse or rectangle, click the  or  icon in the main toolbar. Click and then drag in the workspace to draw the shape. Properties can be adjusted with the View tool in the toolbar shown in Fig. 13.26.

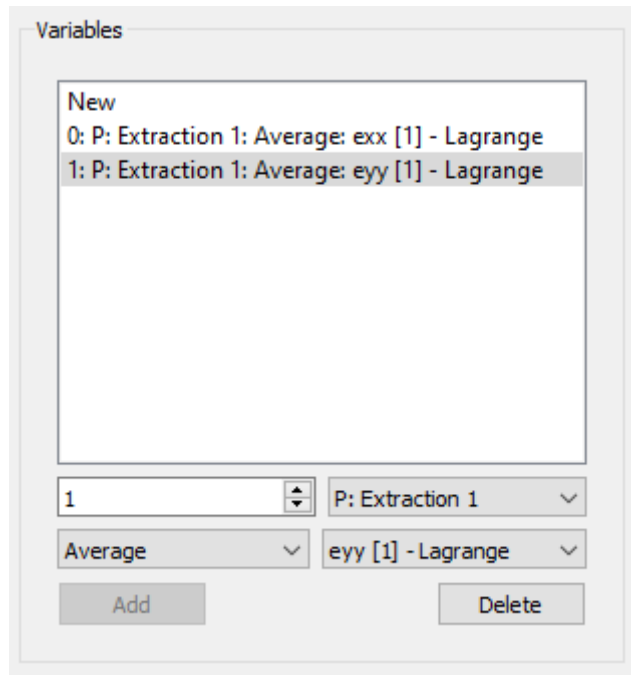

Figure 13.25: Text box variables, with data.

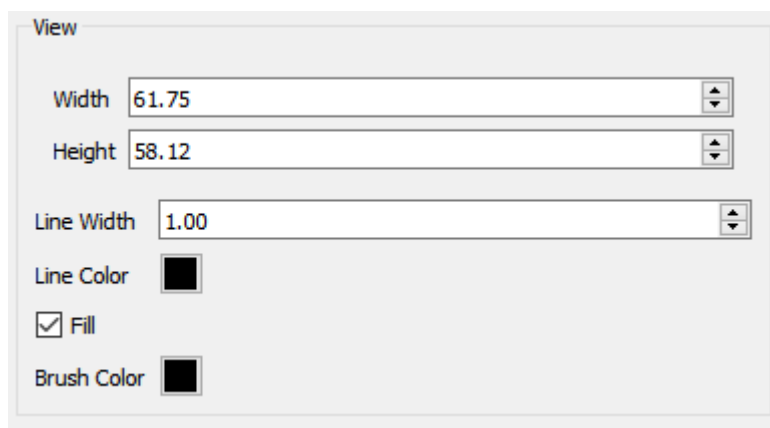

Figure 13.26: The view tool for an ellipse.

- Rectangles give one additional option for rounded corners, allowing you to adjust the radius shown in Fig. 13.27.

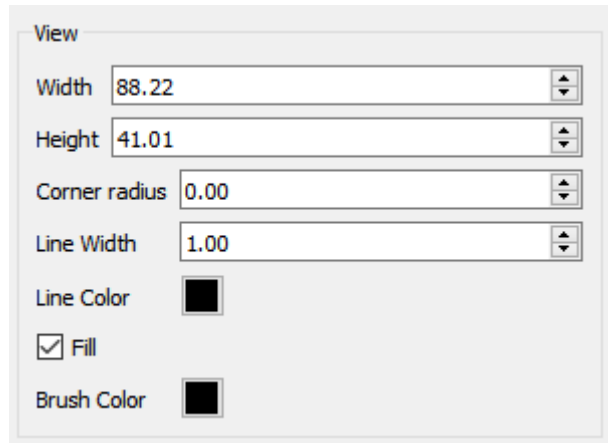



Figure 13.27: The view tool for a rectangle.

The **Line Color** controls the color of the outline; the **Brush Color** controls the fill color. The thickness of the outline is controlled by the **Line Width**.

- To add a polyline or polygon, click the  icon. Click once in the workspace to define the first point; click additional points to add, and then double click to finish. Properties are adjusted with the View tool shown in Fig. 13.28.

To force the polyline segment to 45 degree angles, hold Shift while drawing.

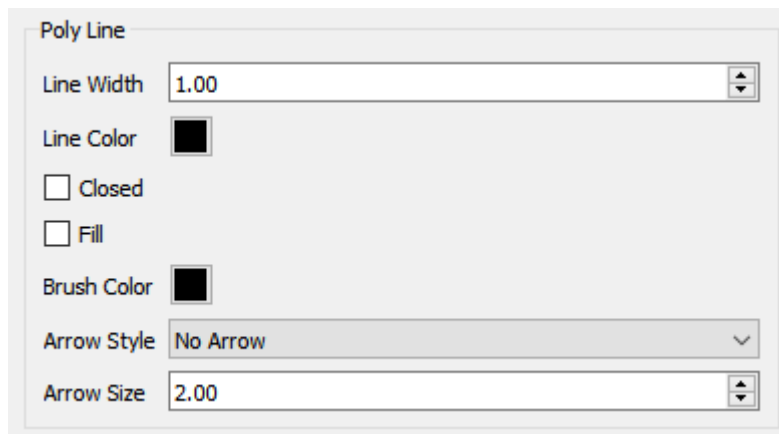

Figure 13.28: The view tool for a polyline.

A polygon may be created by selecting **Closed** to join the first and last point. Checking the **Fill** box will cause the interior area of the polyline to be filled with the **brush color**. An arrow style and size may also be selected.

13.3.10 Clipping *iris* Objects

- Using the ellipse or rectangle drawing tool, easily clip any *iris* objects simply by drawing a shape over the area within the object to be clipped, selecting the objects and the drawn shape, and then pressing “C” on the keyboard. Selecting any clipped objects and pressing shift + “C” will unclip the objects. Objects can also be clipped by using the context menu shown in Fig. 13.29 when right clicking on two selected objects.

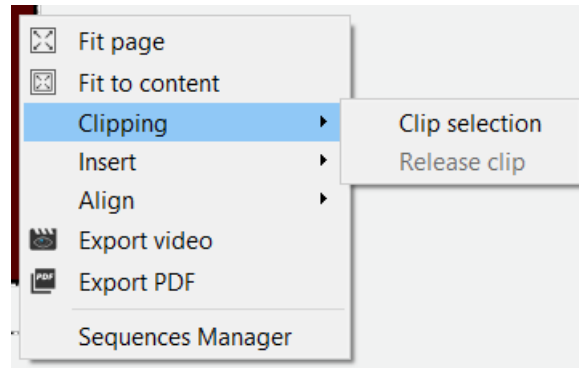

Figure 13.29: The context menu for clipping.

- The before and after effect of clipping can be seen in Fig. 13.30 and Fig. 13.31.
- When clipping objects the scale and the position are [animatable](#).

i The clipped object can be animated to show or hide objects as well as bring focus to certain areas within a 3D plot.

13.3.11 The Base Tool

Each element in *iris* shares a common set of controls for location, rotation, scale, etc. These control the placement and size of the object on the page and can be animated to allow motion, rotation, and zooming. These controls are contained within the **Base** tool, shown in Fig. 13.32.

The **x** and **y** controls set the object location within the page.

The **Rotation tool** adjusts the rotation angle of the object, in degrees.

The **Scale** tool scales the object, using the object’s Width and Height settings as a base.

The **Depth** controls the z-order within the page, determining which objects are displayed on top of others.

The **Opacity** control allows objects or background to be seen through the selected object, if set to less than 1.00. For a fully transparent (invisible) object the value should be set to 0.00.

The **Origin** controls are used to set the origin of the local coordinate system of the element. This is the fixed anchor within the element position, rotation, and scaling. Note that changing

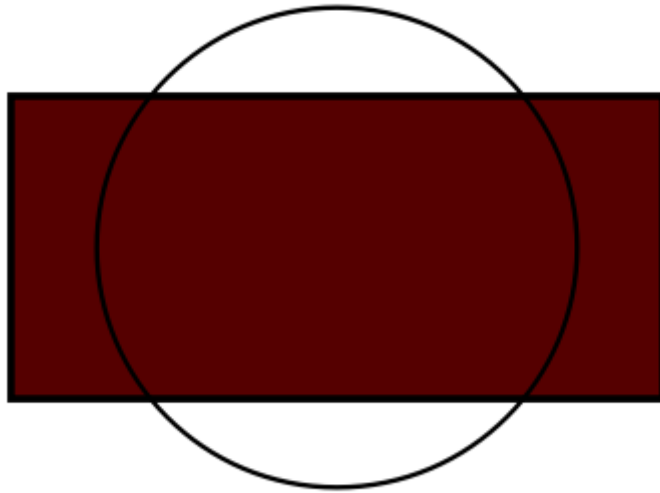

Figure 13.30: Rectangle and ellipse before clipping.

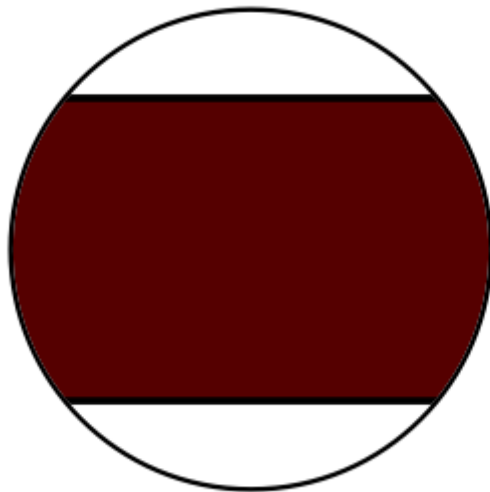

Figure 13.31: Rectangle and ellipse after clipping.

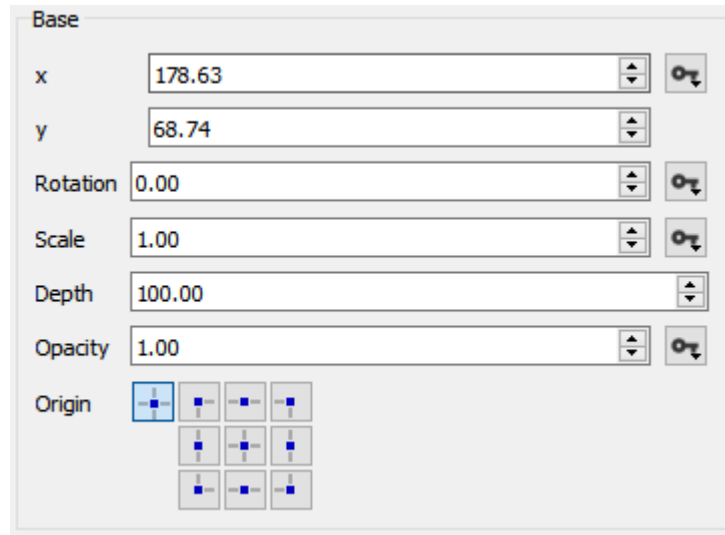

Figure 13.32: Base tool.

the origin will result in a movement of the object and it is recommended to set the origin before any animation of the object position is created. The default origin is different from the top-left corner for some objects. For instance, 3D plots use the center of the plot as the default origin to facilitate smooth interactive rotation of the plot.

All properties except depth and origin may be [animated](#).

i Since the **Depth** control is not animatable, [clipping](#) of an element may be used to allow elements behind it to be seen in an animation

i For templates to work well with different data and images, it is best to set the object origin to *center* on the template pages before positioning the object. This ensures that the object remain in a reasonable position when the template is applied to different data with, e.g., different image aspect ratios or data ranges.

13.3.12 The Data Tool

In *iris* various elements are based on sequential, time-based data. Image sequences, VTK data sequences, text boxes containing values, and contour plots all have a time element.

Depending on the data source, the data tool will have different options available. Below, the 3D triangulated data plot menu is shown in Fig. 13.33, the 2D triangulated data plot menu is shown in Fig. 13.34, the 3D marker data plot menu is shown in Fig. 13.35, and the 2D marker data plot menu is shown in Fig. 13.36.

13.3.13 Data Tools for Triangulated Data

Triangulated data in *iris* refers to either correlated data (.OUT files) or to imported model data (VTP data).

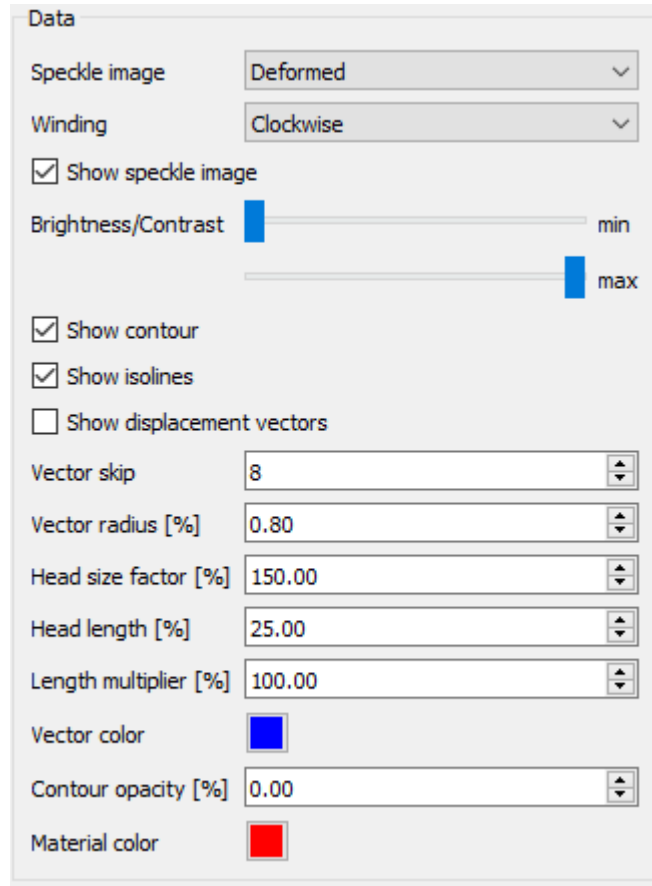

Figure 13.33: Data tool for 3D plot of triangulated data.

For 2D and 3D plots, a **Speckle image** can be selected. Either the deformed or reference speckle pattern may be chosen as a texture.

For 3D plots, a **Winding** control allows selection of clockwise or counterclockwise mesh winding, or winding direction may be ignored.

i Winding refers to the direction in which faces are defined and is used to determine the illuminated face. Vic-3D data and most mesh data is clockwise wound. If the direction is unknown, selecting Ignore usually gives a good result.

Show speckle image displays the speckle image along with the contour variable, unchecking this will show only the color gradient. The **Brightness/Contrast** slider allows you to adjust the top slider to control the minimum brightness, and the bottom slider to adjust the minimum

and maximum grey values. **Show contour** enables or disables the contour variable on the 3D plot. **Show isolines** enables or disables isolines on the 3D plot, individual isoline settings are found under the **Legend**.

Show displacement vectors enables or disables displacement vectors on the 3D plot. **Vector skip**, **Vector radius**, **Head size factor**, **Head length**, **Length multiplier**, and **vector color** are all settings specific to the visualization of vectors in *iris*. **Contour opacity** adjusts the opacity levels of the contour variable on the 3D plot. **Material color** is the color of the 3D model if the contour variable and speckle image overlay is not enabled.

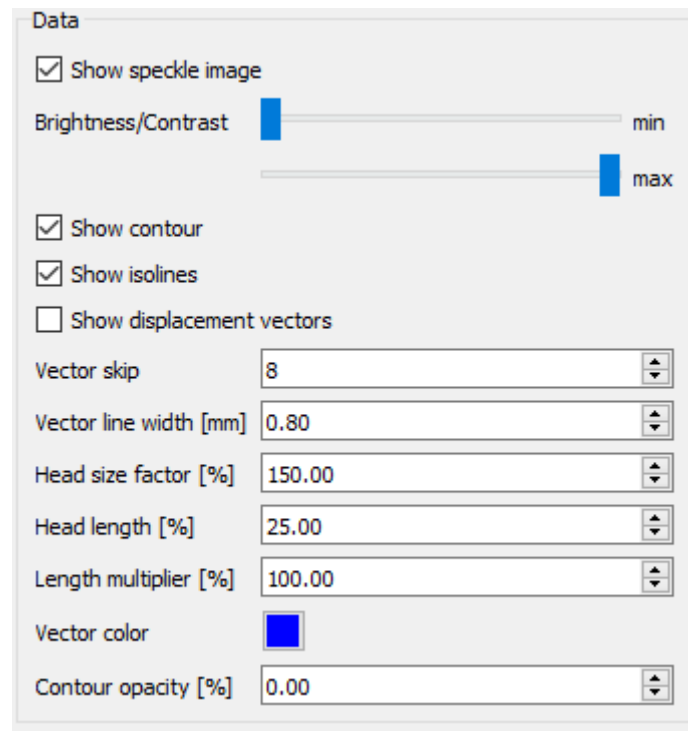

Figure 13.34: Data tool for 2D plot of triangulated data.

Show speckle image displays the speckle image along with the contour variable, unchecking this will show only the color gradient. The **Brightness/Contrast** slider allows you to adjust the top slider to control the minimum brightness, and the bottom slider to adjust the minimum and maximum grey values. **Show contour** enables or disables the contour variable on the 2D plot. **Show isolines** enables or disables isolines on the 2D plot, individual isoline settings are found under the **Legend**.

Show displacement vectors enables or disables displacement vectors on the 2D plot. **Vector skip**, **Vector radius**, **Head size factor**, **Head length**, **Length multiplier**, and **vector color** are all settings specific to the visualization of vectors in *iris*. **Contour opacity** adjusts the opacity levels of the contour variable on the 2D plot. **Material color** is the color of the 2D model if the contour variable and speckle image overlay is not enabled.

13.3.14 Data Tools for Marker Data

In *iris*, markers may represent either extracted markers (ellipse/bowtie), or plot extraction points. They are treated and displayed identically once in the *iris* workspace.

Properties for a single marker may be edited by selecting the marker in the **Markers** list and clicking **Edit**. This will display the [Marker Properties](#) dialog.

Show markers displays the markers on the ends of each connection. **Marker radius** adjusts the size of the markers on the ends of each connection. **Show markers contour** enables or disables the contour variable on markers. **Show connections** enables or disables the connections between the markers. **Show connection contour** enables or disables the contour variable on the connections between the markers. **Marker color** is the color of the 3D markers. **Connection color** is the color of the connection between the markers. **Connection radius** adjusts the size of the connection between the markers. **Number of tracers** adds phantom tracers in for the locations of the marker throughout time. **Tracer opacity and tracer cut-off time** adjust the opacity of tracers and the length of time they remain.

Show speckle image displays the speckle image along with the contour variable, unchecking this will show only the color gradient. The **Brightness/Contrast** slider allows you to adjust the top slider to control the minimum brightness, and the bottom slider to adjust the minimum and maximum grey values. **Show markers** displays the markers on the ends of each connection. **Marker radius** adjusts the size of the markers on the ends of each connection. **Show markers contour** enables or disables the contour variable on markers. **Show connections** enables or disables the connections between the markers. **Show connection contour** enables or disables the contour variable on the connections between the markers. **Marker color** is the color of the 2D markers. **Connection color** is the color of the connections between the markers. **Connection line width** adjusts the width of the connection between the markers.

The label number format and appearance may be adjusted using the Label controls. **Tracers**, **trajectory**, or both may be displayed. **Tracers** are an animatable and fading indication of the prior positions of the marker. The **Trajectory** indicates the path of the marker. To disable tracers/trajectory for a single marker, the [Marker Properties](#) dialog can be used.

13.3.14.1 Data source

- For 2D and 3D plots, the data source will be project data (.OUT) files, [triangulated marker data](#), and extraction points and data. The current project's data is selected by default. An arbitrary data set can be made available by choosing **Add Data Sequence** from the **Iris Tools** menu, or by using the or by using the [sequence manager](#). The new data will appear in the **Data source** pulldown.
- For image sequences, a sequence source can be chosen. The Speckle and Calibration image sets are always available. An arbitrary image set can be made available by choosing **Add Image Sequence** from the **Iris Tools** menu or by using the [sequence manager](#). The image set will then appear in the **Data source** pulldown.

When project speckle images are the data source, a **Camera Id** control appears to allow display of images from camera 0 or 1.

Data

Markers

Flywheel
 Piston Rod

Edit

Show markers

Marker radius [%] 2.00

Show marker contour

Show connections

Show connection contour

Marker color 

Connection color 

Connection radius [%] 1.00

Number of tracers/trajectory points 0

Tracer opacity 0.20

Tracer cut-off time 0.00

Show marker labels

Label Number Format Best Automatic

Label font MS Shell Dlg 2 10

Label font color 

Label background color 

Label boundary color 

Label boundary width 0.50

Label corner radius 0.00

Label offset x 0.00 y 3.00

Label margin 2.00

Tracers/Trajectory None

Trajectory radius [%] 1.00

Show trajectory contour

Trajectory color 

Figure 13.35: Data tool for 3D plot of marker data.

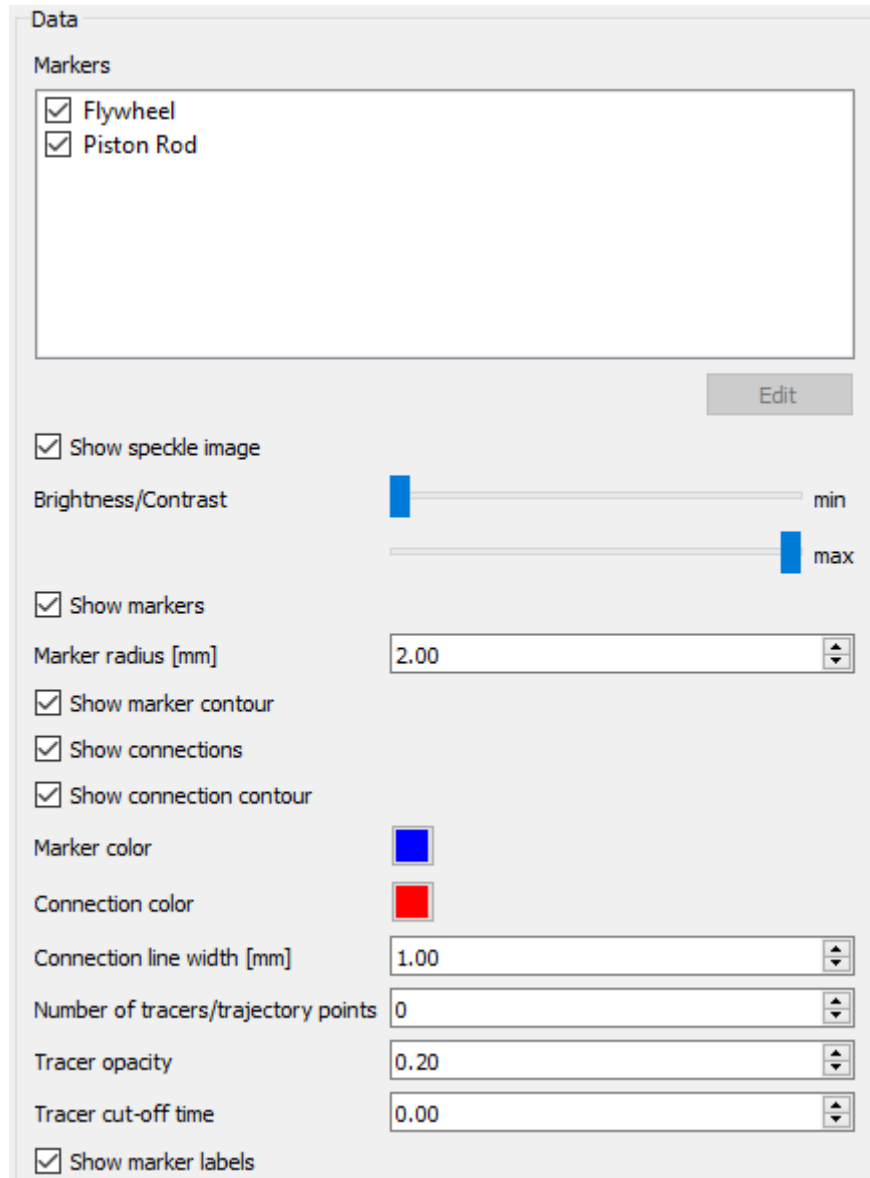

Figure 13.36: Data tool for 2D plot of marker data.

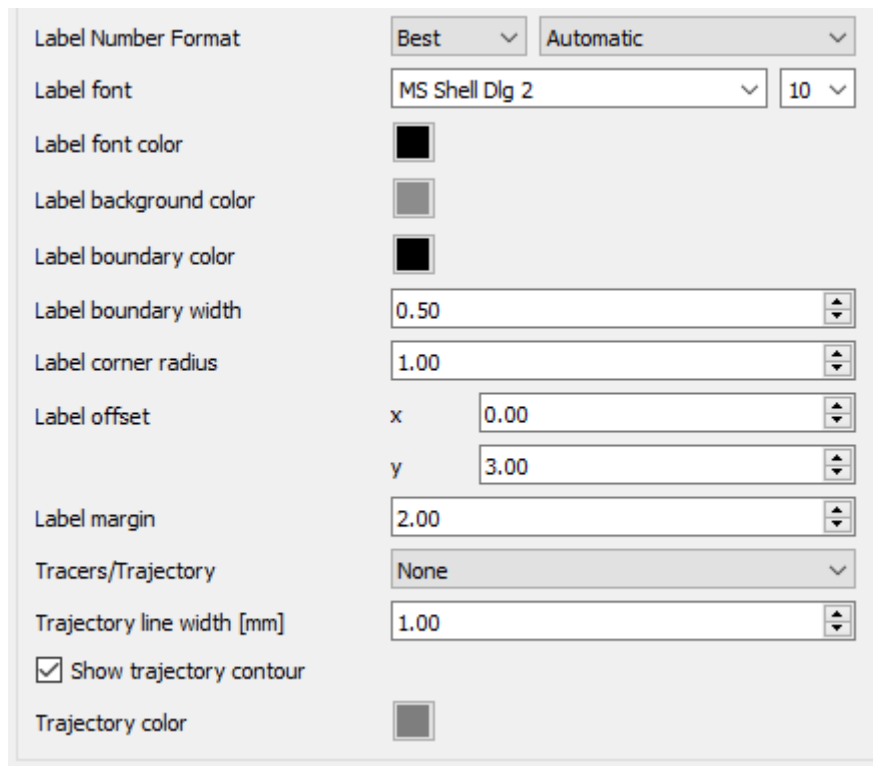

Figure 13.37: Data tool for 2D plot of marker data.

13.3.15 Marker Properties

The marker properties dialog is used to edit marker appearance and labels. It can be displayed by selecting a marker from the [data tool](#) and clicking Edit.

The marker color and radius may be adjusted using the controls at the top of the dialog. Checking **Show contour** will cause the marker to be colored in the contour color according to its value rather than the selected color. Checking **Enable tracers/trajectory** will enable the display of tracer and trajectory decorations for the marker; clearing the box will override the global settings in the Data Tool and hide decorations for this marker.

13.3.15.1 Text editing

The default label for the marker may be edited or overridden using the line editor. Standard tools are present for bold, italic, underline, sub/superscript, and Greek characters.

The default marker display is *marker name : marker value*. The formatting and displayed values may be changed, added, or removed. A list of possible escape codes is displayed at the bottom of the dialog; double-clicking will insert the appropriate code at the cursor position. During rendering, the code will be replaced with the evaluated value.

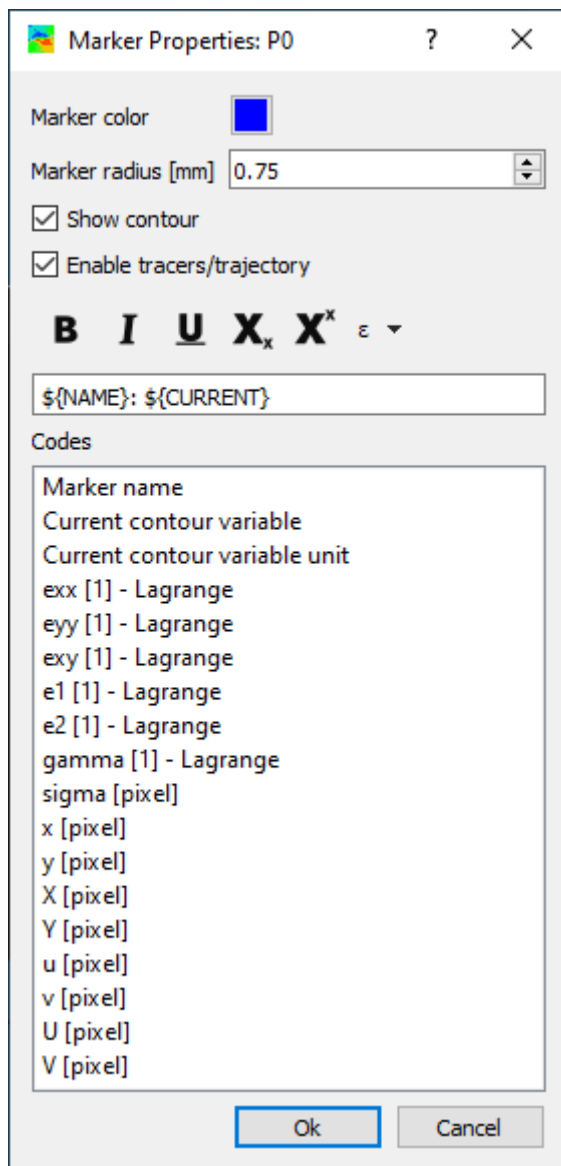

Figure 13.38: Marker properties dialog.

13.3.16 The Legend Tool

The legend tool controls the legend properties for both 2D and 3D plots in *iris*. This tool affects the legend itself and also contains controls for the appearance of the attached plot. A 2D legend is shown below in Fig. 13.39:

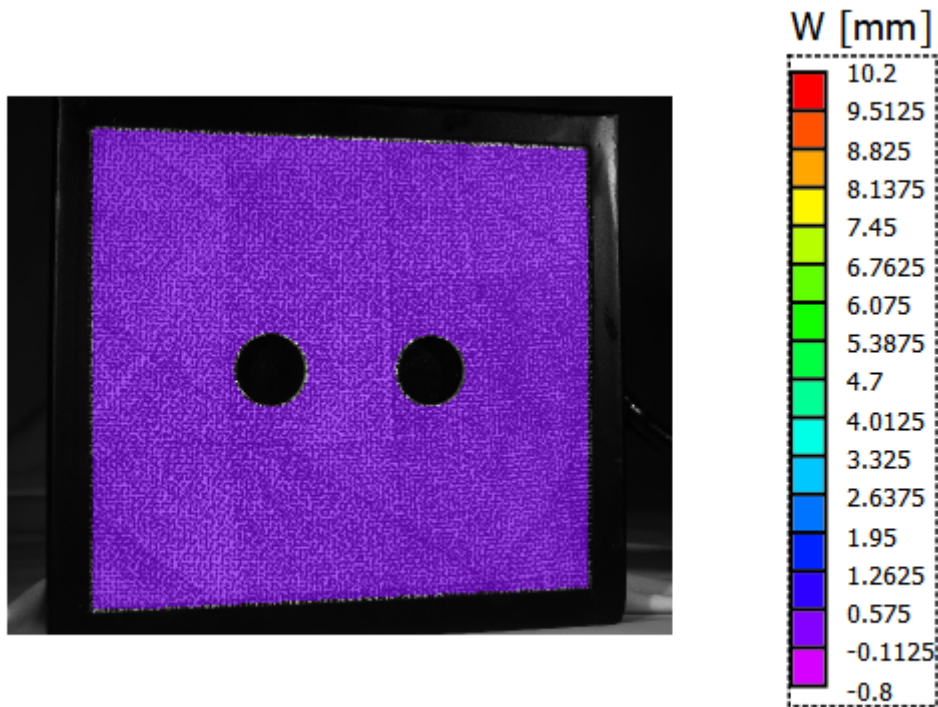

Figure 13.39: Plot with legend selected.

Clicking the relevant legend will highlight it with a black border; settings shown in Fig. 13.40 may then be edited using the toolbar at the right.

13.3.16.1 Legend Properties

Contour

The contour properties may be adjusted from the sidebar by selecting the legend attached to the plot.

The **Variable** pulldown determines which variable to overlay as a contour plot. The contour overlay may be hidden by clearing the **Show contour** box, and the isolines may be hidden by clearing the **Show isolines** box.

The range of contour variables (minimum and maximum) is set with the **Range** controls. The opacity of the overlay is set with the **Opacity** control; 0.00 is invisible and 1.00 is fully opaque.

A variety of color maps may be chosen from the **Color map** pulldown. The number of levels is set with the **Colors** control, and the number of isoline levels is set with the **Isolines** control.

Contour

Variable

Show contour

Show isolines

Range

Opacity

Color map

Colors

Isolines

Line color

Line width

Isoline color

Isoline width

Bar length

Bar width

Number format

Font

Font color

Base

x

y

Rotation

Scale

Depth

Opacity

Origin

Attach to

Orientation

Figure 13.40: Legend tool for 3D plot.

The **Line color** and **Line width** affect the appearance of the contour legend; the **Isoline color** and **Isoline width** control the appearance of the isolines. The size of the color scale bar is controlled by the **Bar length** and **Bar width**.

The format, color, and font of the contour legend labels are set with **Number format**, **Font**, and **Font color**.

Legend Positioning

The position and rotation of the legend are set using the [base tool](#).

i The contour variable name displayed near the chart is an editable [text box](#) and may contain variables, etc.

13.3.17 The Variable Tool

The variable tool shown in Fig. 13.41 controls the variable properties for both 2D and 3D plots in *iris*.

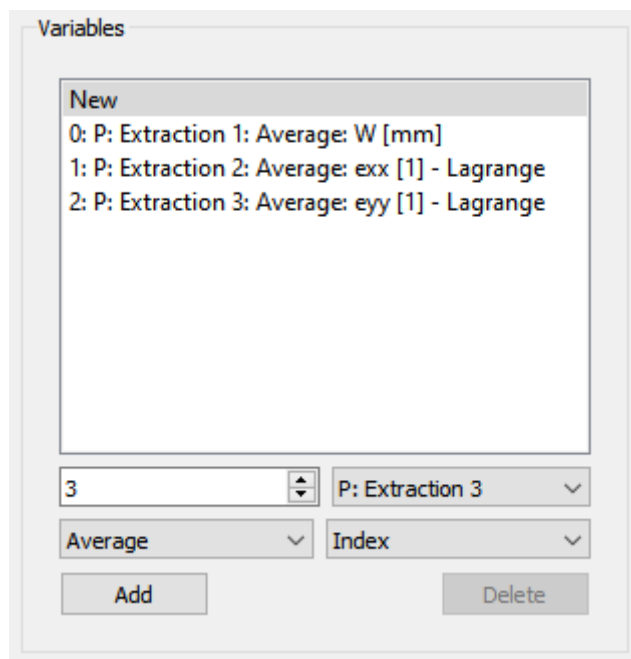

Figure 13.41: Variable tool for 3D plot.

The **Variable** tool allows users to add different variables from the extractions created in the 2D workspace. To add a new variable, first select the extraction plot of interest from the extraction drop down menu. Once selected, the data source drop down will be populated with inspect tools used in the extraction. Simply select the inspection tool of interest, the variable from the variable drop down menu, and select *Add*. The variables will then be available for use in the text box. To delete any unwanted variables, simply select the variable to remove and click *Delete*.

To call on a variable from the variable tool, double click the text box and replace the text with $\{\dots\}$, making sure to put the number corresponding with the variable being recalled from the variable tool. Once the text has been replaced, click outside the text box to confirm. The data from the called variable will now appear in the text box.



In order to add or use a variable in the variable tool, the user must first create an extraction in the 2D workspace.

13.3.18 The Axis Tool

In *iris*, 2D plots, images, and extractions have associated x- and y-axis ticks and labels. The placement, format, and style of these axes are controlled with a common **Axis** tool as shown in Fig. 13.42.

The **Range** control sets the axes ranges. For extraction plots, this will be in data units; for 2D plots, the value is in pixels.

To reverse the given axes, check **Invert axis**

The **Ticks label margin** adjusts the distance between the plot and the numbered tick labels.

The **Major ticks** and **Minor ticks** boxes control the number of major ticks for the entire range, and the number of minor ticks between each major tick.

The **Tick Font**, tick font size pulldown, and **Tick Font Color** controls affect the numbers displayed alongside each tick.

Formatting of numerical values is selected with the **Ticks Number Format** control; select Scientific notation, Number for positional notation, or Best to select based on data. Precision can be selected with the adjoining pulldown.

The **Label Position** pulldown allows top/bottom or left/right placement of the tick label depending on axis.

The **Label Alignment** pulldown allows the option of left, right, or center alignment for the label along the axis. The **Label Margin** control adjusts the margin between the numbered tick labels and the axis label.

Checking **Hide Label** hides the axis label.

IF **Automatic Label** is selected, the label will match the data. A custom label can be entered by clearing the checkbox and entering the text in the text edit at the bottom of the axis control.

The **Label Font**, font size pulldown, and **Label Font Color** controls affect the appearance of the associated axis label. Controls are also available for text formatting and symbol entry, when using a custom label.

13.4 Working with Sequences

All time-based data in *iris* is considered to be a **sequence**. Existing sequences can be viewed and edited by clicking **Sequences Manager** under the **Iris Tools** menu. The sequence manager

X Axis

Range: -27.8435
2435.16

Invert axis

Ticks label margin: 2.00

Major Ticks: 5

Minor Ticks: 4

Tick Font: Arial 12

Tick Font Color: [Black]

Ticks Number Format: Number Automatic

Label Position: Bottom

Label Alignment: Center

Label margin: 2.00

Hide Label

Automatic Label

Label Font: Arial 12

Label Font Color: [Black]

B I U X_x X^x ε

x [pixel]

Figure 13.42: X and Y Axis Tools.

can be seen below in Fig. 13.43.

Examples of sequence types include:

- Speckle and calibration images
- Triangulated data (output files, VTK data)
- Extraction data
- Image sequences
- Marker tracking data

Sequences may be added by selecting “New”. Once a sequence is added to the *iris* project, it may be selected as a data source for the relevant element (images for image sequences, triangulated data for 3D plots, etc.)

In cases where sequences have a differing number of frames (e.g., if data was only run for every other image), the **Sync**: pulldown may be used to synchronize the animation. The relevant sequences should be synchronized to the sequence with the *fewest* frames. When objects based

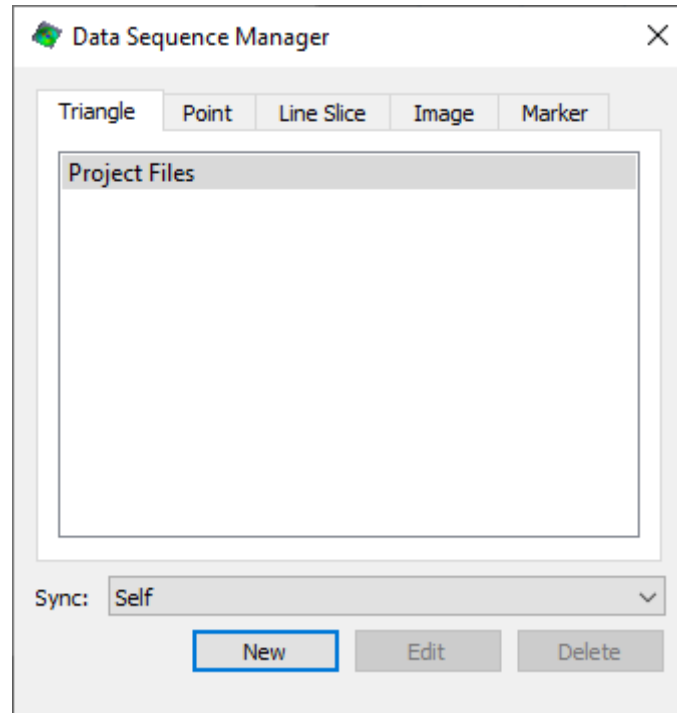

Figure 13.43: The sequence manager.

on the synchronized sequences are added to the workspace and given the same keyframes and easing, they will be synchronized to each other in time.

i Synchronization is accomplished by referencing associated camera 0 filenames. Because of this, the synchronization feature is mainly useful with data files (.OUT files) and corresponding images and extractions.

13.4.1 Mesh Data Sequences

iris supports import of several 3D mesh file formats, including VTP files (VTK polygon data) and Vic-3D OUT files. VTK is a very flexible package that allows import and conversion of STL, OUT, or FE mesh files.

Mesh files are added under iris tools dropdown box at the top toolbar, by using “Add File Sequence” shown in Fig. 13.44. Once selected, the user will be prompted to select a file and then name the sequence in the “Select Sequence Name” window shown in Fig. 13.45. This sequence name will be the data source recalled for the 3D plot.

Once the sequence name is given, the dialog window shown in Fig. 13.46 will appear. Prompting the user for additional information regarding the data source. If “Coordinates are deformed” is selected, then the displacement variable selection will be disabled.

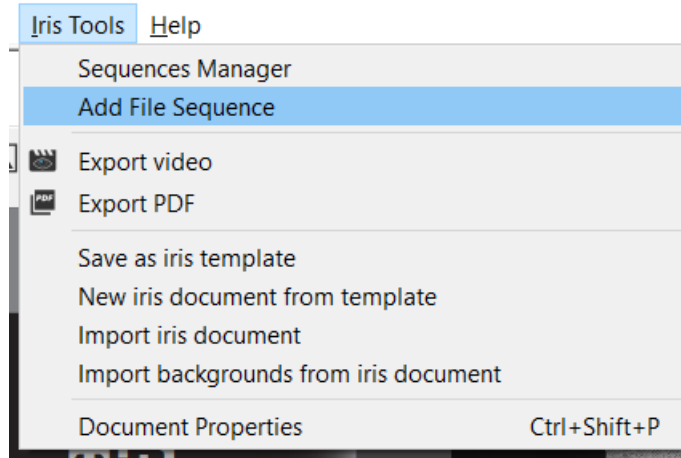

Figure 13.44: Add File Sequence menu.

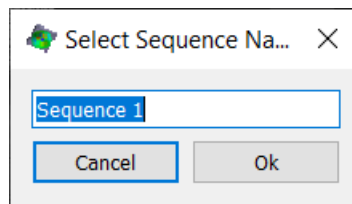

Figure 13.45: Selecting sequence name.

To insert a 3D VTK plot in *iris*, click the **3D** icon, and then click once in the document workspace to insert a 3D plot box. The 3D plot can be edited by clicking on the image once to move the position of the entire plot and double clicking to move the image in the 3D plot window.

i The data source of the 3D plot may be changed in the plot properties.

13.4.1.1 Plot Properties

The source, interpolation, time, and winding for the mesh data are set using the common [data tool](#).

13.4.1.2 View

The visual appearance of the 3D plot and axes are set using the shared [view tool](#).

13.4.1.3 Plot Positioning

The position, size, and rotation of the 3D plot are set using the shared [base tool](#).

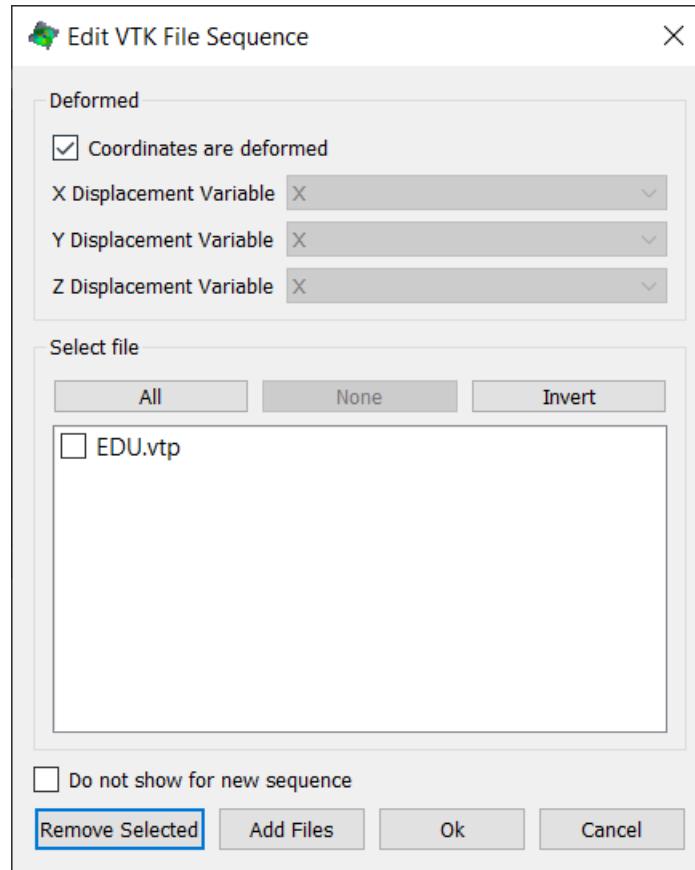



Figure 13.46: Edit VTK File Sequence dialog.

13.5 Working with Keyframes

A **keyframe** in *iris* is a position within the timeline where a user-defined value is specified. Examples of values that can be specified are:

- The position within the page of a text box
- The size of a graphic
- The ‘time’ parameter of a data plot

If a property value is specified at two or more keyframes, *iris* will smoothly interpolate the value between keyframes to create an animation of text moving, a graphic zooming in, a plot animating through time, etc. The Interpolation can be linear, or [easing options](#) can be selected for more natural appearing transitions.

Every value or attribute that can be animated using keyframes is indicated with an  icon next to the relevant control, and these attributes are referred to as *animatable* in this manual.

13.5.1 Adding Keyframes

Keyframes are added by clicking the  icon next to the desired value (Here in Fig. 13.47 the **Time** attribute for a 3D plot), and selecting *Add keyframe* from the dropdown.

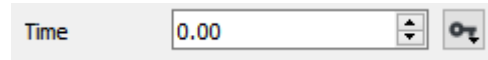

Figure 13.47: Time control showing keyframe icon.

A keyframe indicator will appear in the timeline at the bottom of the workspace, shown in Fig. 13.48.

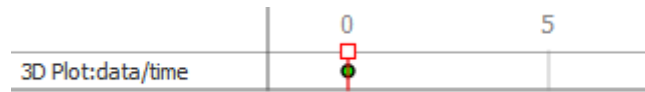

Figure 13.48: Timeline showing single keyframe.

The keyframe is indicated by time (here, 0 seconds) as well as the element and keyed property (3D plot, data/time). The entire timeline can be scrolled by clicking and dragging the times at the top. The current position *within* the timeline can be adjusted by dragging the small square, shown in Fig. 13.49:

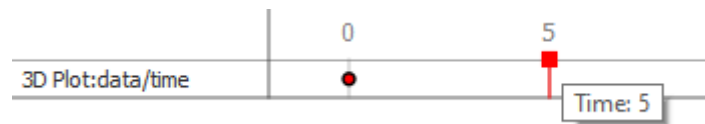

Figure 13.49: Timeline showing dragging.

On returning to the **Time** control, the key attribute has been disabled because the timeline is not currently at a keyframe, shown in Fig. 13.50:

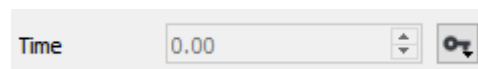

Figure 13.50: Timeline showing dragging.

To insert another keyframe at the new position in the timeline, the key icon can be clicked again and *Add keyframe* selected. The time attribute becomes editable; here, it has been set to 1.00, shown in Fig. 13.51:

The new keyframe also appears on the timeline, shown in Fig. 13.52.

The document now contains a single element: an animation of a 3D plot of the test data, from the first frame to the last, with a duration of 5 seconds.

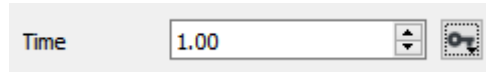

Figure 13.51: Timeline showing dragging.

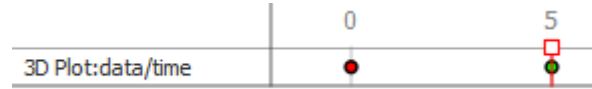

Figure 13.52: Timeline showing dragging.

i When exporting video, the animation will always begin at the first keyframe regardless of its position on the timeline. If the first keyframe is placed at 10 seconds, the video will start immediately there rather than being blank for 10 seconds. Blank video and transitions may be managed with the [Page Transition](#) settings.

i There is no limit on the number of keyframes; a third keyframe could be added to show the data returning to the start position, etc.

13.5.2 Adding more timelines

Multiple different attributes can be animated; each time a new attribute is keyed, a new timeline is added to the editor. In Fig. 13.53, an animated rotation has been added after the time animation.

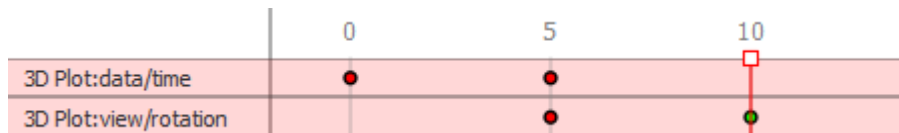

Figure 13.53: Timeline showing dragging.

13.5.3 Animating other items

Multiple items can be animated, and these too will be added to the timeline. If an object with keyframes is currently selected, the relevant row will be highlighted in red, shown in Fig. 13.54.

A document item may be selected by double-clicking it at the left of the timeline.

i Objects which are invisible or behind other items may be easily selected in this way.

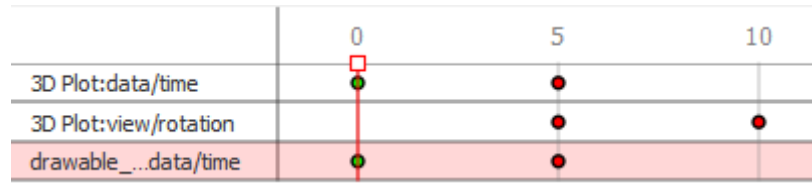



Figure 13.54: Timeline showing dragging.

13.5.4 Keyframe shortcuts

For common operations, adding keyframes can be simplified by selecting a shortcut from the  pull-down.

- For data plots, a simple forward, reverse, or forward-then-reverse animation of the data can be selected. For instance, “Forward 5s” repeats the operation described above to animate a 3D plot over 5 seconds, with a single click.
- For most position and miscellaneous attributes, a simple placement of keyframes at common time intervals can be selected. The values must be adjusted manually.
- For the opacity control, there are predefined fade-in and fade-out settings.

 The shortcuts will not overwrite or interfere with existing keyframes; if not enough blank space is available on the timeline, a warning will be displayed and the timeline will remain unchanged.

13.5.4.1 Easing Options

To control the interpolation and resulting visual effect for each animation, right-clicking on the keyframe at the *end* of the specified animation will allow selecting an easing option.

In animation, *easing* is used to make motion look more natural. A linear motion with an instantaneous start and stop will appear artificial; adding smooth start and stop, acceleration, or “bounce” effects can remedy this.

Easing options may be selected by right-clicking the keyframe indicator at the end of the relevant animation and choosing from the **Easing** submenu. Six main categories of predefined easing options are available:

Linear - motion uses linear interpolation only (no easing).

Quad - quadratic curves for motion.

Cubic - cubic curves for motion.

Elastic - ‘spring’ effects.

Bounce - ‘bounce’ effects with rebound.

Back - adds an overshoot.

Each easing option can affect the beginning motion (**In**), the end motion (**Out**), both (**InOut**), or work from the center out (**OutIn**).

Selecting **Customize** allows further customization of the exact parameters of the easing curve, as well as being a convenient way to preview the nature of each easing curve.

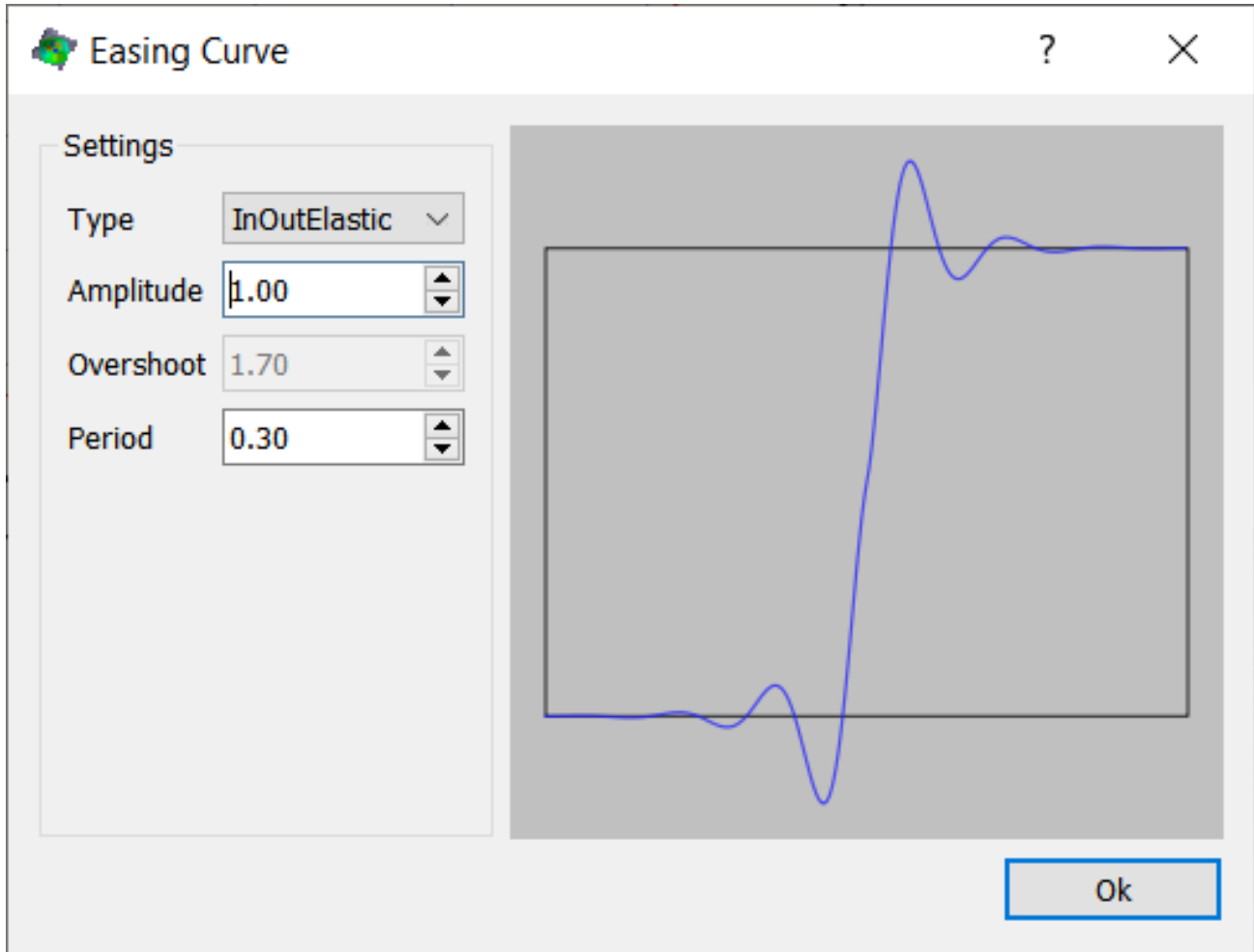

Figure 13.55: Customize Easing Options.

13.6 Document Properties

Each *iris* document has a set of global properties that control page size, transitions, grid settings, document defaults, and graph styles. These document properties may be edited by clicking **Document Properties** in the **Iris Tools** menu, or by pressing Ctrl+Shift+P.

13.6.1 Page size

A list of standard page sizes can be selected as shown in Fig. 13.56, or a **Width** and **Height** can be entered in the desired units (selected using the pulldown).

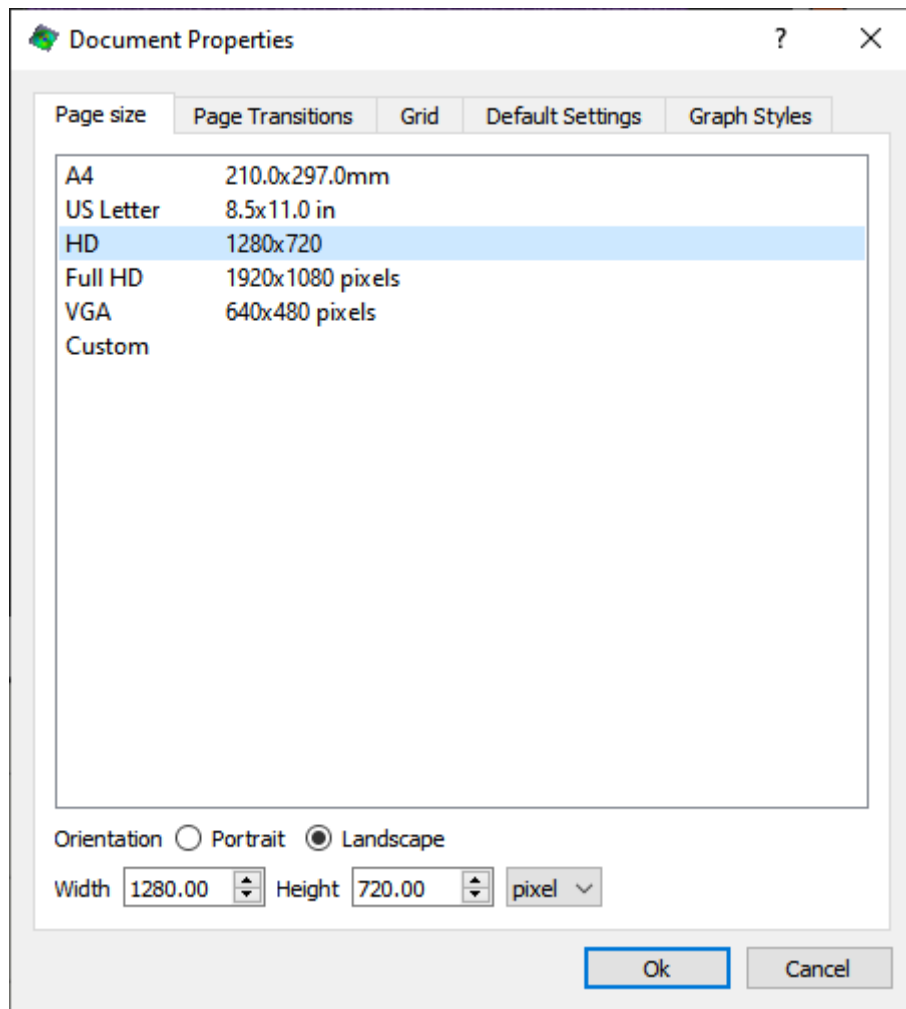

Figure 13.56: Page size tab.

13.6.2 Page transitions

The duration of each blank page is controlled with the **Empty page duration** value. For each transition, a start and end fade style can be chosen, along with a fade duration. These selections are shown in Fig. 13.57.

13.6.3 Grid

A grid can be overlaid on the main workspace by checking **Show grid**, or pressing the “#” key on the keyboard. Grid spacing and appearance is set by using the controls shown in Fig. 13.58.

13.6.4 Default Settings

Default settings for each *iris* element may be modified by selecting the desired element from the **Category** pulldown. These options are shown in Fig. 13.59.

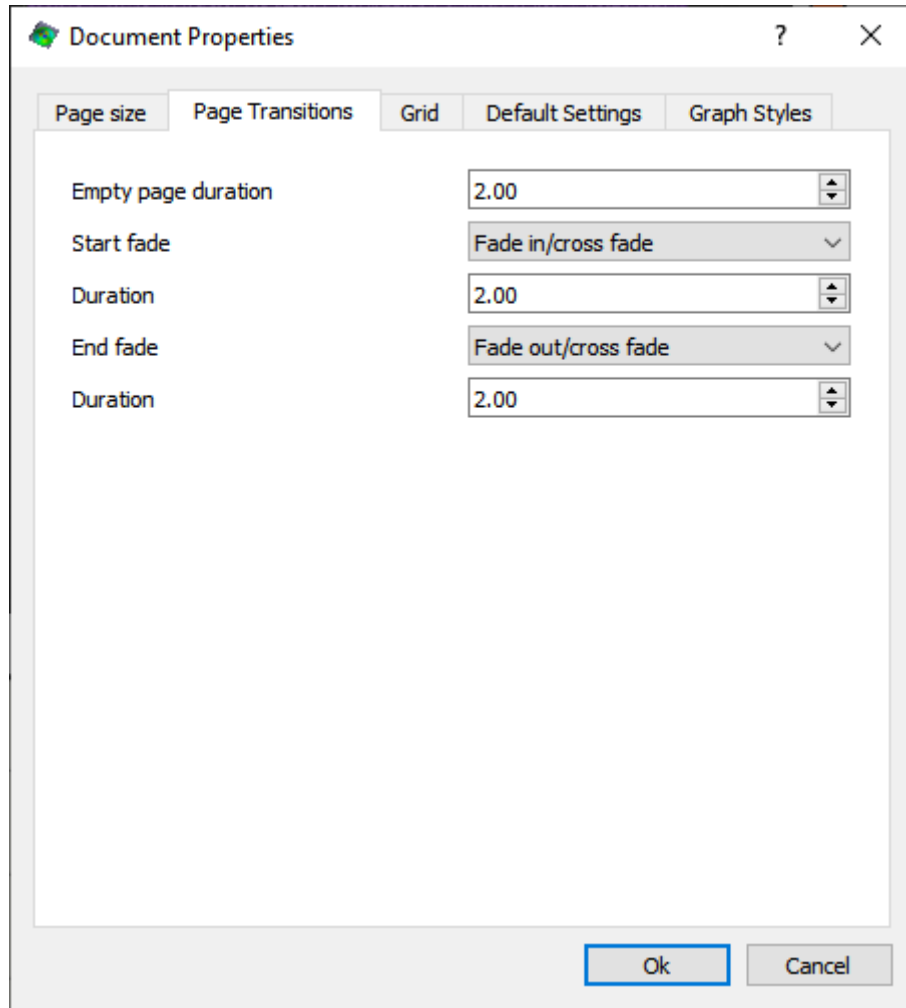

Figure 13.57: Page transitions tab.

If the checkbox to the left of a property is clear, a global default will be used. If it is checked, the value entered will be used for the property for new objects.

13.6.5 Graph Styles

Default settings for each graphing style may be modified within the graph styles tab. Select *Ok* to save the changes. These options are shown in Fig. 13.60.

i Graph style 12 is reserved for background traces.

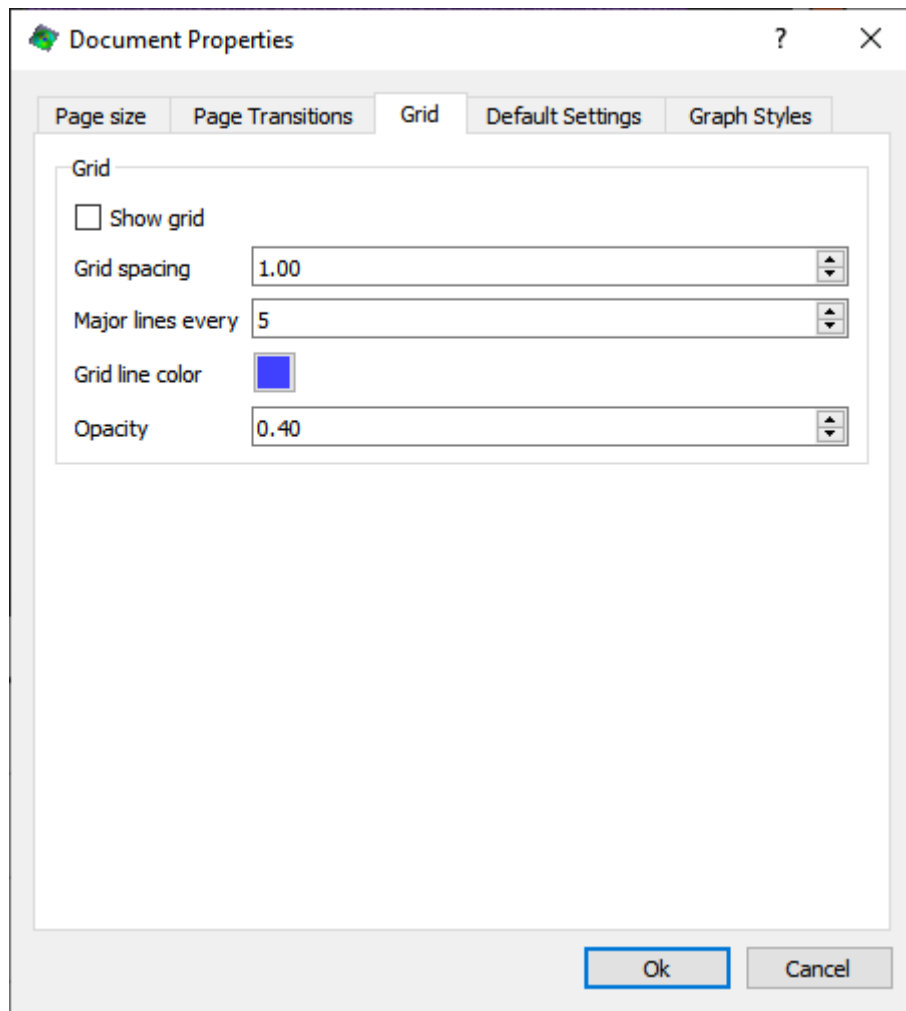



Figure 13.58: Grid tab.

13.7 Exporting *iris* Content

iris documents may be exported to video by selecting *Export video* from the *iris tools* menu, by clicking the  icon in the main *iris* toolbar, or by pressing the “V” key on the keyboard. The export content dialog box can be seen in Fig. 13.61.

13.7.1 Output

A filename and folder may be chosen by clicking the folder icon.

Choose a video resolution by selecting from the **Video format** pulldown; **Frame rate** allows selecting from standard frame rates for video, and **Quality** controls the compression factor and resulting video quality.

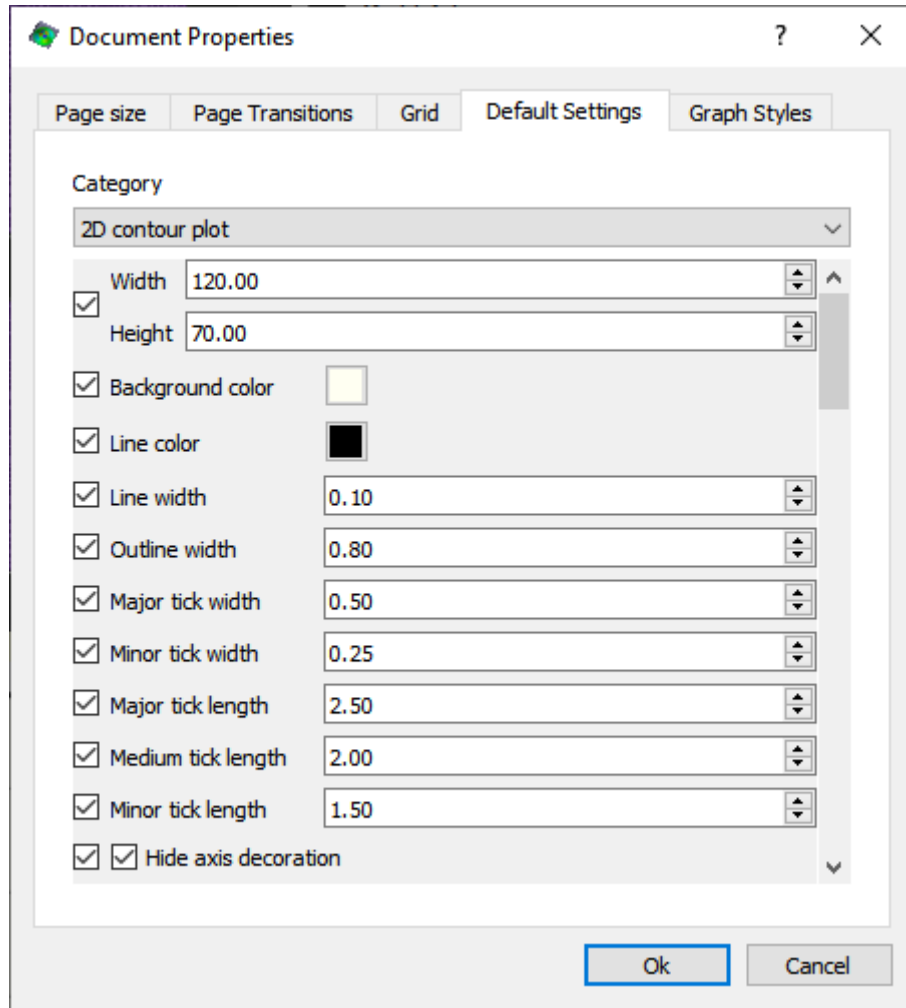

Figure 13.59: Default settings tab.

i Higher resolutions and frame rates will take longer to render and result in larger file sizes.

The **Adaptive motion blur** checkbox enables a motion blur for realistic appearing motion. This is calculated by interpolating a number (**Max. blur samples**) of frames between each existing frame. The blurring will be applied when motions greater than the **Min. blur length** are present anywhere in the frame.

13.7.2 Global transition Settings

These settings control the display length of an empty page, and the duration and style of the start and end fades. Clicking the **Fade background** checkbox will cause the selected **background** to be faded in and out as well, rather than static.

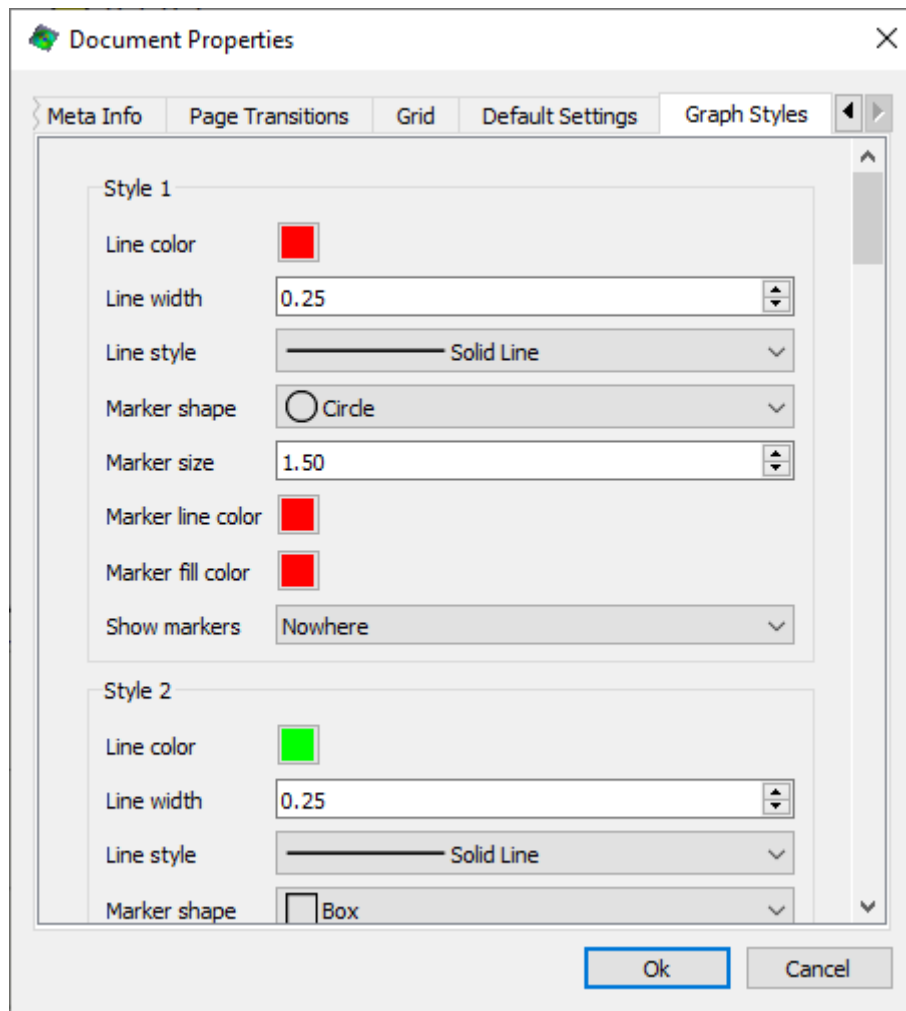

Figure 13.60: Graph styles tab.

13.7.3 Exporting *iris* Content as a PDF

A PDF of the content created with *iris* can be exported by selecting *Export PDF* from the *iris tools* menu, by clicking the PDF icon in the main *iris* toolbar, or by pressing the “E” key on the keyboard. The export dialog is shown in Fig. 13.62.

13.7.3.1 Output File

The filename for the exported PDF can be entered in the **File** input box. Clicking the folder icon allows selection of the output folder.

13.7.3.2 Settings

The **Settings** box in the export window allows export of **All pages**, the **Current page**, or the current **Selection**. The resolution for export (in dots per inch) can also be found here.

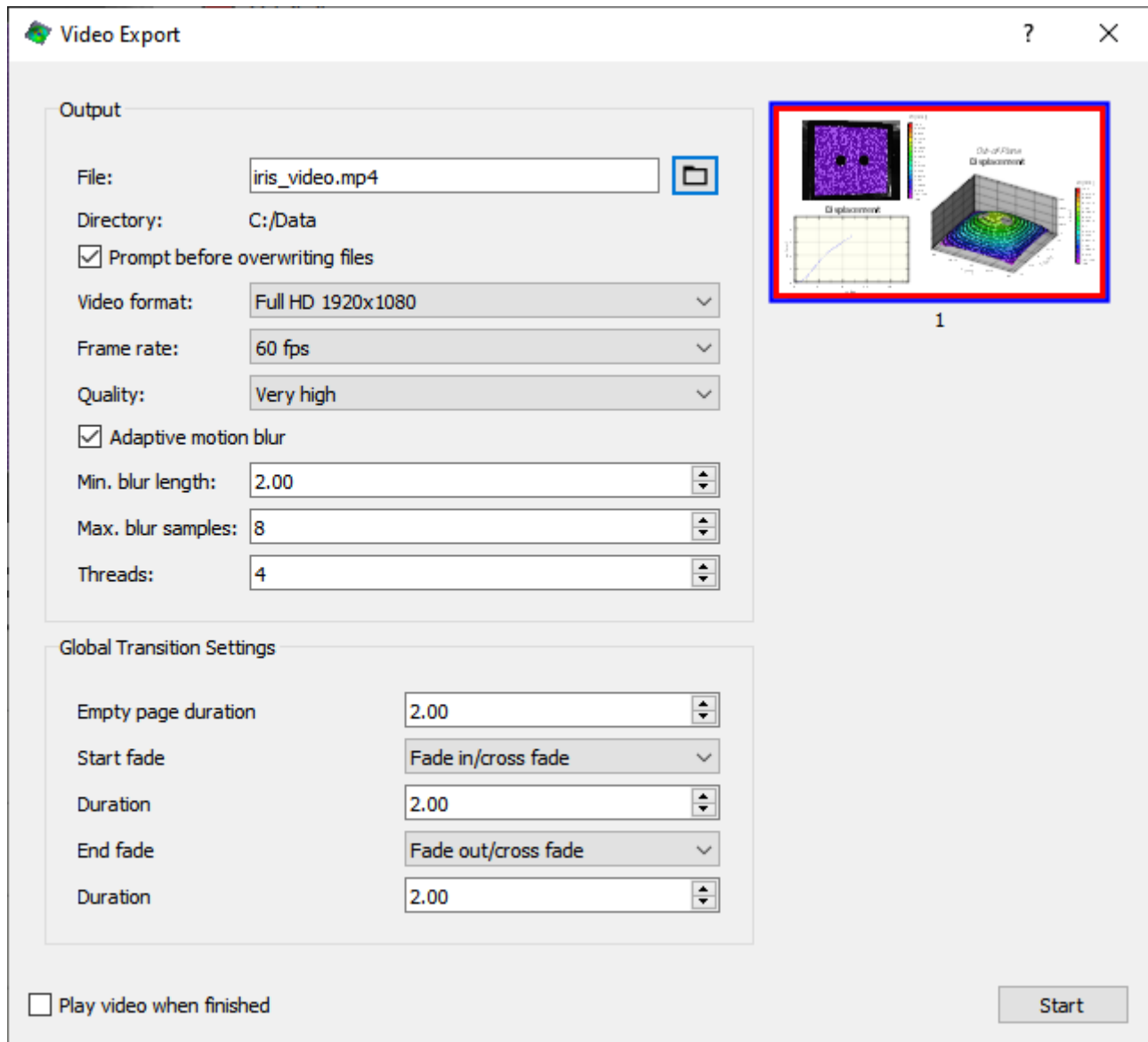
Figure 13.61: *iris* Export dialog.

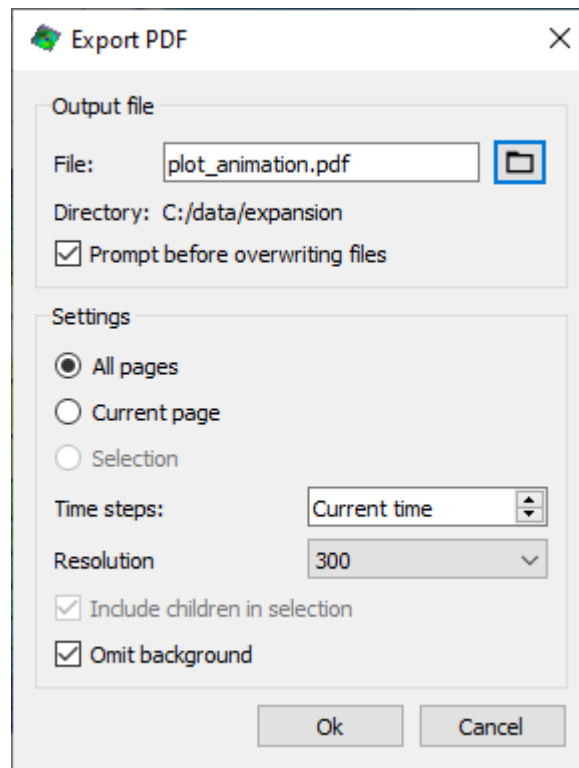

Figure 13.62: *iris* PDF Export dialog.

By default, the output will be generated for the current time set for each page. It is also possible to automatically sweep the timeline on each page and generate one page for each time step. The number of time steps can be controlled via the spin box labeled **Time steps**.

i The maximum selectable resolution depends on the rendering capability of the PC and the size of the document.

When **Selection** is chosen, a scalable SVG file may be created by checking **Generate svg file**.

i SVG files are scalable and are the best choice for inclusion in Word® documents, etc.

To omit any background present in the page, check **Omit background**. For SVG export and when **Selection** is chosen, the background is always omitted.

If **Include children in selection** is checked any child objects of the selected object will also be exported (e.g., contour legends for a data plot.)



To enable SVG export, *Inkscape* must be installed. Information about Inkscape as well as the latest installer may be found at inkscape.org.

Chapter 14

Report Generation

Vic-3D can generate reports from template documents. Special tags are used in the documents as placeholders for project-specific data such as calibration values, analysis settings, images or plots. During report generation, Vic-3D fills in the template with the data from the current project and writes a new document to the hard drive.

14.1 Report Generator Dialog

To create a report after running an analysis, click *File... Report* from the main menu.

You can choose from installed Text documents or Presentations by selecting the tab at the top. The preset location for these templates is under your Documents folder in the VicReportTemplates subfolder. Supported filetypes are:

- **.odt**: OpenDocument document.
- **.docx**: Microsoft XML document (Word).
- **.odp**: Open Document presentation.
- **.pptx**: Microsoft XML presentation (PowerPoint).

You can add to the template library by placing new templates in this folder. Click on a template to continue, or click **Other** to select any other file.

Important note: if a tag is broken up by formatting, revision tracking, or spell checking, it will not be processed. It is usually best to turn off all change tracking and spelling/grammar checking in your word processor.

14.2 Report Options

Image resolution:

- Screen: for plots/images, uses the same resolution as the display, for viewing on screen.
- Print: upscales images for a better printed image.

Scaling:

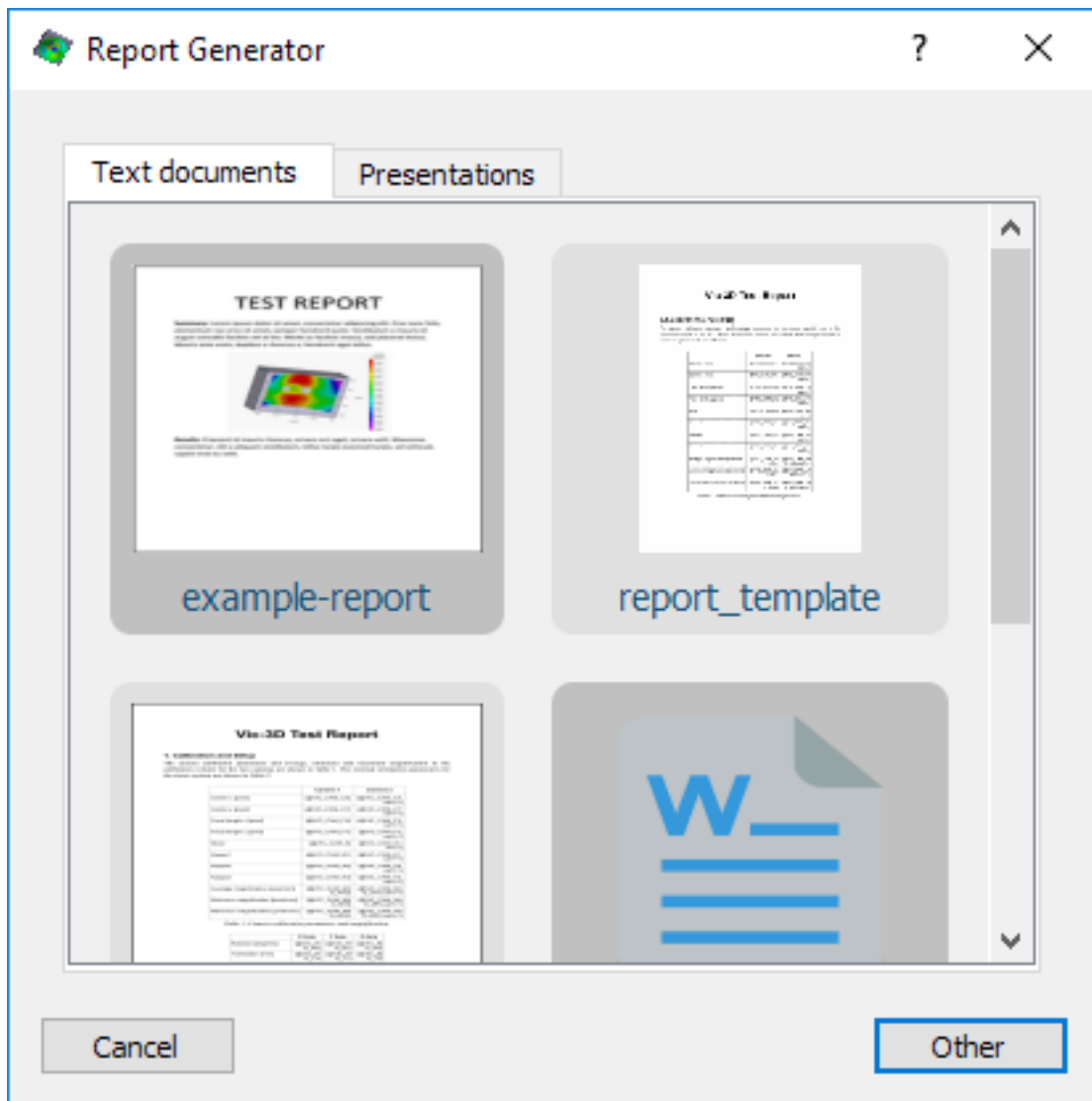

Figure 14.1: Report dialog

- In Print image resolution, choose nearest neighbor (faster) or smooth (better quality).

Video settings:

- Encoder: choose encoding method (built in AVI or external convertor).
- Format: choose a preset format (faster, higher quality, etc).
- Frame rate: select a frame rate for video display.

To open the report after completion, leave the checkbox selected. Click Ok to begin; the document will be filled out, replacing tags with quantities, images, tables, and videos. For more detail on available tags, consult the [Report Template Tags](#) reference.

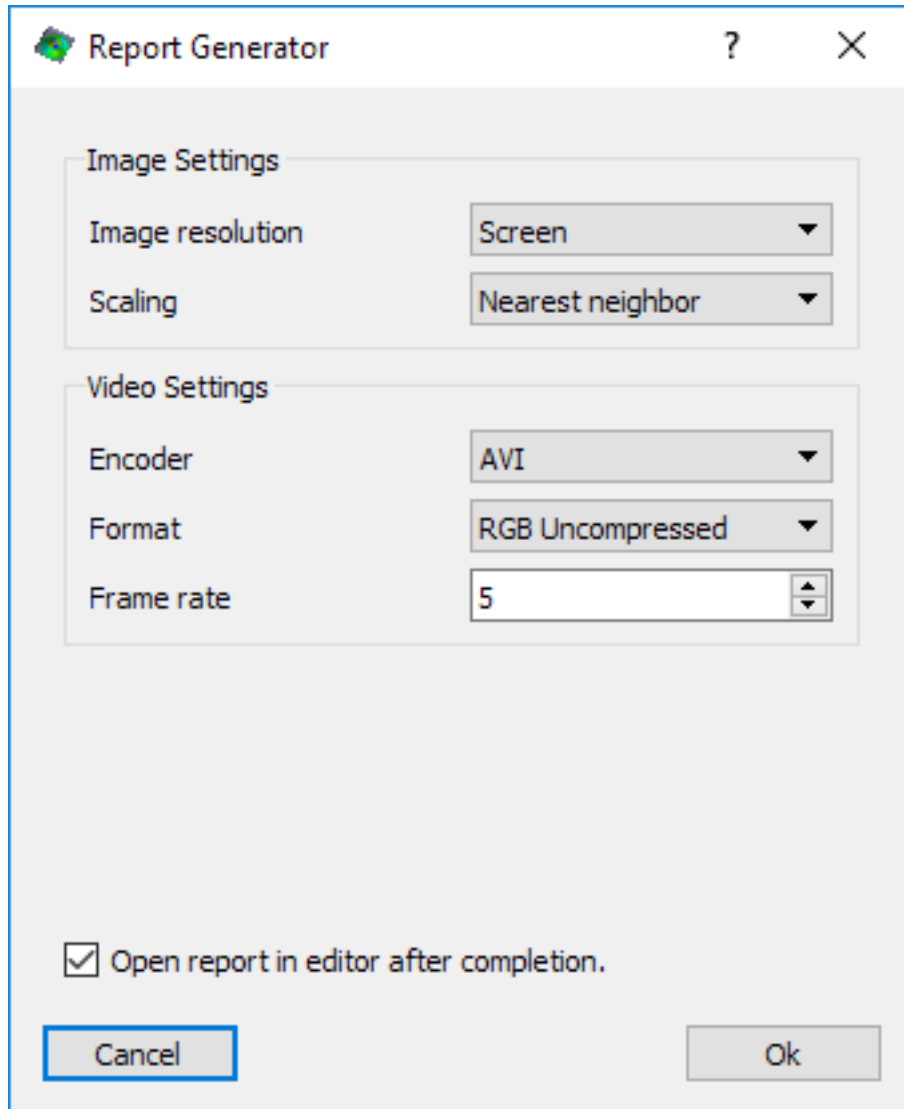

Figure 14.2: Report options page

14.3 Template Tag Reference

14.3.1 Basics

To insert a text tag, place the tag and any parameters, separated by commas, inside braces. The tag will be replaced by the appropriate value without changing the font, position, etc. For example, `{@VIC_RIG_TX}`.

To insert a graphic tag, create a blank or placeholder image and then add the tag and any parameters as the **alternative text**. The image will be replaced by the requested plot. For example, `{@VIC_PLOT_3D,var=e1,idx=-1}`.

Important note: if a tag is broken up by formatting, revision tracking, or spell checking, it will not be processed. It is usually best to turn off all change tracking and spelling/grammar checking in your word processor.

14.3.1.1 Format specifiers

Many tags have format specifier flags.

- `fmt`: floating point format
 - ‘f’: display as 7.7
 - ‘g’: uses either regular format, or scientific notation (e.g., 1e+3) if more concise
- `prec`: precision specifier (number of digits after decimal for ‘f’ or total number of floating point digits for ‘g’)

Spreadsheet column specifiers have the format `COL_ID:FMT:PREC`, where

- `COL_ID`: spreadsheet column (A, B, C, . . . , AA, AB etc.)
- `FMT`: number format ‘f’, ‘g’ (optional)
- `PREC`: number of digits (optional)

List indices:

Any time a list index *idx* is present, you may specify integer values starting from 0, or negative values to count down from the end; e.g., -1 refers to the last element. Alternatively, indices can be specified as a percentage, e.g., 33.33%. If indices are specified as percentages, the closest integer value is used.

14.3.2 Analog or Spreadsheet Data Tags

`VIC_ADATA`

Used to insert data from the project’s analog data file (CSV) for time, load, etc.

- `idx`: Index value
- `col`: column (A, B, C, . . . , AA, AB)
- `fmt`: floating point format (‘g’, ‘f’)
- `prec`: precision specifier (number of digits)

Example: `{@VIC_ADATA, idx=100%, col=B, fmt='f', prec=1}` shows the second column (normally `Time_0`) from the analog data file for the last image in the test, floating point, 1 digit of precision.

Example: `{@VIC_ADATA, idx=10, col=H}` shows the 8th column (i.e., Load, in a given setup) from the 10th image in the test.

`VIC_CSV_DATA`

Used to insert data from external csv files. Can be used either to look up spreadsheet cell entries (e.g., `cell=B3`) or for key-value pair lookups. In the latter usage, one column in the csv file is used as the key column and should hold unique descriptors of the values in the value column. For instance, the key column could have entries ‘modulus’, ‘poisson’, ‘sample_id’ and the value column would contain the numerical values for the elastic modulus, the poisson ration and the sample’s identification number.

- file: path to csv file on disk
- cell: spreadsheet cell (e.g., A1, C32)
- key_col: column that holds keys for key-value pair lookups
- val_col: column that holds values for key-value pair lookups
- key: string in key column
- fmt: floating point format ('g', 'f')
- prec: precision specifier (number of digits)

Example: `{@VIC_CSV_DATA, file=testinfo.csv, cell=B3}` - shows the value from cell B3 of the specified spreadsheet.

Example: `{@VIC_CSV_DATA, file=testinfo.csv, key_col=D, val_col=E, key=modulus}` - scans row D for the keyword “modulus” and pulls the matching value from row E.

14.3.3 Calibration values

The following calibration values all support the basic options:

- cam: camera id (default: 0)
- fmt: floating point format ('g', 'f')
- prec: precision specifier (number of digits)

VIC_CAM_CX, VIC_CAM_CY

x/y center coordinates (pixels)

VIC_CAM_FX, VIC_CAM_FY

x/y focal length (pixels)

VIC_CAM_S

skew factor

VIC_CAM_K1, VIC_CAM_K2, VIC_CAM_K3

distortion coefficients

VIC_CAM_MAG_AVG, VIC_CAM_MAG_MIN, VIC_CAM_MAG_MAX

average, minimum and maximum magnification (pixels/mm)

VIC_CAM_ERROR

residual error for calibration (pixels); use **cam=-1** for the rig error.

Example: `{@VIC_CAM_CX, cam=1, 'f', 2}` shows the center (x) for camera, floating point, 2 digits of precision.

Example: `{@VIC_CAM_ERROR}` - shows the error score for camera 0 with no formatting.

Example: `{@VIC_CAM_ERROR, cam=-1}` - shows the overall error score for the rig.

The external camera calibration values support the following options:

- fmt: floating point format ('g', 'f')
- prec: precision specifier (number of digits)

VIC_RIG_RX, VIC_RIG_RY, VIC_RIG_RZ

rotation angles (degrees)

VIC_RIG_TX, VIC_RIG_TY, VIC_RIG_TZ

translation vector (mm)

Example: `{@VIC_RIG_RY}` – shows the RY (stereo angle) for the rig.

14.3.4 Analysis Settings**VIC_STRAIN_FILTER_SIZE**

size of strain filter used (pixels)

VIC_STRAIN_TENSOR

type of tensor

VIC_SUBSET_SIZE

subset size (pixels)

VIC_STEP_SIZE

step size (pixels)

Example: `{@VIC_SUBSET_SIZE}` – show the subset size for the analysis.

14.3.5 Tables (VIC_TABLE_CSV)

The template generator supports generation of tables from comma-separated variable files using the tag `VIC_TABLE_CSV`. This tag has to be added to the name field (ODT) of an existing table. The last row of the table in the template must contain spreadsheet column specifiers. The following options are supported:

- `file`: path to csv file on disk
- `start`: integer value for start row
- `end`: integer value for end row, or -1 to use entire table

14.3.6 Plots**@VIC_PLOT_2D**

Inserts a 2D plot. 2D plots support the following options:

- `idx`: the image index (default 0)
- `cam`: the camera to view (default 0)
- `var`: the name of the variable to plot (default “W”)
- `c_range`: the contour range, separated by a colon

@VIC_PLOT_3D

Inserts a 3D plot. 3D plots support the following options:

- `idx`: the image index (default 0)
- `cam`: the camera to view (default 0)
- `var`: the name of the variable to plot (default “W”)
- `c_range`: the contour range, separated by a colon

- `view_angles`: the 3 viewing angles, separated by colons (default 60:0:30)

@VIC_IMG_EXTERNAL

Inserts an arbitrary image. External images support the following option:

- `file`: the file name

@VIC_IMG_REFERENCE

Inserts the reference speckle image. The reference image tag supports the following options:

- `cam`: the camera to view (default 0)

@VIC_IMG_SPECKLE

Inserts a speckle image. The speckle image tag supports the following options:

- `idx`: the actual image number (not a percentage or negative number)
- `cam`: the camera to view (default 0)

@VIC_IMG_AOI

Inserts the reference image with the AOI overlaid. The AOI image tag supports the following options:

- `subset`: set “subset=true” to show the subset grid overlaid on the AOI.
- `startpoints`: set “startpoints=true” to show start points overlaid on the AOI.

Chapter 15

Marker Tracking

To enter the marker tracking mode in Vic-3D, click the  button in the main toolbar, or select *Project... Marker editor* from the main menu. The marker tracking toolbox will appear at the top right:

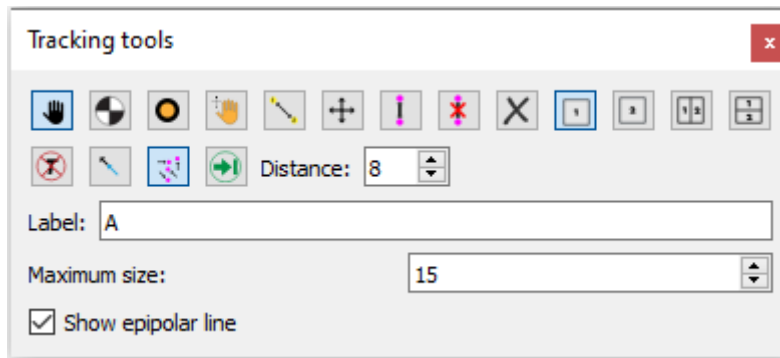









Figure 15.1: Marker tracking tool box.

To switch between different image views, you can click the     buttons to view the camera 1 image, camera 2 image, or both at once in a horizontal or vertical tile. Markers may initially only be placed on the camera 1 image.

15.1 Placing Markers



To place markers on the image, click either  or  to place an elliptical or quadrant style marker. (You can also place a marker on any visible feature using the  tool, but it will not be automatically tracked and must be manually placed for every image.) Then, click in the image (“Marker Editor 1”) to place the marker as illustrated in Fig. 15.2.

If a marker is found, the position of the placed marker will snap to the marker center. For best marker fitting and tracking, you can use the **Maximum size** control to select the approximate size (in pixels) of your markers; this will prevent false matches on marker edges or object corners.

After the marker is placed in the camera 1 image, it must be matched in the camera 2 view for stereo tracking. Start by making sure the relevant marker is selected (markers can be selected



Figure 15.2: Marker placed in image.

using the  tool). Click the  (associate marker) tool, and click the matching marker in the camera 2 view. If the **Show epipolar line** box is checked, a green constraining line will be displayed in the matching image to help identify your choice. The marker should snap to the detected image marker, as illustrated in Fig. 15.3.

To place more markers, continue to add markers in the “1” image and associate them in the “2” image. If desired, a marker can be labeled with alternate text by selecting the marker, and then entering the label in the **Label** field in the marker tool box. The labels will be shown in the images, as shown in Fig. 15.4.

15.2 Tracking

To begin tracking markers, select  (Track all) to track all placed markers. Then, use the Animation tools to either step through images one at a time, or play through all images. Vic-3D will attempt to find the new marker positions in each image.

In some cases of large motion or closely placed markers, Vic-3D will be unable to track the marker and you must provide an initial position. When this happens, the marker will be flagged with a “?”:

To correct the position, use the  tool to drag the marker close to the center. Vic-3D will lock on to the new position and you can continue tracking through images.

If Vic-3D cannot find the marker automatically, it may be necessary to force a position. To

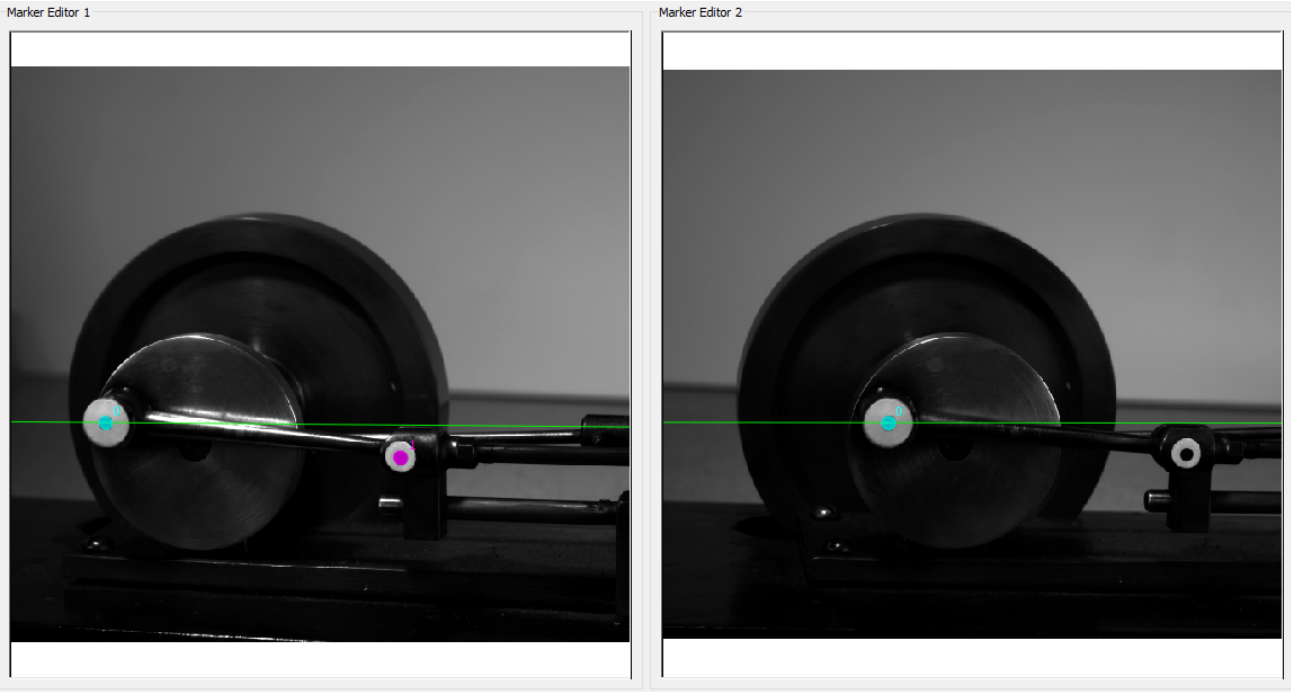

Figure 15.3: Marker snapped to correct location.

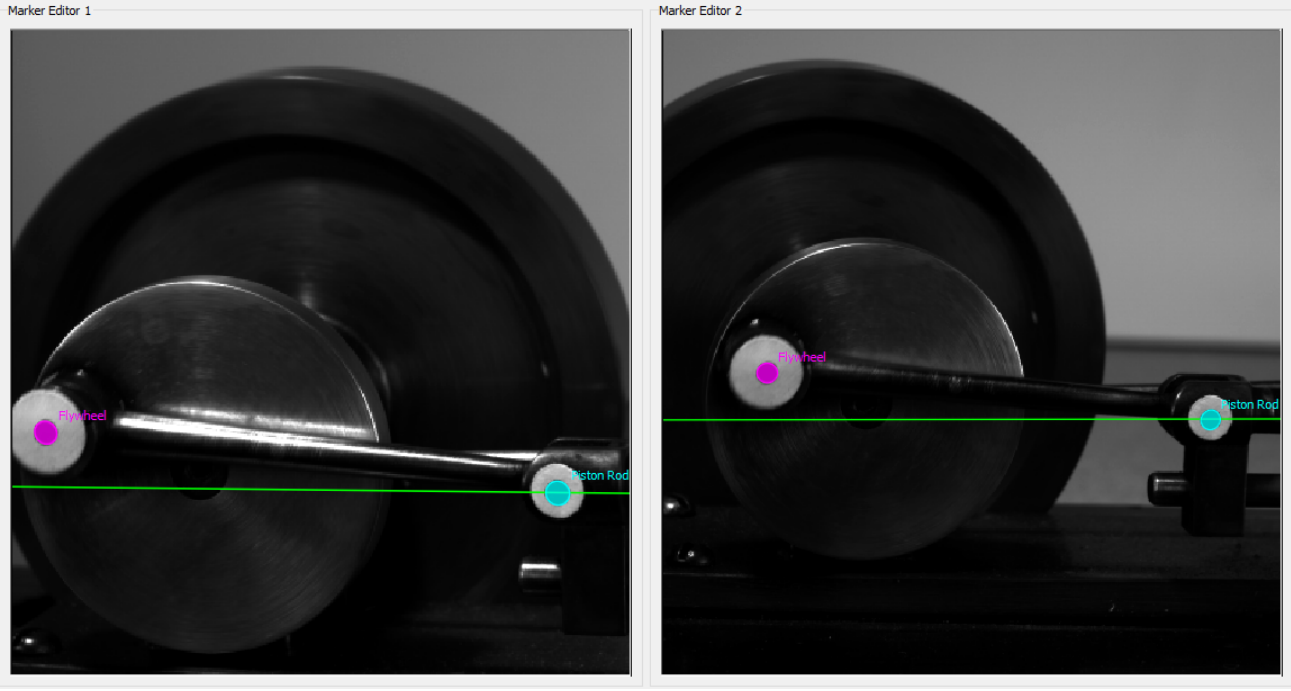

Figure 15.4: Custom marker labels.

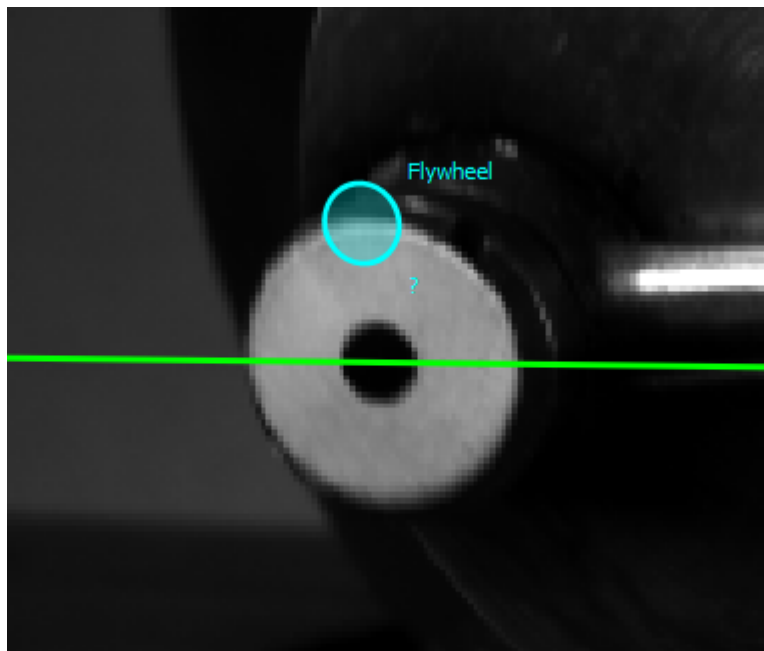

Figure 15.5: Tracking error.

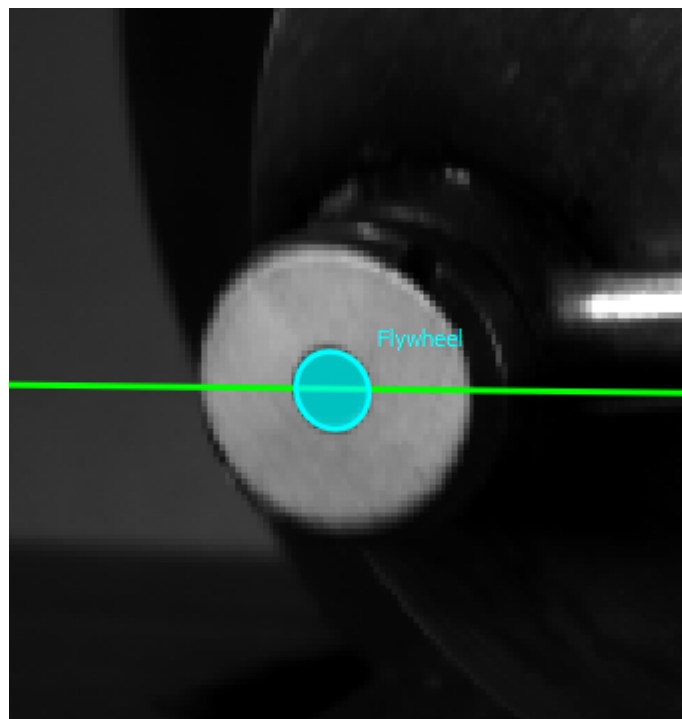



Figure 15.6: Tracking error corrected.

do this, use the \oplus (place manually) tool. This will give less accuracy than the subpixel marker matching algorithm within Vic-3D so it should be used only when the marker cannot be found automatically.

When many manual positions are required, it may be more convenient to turn tracking off for some or all points. To select a different tracking mode, click \otimes to track no markers, or \oplus to track only the selected marker.

Once all marker positions have been tracked, you can [export](#) the marker data.

15.3 Marker Triangulation

Once all markers have been placed and tracked, select the  icon to open the triangulation settings dialog shown in Fig. 15.7.

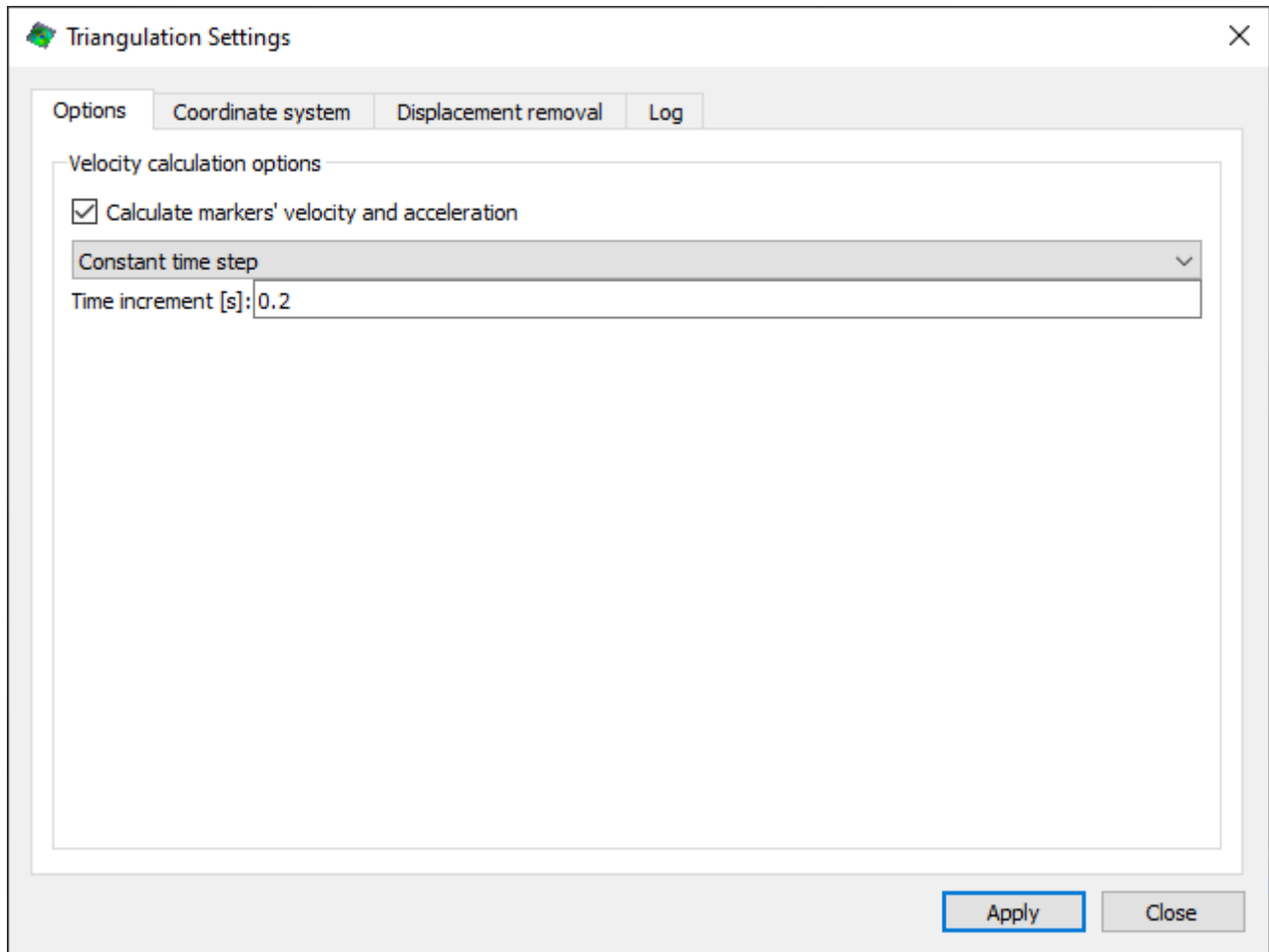



Figure 15.7: Marker Variables Dialog .

Selecting options you can calculate velocity and acceleration from inputting a constant time step, frame rate, or time from file. Selecting Coordinate system you can change the coordinate

system or apply a plane fit using the markers that have been placed and tracked, at the bottom of this dialog window you can provide a reference frame for the transform. Selecting displacement removal you can set a marker as fixed and remove the rigid motion of this marker.

15.4 Marker Visualization in *iris*

Once all markers have been placed, tracked, and triangulated connections can be visualized in *iris*, to do this use the  on camera 1 image. To delete linkages use the  and select the linkage.

Marker data visualization in *iris* is discussed under the relevant 2D or 3D plot selections [here](#).

15.5 Exporting Marker Data

To export tracked marker data, click on *Data... Markers... Export marker data* in the main menu bar. You will be prompted for a save file name, and then the Export markers dialog will appear, as illustrated in Fig. 15.8.

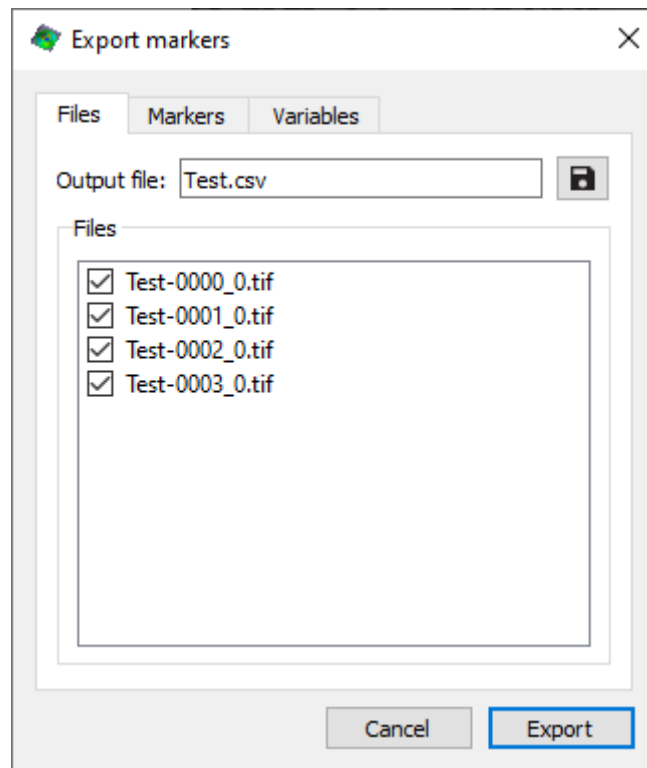

Figure 15.8: Marker export dialog.

15.6 The Files Tab

To select a new output file, click the icon next to the **Output file** label.

The **Files** list allows selection of files to process for export. By default, locations are exported for each file, but you may select any number of files. Right-click in the list to modify your selection or select preset intervals.

15.7 The Markers Tab

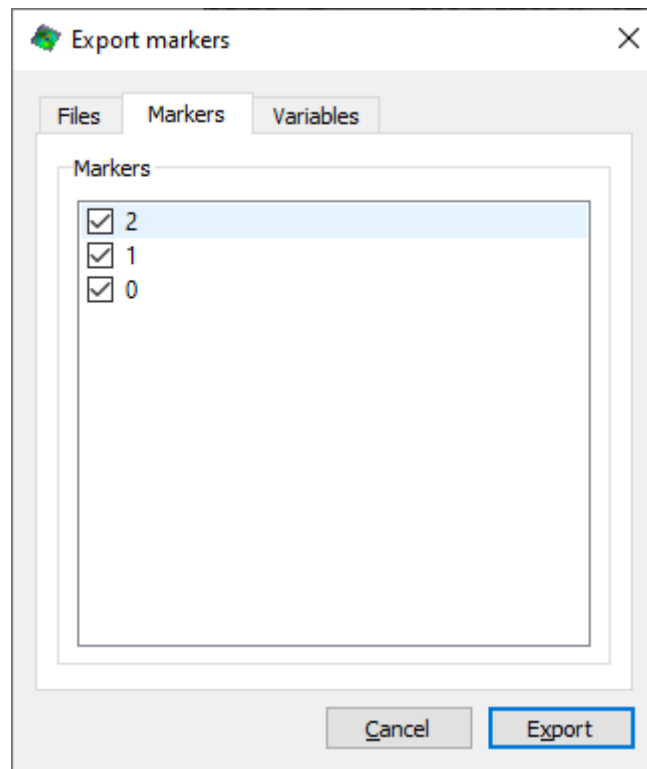

Figure 15.9: Markers tab in marker export dialog.

This tab lists the markers and allows you to select which ones to export data for. Select one or more, or right-click to select a range or interval.

15.8 The Variables Tab

Use this tab to select output variables. The available output variables are:

- X, Y, Z: spatial location of each point
- U, V, W: displacement of each point, relative to the chosen reference frame
- Projection error: error in match location between left and right camera
- x0, y0: pixel location of the marker in the camera 1 image

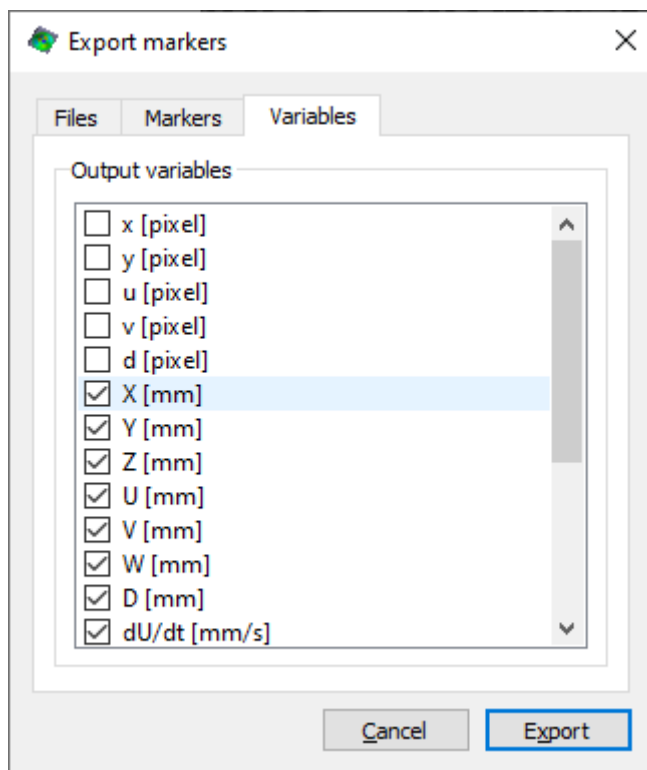

Figure 15.10: Variables tab in marker export dialog.

- x_1, y_1 : pixel location of the marker in the camera 2 image

Chapter 16

FFT Analysis

Vic-3D incorporates a mode for transforming time-domain displacement and strain into the frequency domain. The FFT workspace is accessed by clicking the FFT icon (\mathcal{F}) in the toolbar. If FFT data is not already present in the project, the following prompt will appear:

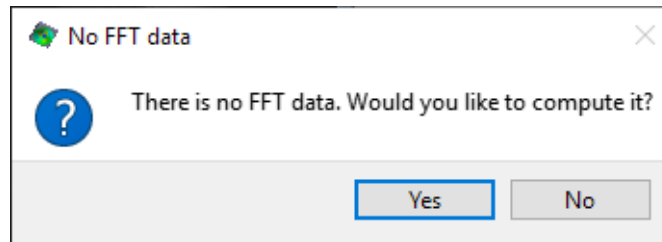

Figure 16.1: FFT computation prompt.

Clicking **Yes** opens the Frequency Analysis dialog.

16.1 The Frequency Analysis Dialog

Click *Data... Postprocessing tools... Frequency analysis* will open them Frequency Analysis dialog.

The available data set is displayed on the right. The default FFT analysis window is displayed as a box; the area may be redefined by clicking and dragging within the data plot. The mouse wheel is used to zoom; holding the Shift key will toggle pan mode.

16.1.1 The Settings Panel

- Overlaid on the data is a grid of analysis points. Each of the green points will be analyzed and converted to the frequency domain for later plotting; red points indicate areas where no data is present. The sample step may be adjusted with the **Sampling step** spin box; smaller sample steps will require more memory and slightly more analysis time.
- For the frequency to be calculated correctly, the correct image time step must be entered in the **Time step** spin box; this can be specified in terms of frequency by pulling down to **Frequency [Hz]**.

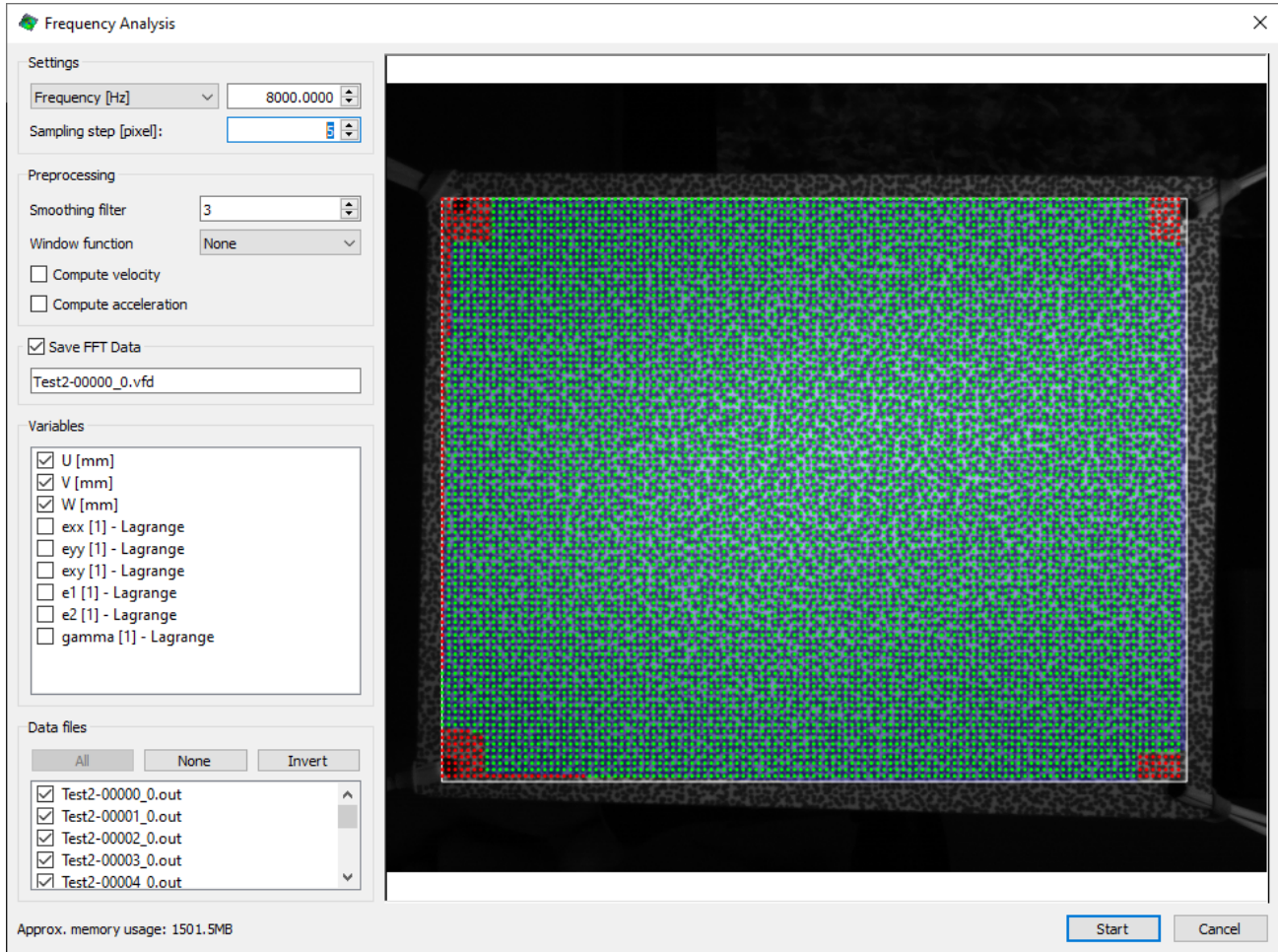

Figure 16.2: Frequency analysis dialog.

- Data to be used for frequency analysis often involves very small displacements which may be difficult to resolve; because of this, a smoothing filter can be applied during the FFT analysis. The radius for the filter is set using the **Smoothing filter** spin box; a value of 1 applies no smoothing.

16.1.2 The Preprocessing Panel

- Optionally, a **window function** can be applied to the data. Currently, the Hann and Hamming window functions are supported.
- Velocities can be computed by checking the **compute velocity** check box. The velocities will be computed for the selected displacement variables.
- Similarly, checking **compute acceleration** will compute the accelerations for the selected displacement variables.

When the **Save FFT Data** box is checked (default), the FFT data will be saved to disk. A filename may also be specified. If this box is cleared, the analysis will need to be re-run to

recreate the data again.

Additional or fewer variables may be selected for extraction in the **Variables** list. Selecting more variables will use more memory.

The data files to be included are listed in the **Data files** group box and certain data files may be removed if desired.

When the settings are correct, clicking the **Start** button will start the analysis (this can be time consuming for large data sets). After the data has been processed, the frequency workspace will be displayed.

16.2 Frequency Workspace

Once the analysis is complete, the Frequency workspace will be displayed.

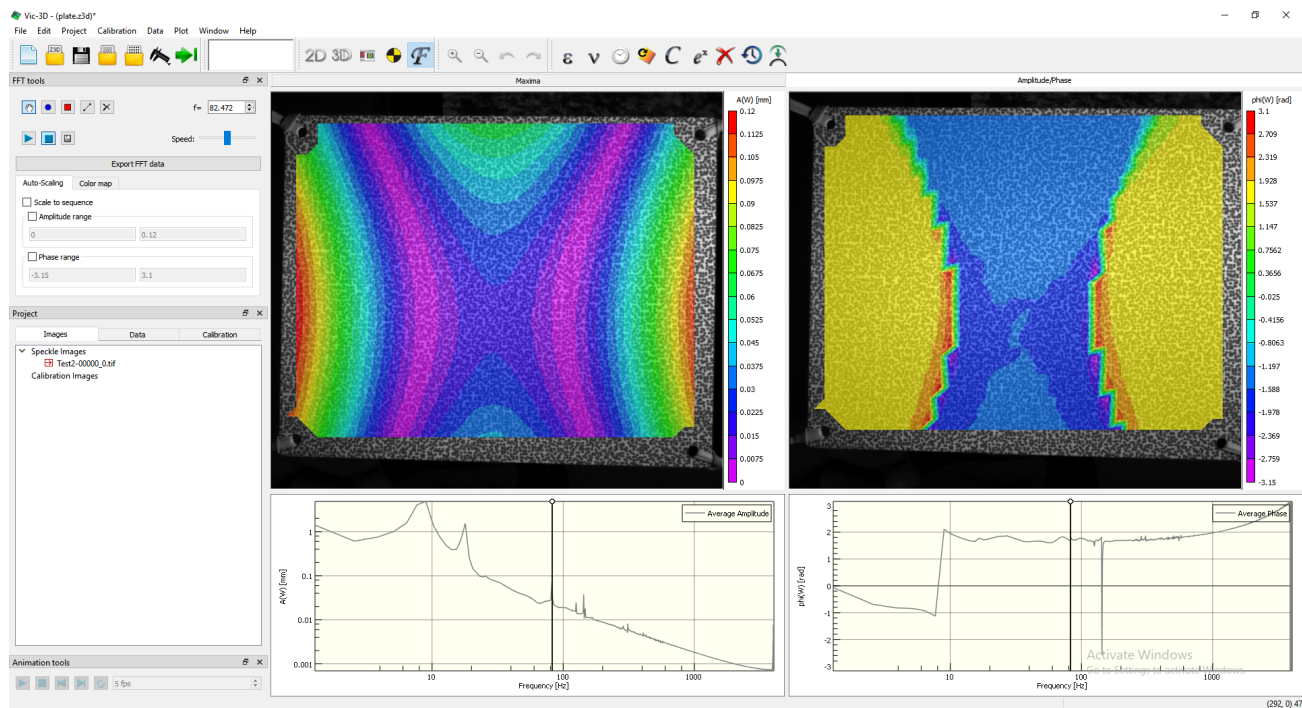

Figure 16.3: Frequency workspace.

16.2.1 Maxima Plots

The top left plot shows the maximum *amplitude* for the selected variable, and the top right plot shows, for each point, the *frequency* corresponding with this maximum amplitude. Right-click in either plot and selecting **Variable** will allow the choice of display variables. The mouse wheel may be used to zoom, and clicking and dragging will pan the plot.

These plots may also be viewed in 3D by right-clicking and selecting **Show 3D plot**:

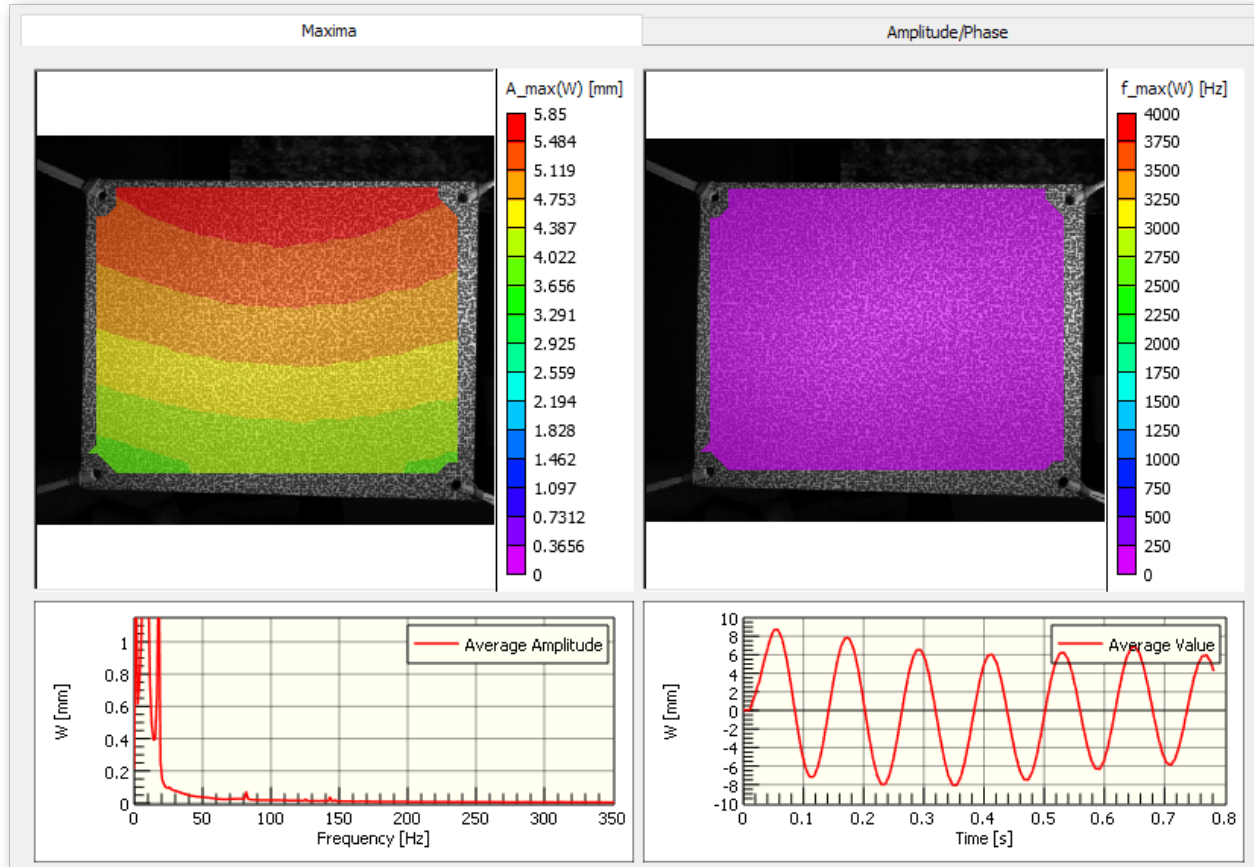

Figure 16.4: Maxima plots.

The amplitude is plotted as a contour on a 3D shape plot. The amplitude may also be visualized as a 3D shape by right-clicking and selecting **Z-axis... Contour variable**. This will show the maximum amplitude as a shape.

The bottom left plot shows the average amplitude vs. frequency for the selected variable; here, peaks are seen at 25 and 50Hz. The bottom right plot shows the average value vs. time for the selected variable.

Detailed amplitude/phase data - for a given frequency - may be viewed by clicking the Amplitude/Phase tab.

16.2.2 Amplitude/Phase Plots

The top left plot shows the amplitude, for the selected variable, at the selected frequency. The top right plot shows the relative phase for the selected variable at the selected frequency. The displayed frequency may be changed by clicking and dragging the small round marker at the top left of the Average Amplitude plot below:

Or, a value may be entered in the **F=** spin box in the **FFT tools** toolbar:

The plots will change to reflect the data for the given frequency (here, the 50Hz peak).

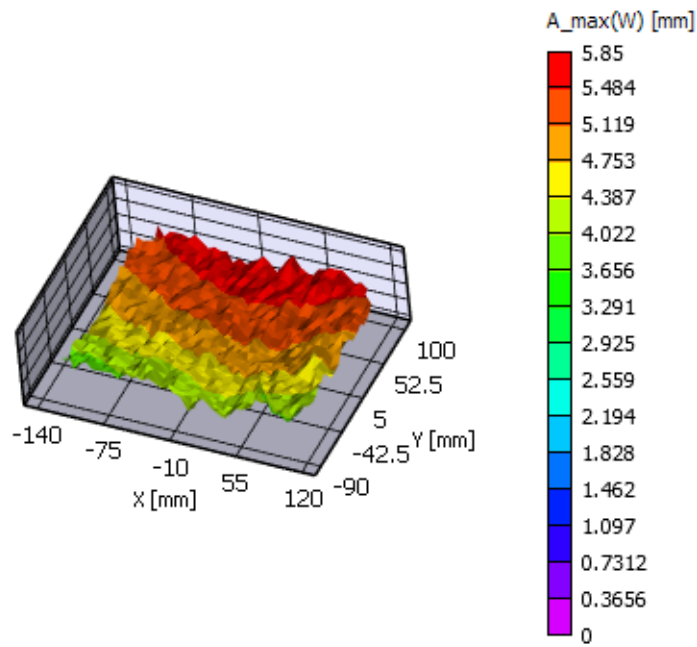

Figure 16.5: 3D plot of the maximum amplitude.

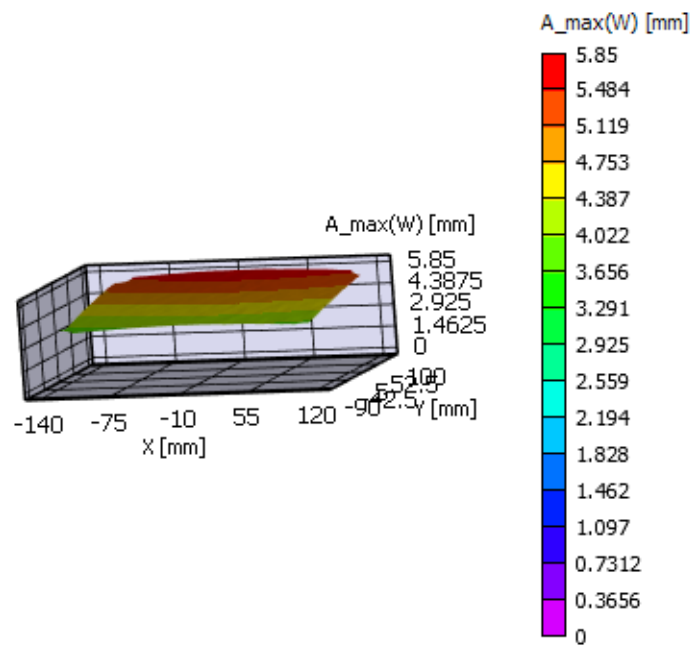

Figure 16.6: Changing the Z-axis to amplitude instead of shape.

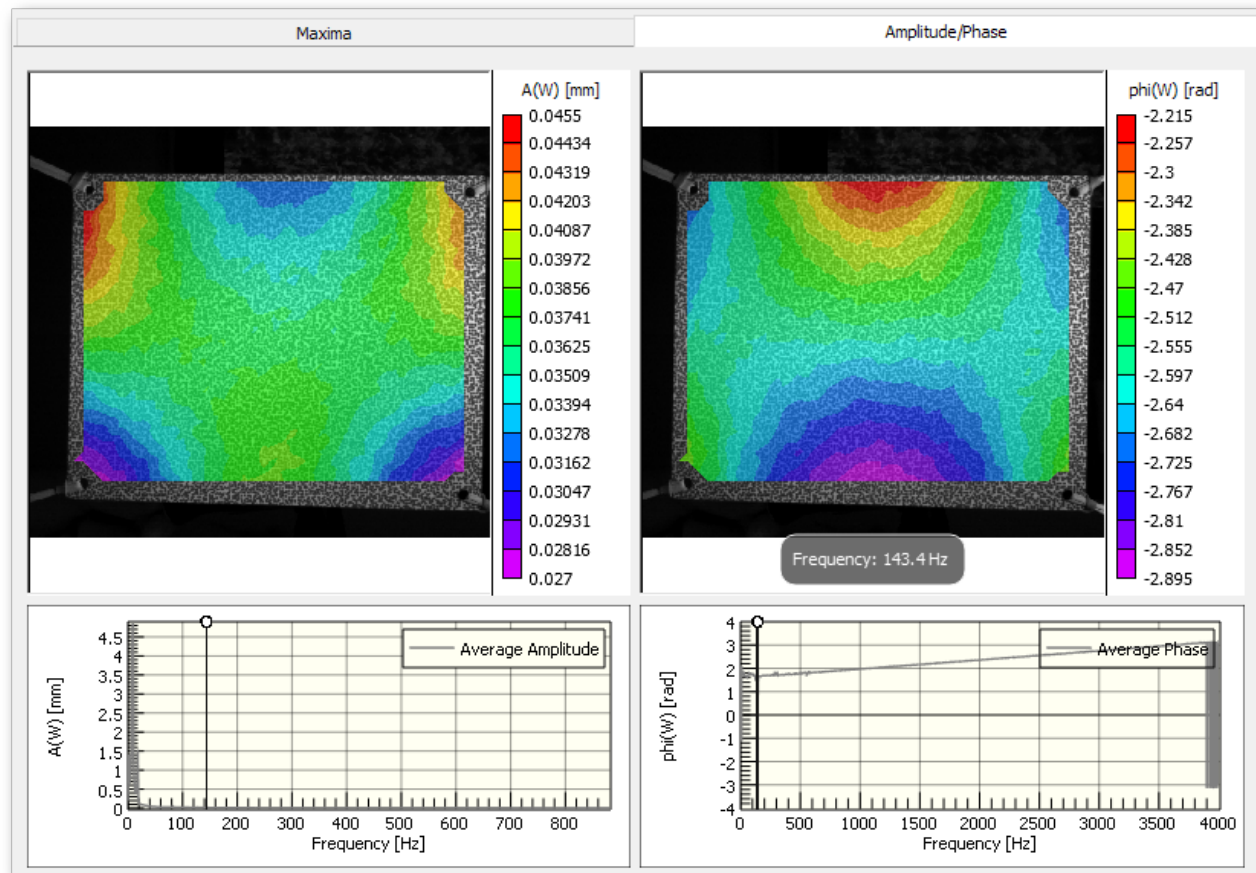

Figure 16.7: Amplitude/phase plots.

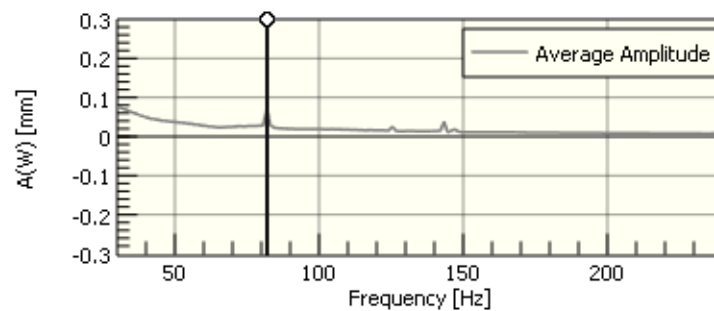

Figure 16.8: Average amplitude vs. frequency.

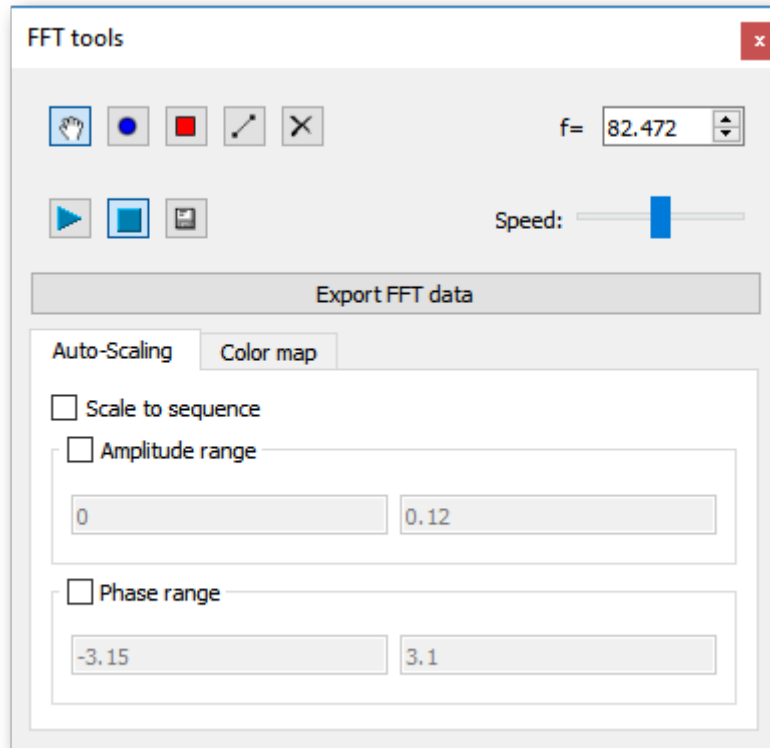

Figure 16.9: FFT tool box.

The variable may be changed by right-clicking in the plot and clicking **Variable**. A 3D plot may be viewed by right-clicking and selecting **Show 3D plot**.

In a 3D plot, **Z-axis... Contour variable** may be selected to view the amplitude at this frequency plotted as a shape. If **W** is displayed, this effectively plots the deflection shape for the frequency:

16.2.3 Scaling Options

By default, each contour plot is auto-scaled to the data in the plot. The scale may be set to the entire sequence by clicking the **Scale to sequence** checkbox in the toolbox.

A manual range may be entered by checking the **Amplitude range** or **Phase range** box and entering the desired limits.

16.2.4 Probing Individual Points

The amplitude vs. frequency and phase vs. frequency plots for a given *point* may be viewed by clicking the **add point** button (●) in the FFT tools, and then clicking in the plot. Additional lines will appear on the graphs below:

Probe points can be removed by clicking the (✕) button in the FFT tools, and then click on the point.

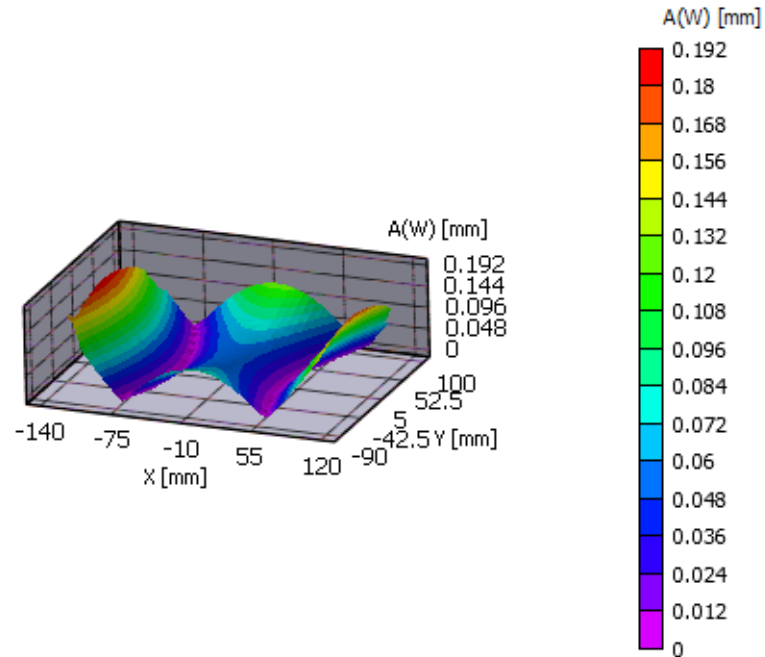

Figure 16.10: Visualizing operational deflection shapes.

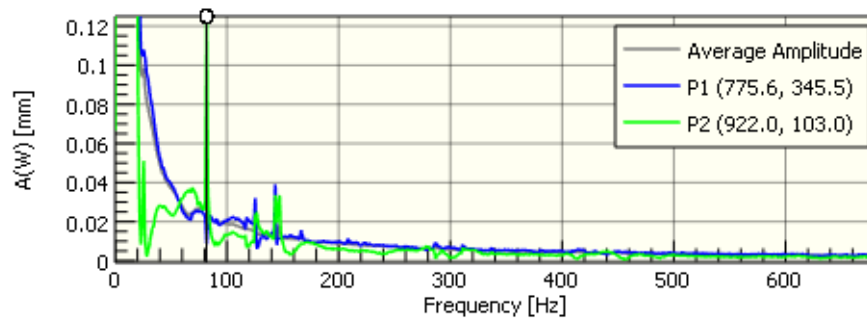



Figure 16.11: Frequency response for selected points.

A reference point (which will become the point where phase=0) may be specified by clicking the button, and then on the reference point. The extract lines in the phase plot at the lower right will re-reference to this point.

16.2.5 Probing Line Slices

Amplitude vs. frequency and phase vs. frequency plots for a given *line* may be plotted by clicking the **add line** button () in the FFT tools. The line is drawn by clicking and dragging in the plot.

Right-clicking in the graph below and choosing *Show line slices* will switch the view to the lines slice data.

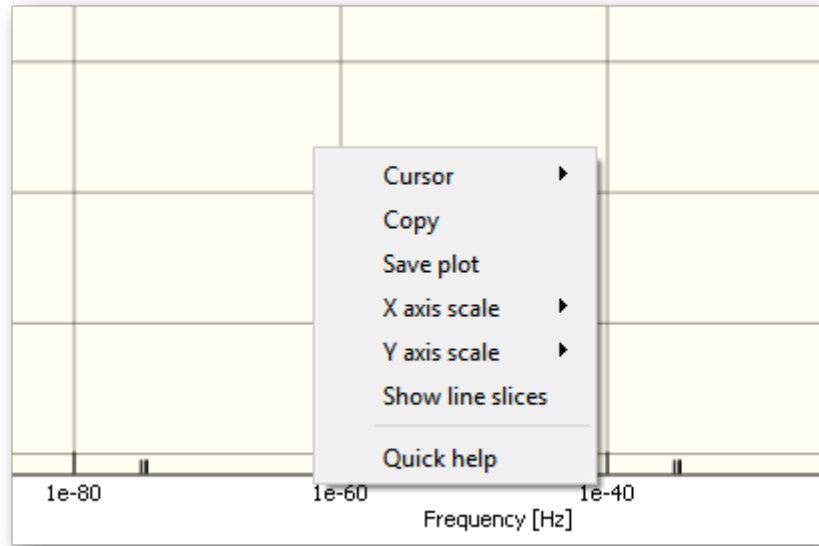

Figure 16.12: Selecting line slices for plotting.

Probe lines can be removed by clicking the button in the FFT tools, and then clicking on either endpoint.

16.2.6 Exporting FFT Data

Results from the FFT calculation can be exported either as point data for point extractions or as a complete set for the entire area analyzed. Point extractions are exported in CSV file format, while area extractions use the *Universal File Format (UFF)* developed by the *Structural Dynamics Research Corporation*.

16.2.6.1 Exporting Point Data

Extracted or average amplitude and phase data can be exported to a CSV file by clicking the **Export point data** button in the FFT Tools. This displays the dialog shown in Fig. 16.13.

The dialog offers the choice to export either the amplitude, phase, or both. The extractions, including the average value, can be selected for export in the *Points* list box. Finally, the desired variables can be selected for export in the *Variables* list box. After pressing *Ok*, a file dialog is shown to select the output file for export.

16.2.6.2 Exporting Area Data

The complete FFT data set can be exported to a UFF file by clicking the **Export area data** button in the FFT Tools. This displays the dialog shown in Fig. 16.13.

The desired variables for export can be selected in the *Variables* list box. The following *UFF* data set types are supported for export:

- Geometry (data set 2411) exports the 3D location of nodes.

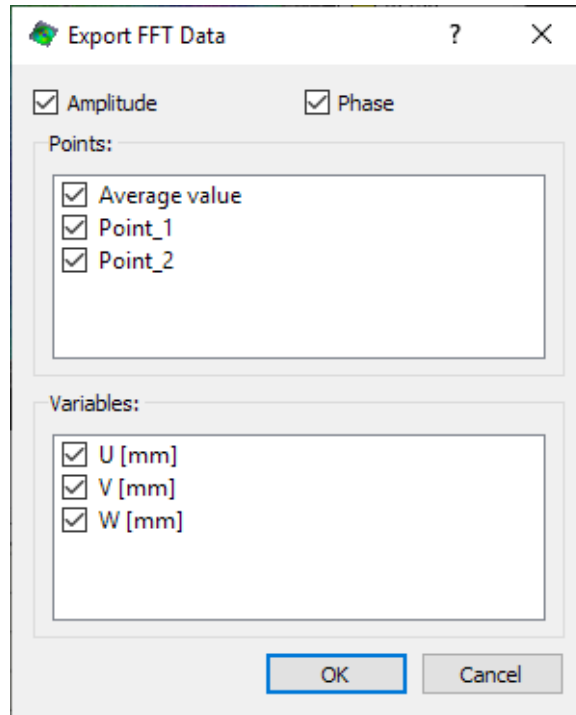

Figure 16.13: Exporting FFT Data

- Mesh (data set 2412) exports thin shell triangular elements (ID 91) for the data set. Note that there might be nodes that do not belong to triangles, particularly for larger sampling steps (see below).
- Spectrum (data set 58) exports the spectrum for each node.
- Time response (data set 58) exports the time response for each node. Note that any spatial filtering and windowing applied during FFT computation is reflected in this data.

In addition, a header (data set 151) is always exported with the data. The dialog offers the option to skip data points through increasing the *Sample step* in order to reduce file size. Note that the node IDs remain the same if this option is used.

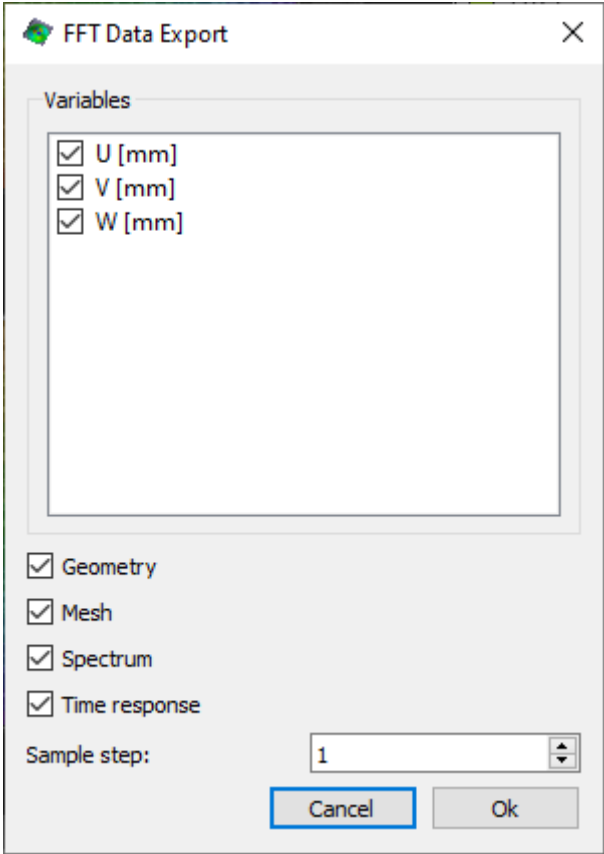

Figure 16.14: Exporting FFT Data

Chapter 17

Real-Time Analysis

To enter real-time mode, first start start Vic-Snap and start the real-time server (see Vic-Snap documentation for details). Then, start Vic-3D and select *File... Mode... Real-time 3D Analysis*. You will be prompted for a server address and port, as illustrated in Fig. 17.1.

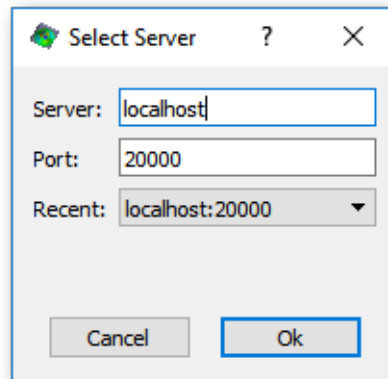

Figure 17.1: Real-time server and port settings.

With Vic-Snap running on the local PC, select *localhost*; if Vic-Snap is running remotely, you may enter the IP address of the acquisition PC. The *Port* setting should be left at the default unless there is conflict.

Vic-3D will attempt to connect to the image server; when the connection is established, a live view will appear in the workspace, and the real-time tools will be displayed, as illustrated in Fig. 17.2.

17.1 Calibration in Real-Time Mode

Calibration must be performed outside of real-time mode. There are two possible routes:

- Calibrate in Vic-Snap. If a calibration is present in Vic-Snap when you start real-time mode, it will be transferred to Vic-3D, and will appear in the Calibration tab. Or, click *Calibration* in the tool set to transfer at a later point.

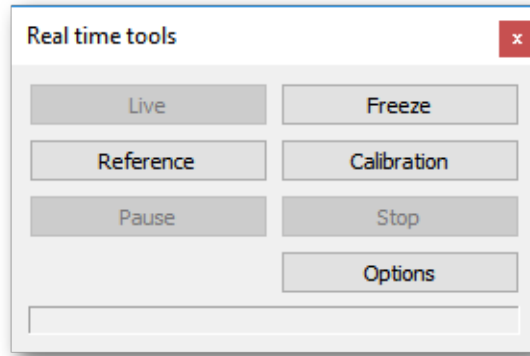

Figure 17.2: Real-time analysis tools.

- Calibrate in Vic-3D. Before beginning the test, complete a standard calibration in Vic-3d, and save a project file. After entering real-time mode, select *Calibration... Import calibration*, and select the previously saved project.

17.2 Selecting a Reference Image

To select a reference, click *Reference* in the real-time tool set. The currently displayed live image will be copied and used as reference. You may draw AOI's on this image exactly as in the standard Vic-3D mode.

17.3 Running the Analysis

To begin the real-time analysis, click the green Start Analysis button in the toolbar, or select *Data... Start analysis*. Incoming images will be analyzed and transferred in sequence as fast as the processor and transfer speed allow.

17.4 Analysis Options

[Correlation options](#) may be adjusted before or during the analysis. If the analysis is already in process, the changes will not take place until you restart the correlation.

17.5 Pausing the Analysis

In order to make changes to coordinates and contour levels, it may be helpful to pause the analysis by clicking *Pause*. The button text will change to *Resume*; click to resume.

17.6 Notes

- The data analyzed in real-time mode is displayed but not saved. To allow later processing and storage of data, be sure to store the images in Vic-Snap as usual (timed capture, manual capture, etc.)
- To obtain the best frame rates in Real-time mode, select a large step size; this will result in fewer points being analyzed and more total updates per second.
- Select a desktop PC with 2, 4, or 8 cores for maximum analysis speeds. With a fast PC and a larger step size, frame rates of 5-10 per second can be realized.
- Real-time mode is available with an optional module.

Chapter 18

Stereo Microscope Analysis

When using a stereo-microscope, regular camera models cannot accurately capture the distortions. To obtain optimal results, it is best to select the *Stereo Microscope* system type from the *File* menu. This activates the distortion correction functionality required to accurately compensate for complex distortions.

18.1 Calibrating Distortions

To calibrate a stereo-microscope, start by selecting Stereo-microscope mode in Vic-3D (File... Mode... Stereo-microscope). The following dialog appears.

The first step in calibrating the microscope distortions is to add the image pairs from the in-plane translations by clicking **Add images**. This displays a standard file dialog where the images can be selected and imported by clicking on the **Open** button.

Select a Subset size that is appropriate to the speckle image. For most situations, the Step and Coefficients settings can be left as is. Click **Run** to begin the analysis.

When analysis is complete, a message indicating success or failure will appear. Click to continue, and save the project to store the distortion correction map.

18.2 Stereo Calibration

Once the distortion correction is complete, you can add stereo grid images and calibrate as usual. The distortion order is not selectable as the distortion is corrected by the inverse mapping function.

For the *Camera* pulldown, you must select whether the magnification of the system was greater than or less than 1:1. Selecting the wrong option will result in an inverted Z-axis.

i There is no need to repeat the calibration process for multiple tests that all use the same calibration. Once the microscope has been calibrated and the project file has been saved, the calibration can either be imported (see [Section 5.6](#)) or the project can be used as a template (see [Section 3.2](#)).

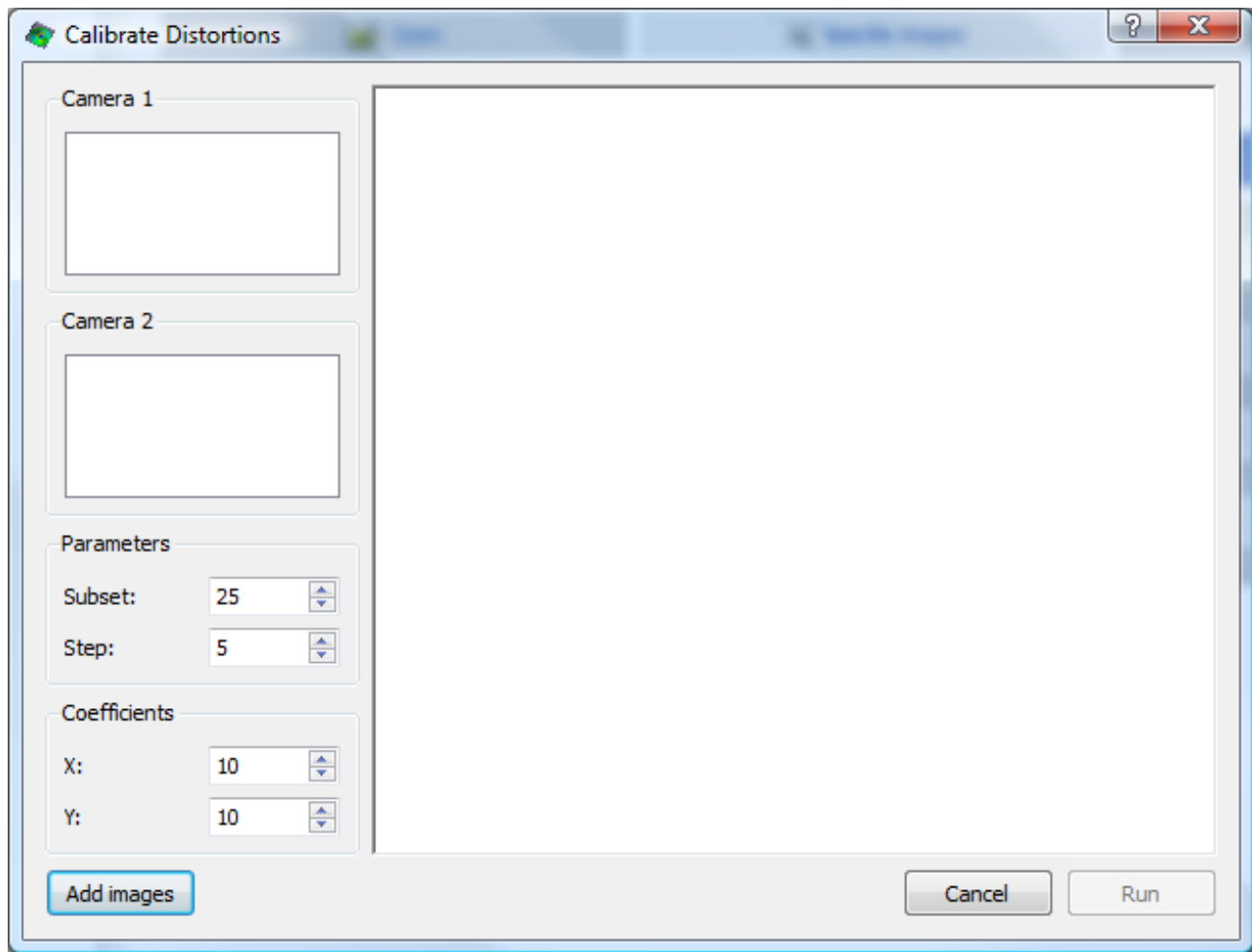

Figure 18.1: Microscope distortion calibration dialog.

18.3 Analyzing Speckle Images

Once the distortion and grid calibration is complete, you can add and analyze speckle images as usual. The data will be processed using the distortion map and corrected.



Figure 18.2: Images imported into distortion calibration dialog.

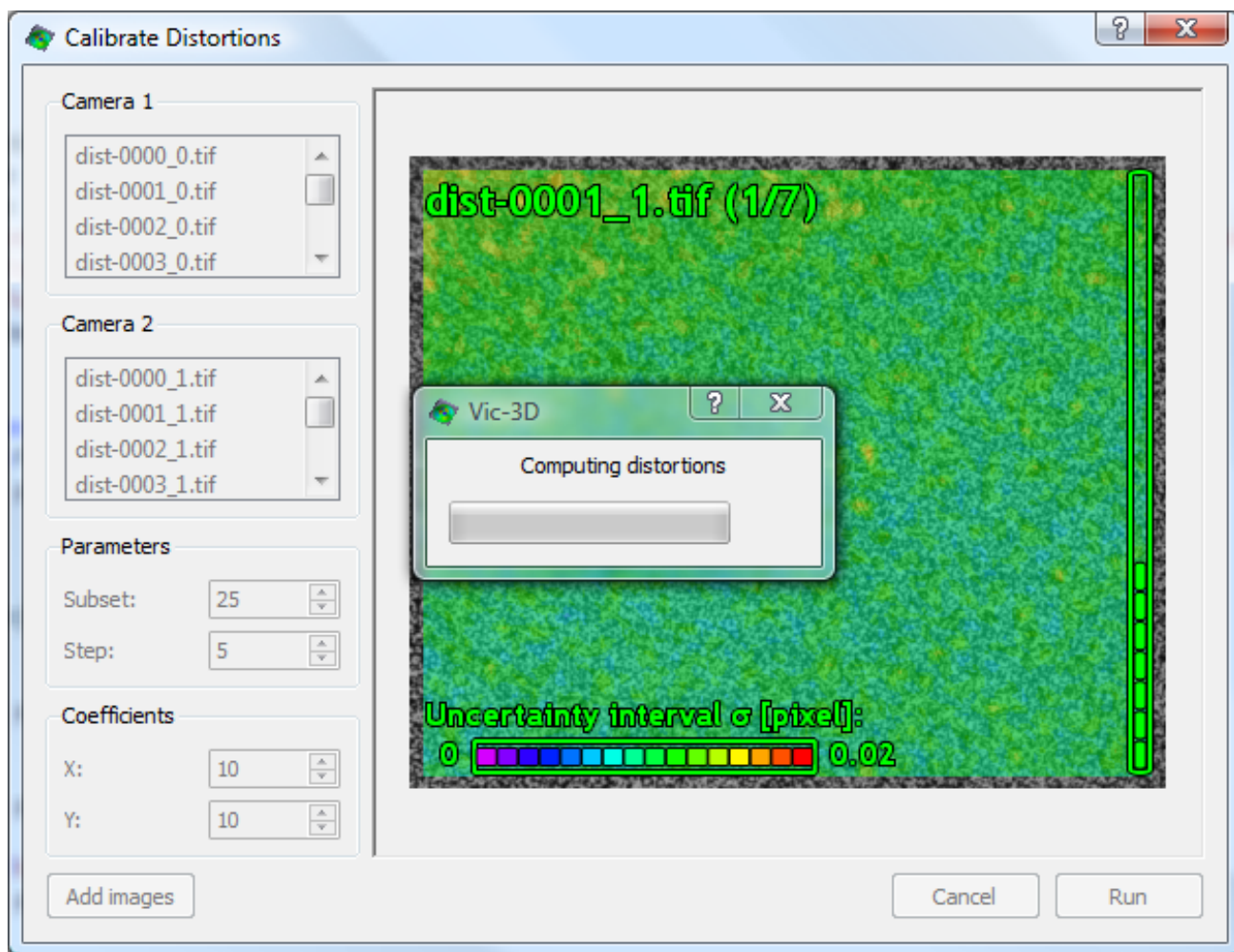

Figure 18.3: Distortion calibration dialog during analysis.

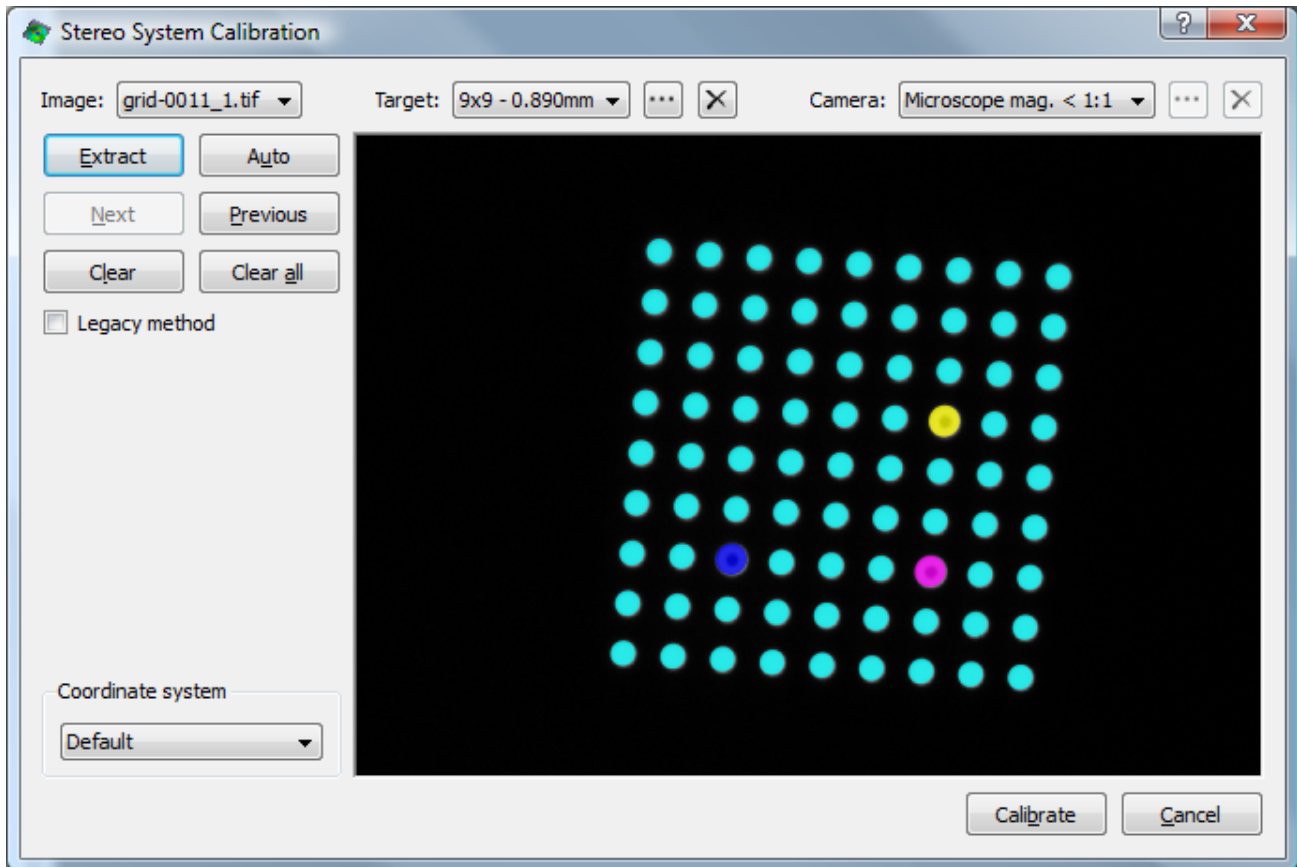

Figure 18.4: Stereo calibration dialog in stereo microscope mode.

Chapter 19

Batch Processing Mode

Vic-3D has a batch processing mode for running one or more project files without user intervention. The batch processing mode can be used by starting Vic-3D from the command line with the following arguments:

```
Vic3D -R filename1 [filename2] [...]
```

This will create or append to a log in the home directory (typically `c:\users\login_name`) folder called `Vic3D_batch_log.txt`. Alternatively, a different log file name can be specified on the command line using the `-L` switch

```
Vic3D -R filenames -L logname
```

To automatically output a report with results, one or more report templates and output files can be specified. The number of output files must match the number of project files to process.

```
Vic3D -R filenames -L logname -T templatename -O outputnames
```

In batch processing mode, a Vic-3D icon will appear in the system tray to show progress and allows cancelling the analysis. Right-clicking on the tray icon brings up a pop-up window with progress information and an option to cancel.

For each project analyzed, the log file will contain information on start and stop times, points processed, projection error, and any associated warnings or errors. If applicable, report generator output will also be logged.

Chapter 20

VicPy Python Module

The *VicPy* python module permits loading and saving of Vic-3D data files in python. This allows custom post-processing and data reduction algorithms to be implemented very quickly and efficiently. Since the python module can write results in Vic-3D's native output format, the post-processing results can then be used in Vic-3D for visualization.

20.1 Installation

The easiest method to install the VicPy method is to use the Anaconda® platform from Continuum Analytics, Inc.

1. Anaconda can be downloaded from the following link: <https://www.anaconda.com/download/>. Select the 64 bit installer for Python 3.7.
2. Install Anaconda. For *Installation Type*, it is best to select “Just Me”. Administrator rights are required if “All Users” is selected to complete the console installation steps below.
3. The “Add Anaconda to my PATH environment variable” and “Register Anaconda as my default Python 3.X” should be marked.
4. Run the Anaconda console (“Anaconda Prompt” from the Start menu). If you installed for “All Users” above, you may have to right-click and *Run as administrator*.
5. From the Anaconda console, run the command:

```
conda install -c correlatedsolutions vicpy
```

6. The VicPy module is now installed. All VicPy programs must be run from the Anaconda console.
7. If you'd like to test the module, install the examples from this link: [Python Examples](#). A short instruction file is in the ZIP.

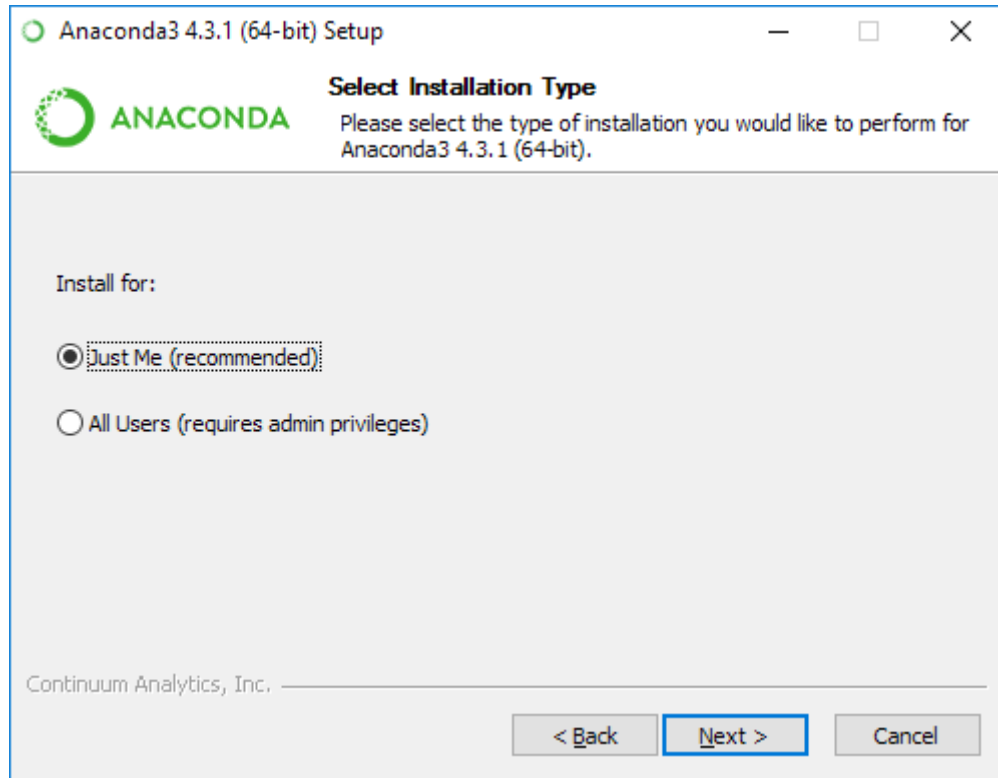

Figure 20.1: Installation type selection.

20.1.1 Running VicPy Scripts

1. If you are comfortable with the console you can simply use the console Python application to run .py and .pyw modules.
2. To run directly, you will have to associate .py and .pyw modules with the relevant applications. To do this, navigate to the file; right-click, and select **Open with...**
3. Select **More apps**.
4. Scroll all the way to the bottom, and select **Look for another app on this PC**
5. Navigate to the folder `c:\users\[your name]\anaconda3`.
6. Select `python.exe` for .py files, and `pythonw.exe` for .pyw files. (For applications with a graphical interface, PYW files will show the application without the unnecessary console window.)
7. After this, if you double click on another script, it should run directly.

For offline installation, tarballs are available at the following links:

http://www.correlatedsolutions.com/installs/vicpy-1.0-py36_0.tar.bz2

http://www.correlatedsolutions.com/installs/vicpy-1.0-py35_0.tar.bz2

http://www.correlatedsolutions.com/installs/vicpy-1.0-py34_0.tar.bz2

To install using this method, the following command can be used from an anaconda console prompt:

```
conda install vicpy-1.0-pyNN_0.tar.bz2.
```

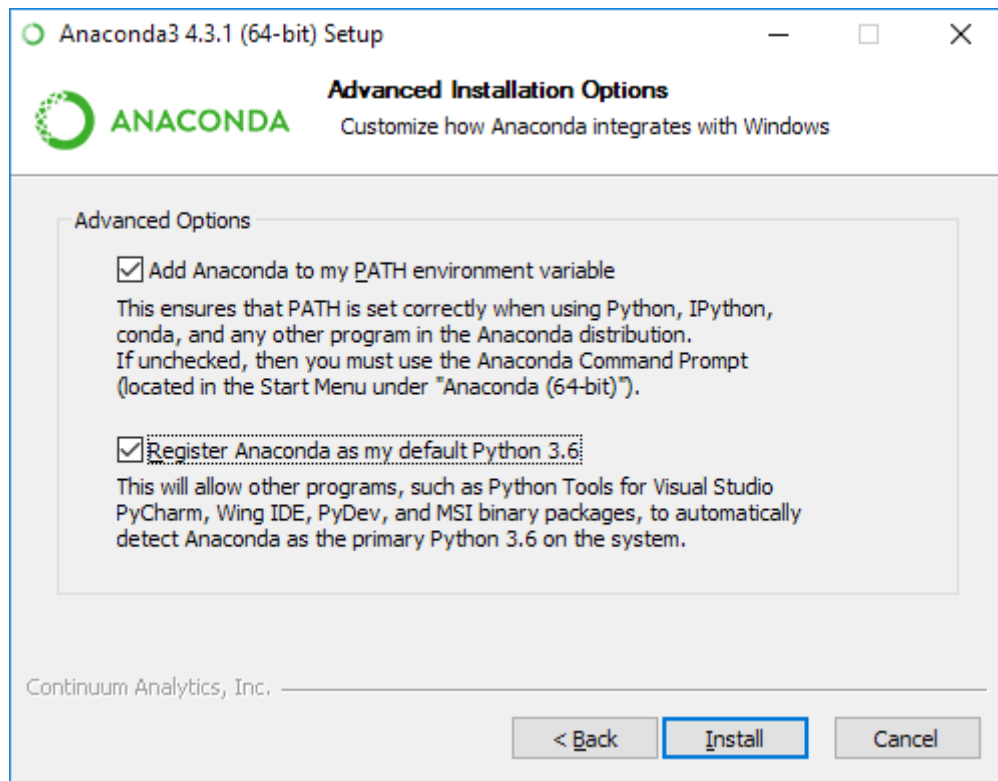

Figure 20.2: Anaconda install dialog showing both options checked.

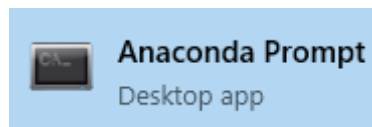

Figure 20.3: Screenshot of Anaconda prompt on start menu.

This will install the module from the tarball.

20.2 Example

To illustrate what can be done with the VicPy module, here is a very simple example that loads a data file, computes the magnitude of the displacement for all data points, and saves the data file under a new filename.

```
from VicPy import *

import math
import sys

from os import _exit as exit
```

The beginning of the script imports the VicPy module into python so that its classes become available for use. The `math` module is imported so that the square-root function can be used, the `sys` module provides access to the command-line arguments and the `exit` function is imported from the `os` module.

```

if len(sys.argv) != 3:
    print("Usage: %s infile.out outfile.out\n" % sys.argv[0])
    exit(-1)

data = VicDataSet()

if (data.load(sys.argv[1]) == False):
    print("Could not load data set\n", file=sys.stderr)
    exit(-1)

```

The program checks that an input and output file are specified on the command line and displays a usage message if not and then exits. If two arguments are given, a `VicDataSet` is created and the script attempts to read the specified input file. If an error occurs, the program displays an error message and exits.

```

# The add variable function returns the actual name
# of the variable, which might be different from the
# requested name if the variable already exists.
#
r_var = data.addVariable("D", " $\Delta$  [mm]")

var_names = ["sigma", "U", "V", "W"]

```

Here, a new variable is created for the displacement magnitude. Since all variable names in Vic data files must be unique, the name of the created variable is stored. Furthermore, a list of variables is created that is later used to find the inputs for the calculation.

```

for aoi in range(data.numData()):
    d = data.data(aoi)
    var_ids = []
    r_idx = d.varIndex(r_var);
    if r_idx < 0:
        print("Could not find variable index for resultant.")
        exit(-1)
    for var in var_names:
        idx = d.varIndex(var)
        if (idx < 0):
            print("Could not find variable %s" % var)
            exit(-1)
        var_ids.append(idx)

```

```

for i in range(d.matrixSize()):
    values = d.values(i, var_ids)
    r = 0.0
    if values[0] >= 0:
        u = values[1]
        v = values[2]
        w = values[3]
        r = math.sqrt(u * u + v * v + w * w)
    d.setValue(i, r_idx, r)

```

The script then loops over all AOIs in the data set and retrieves the variable indices for the input and output variables. Then, a second loop iterates over the data points in the AOI, computes the displacement magnitude and stores it in the result variable.

```

if data.save(sys.argv[2]) == False:
    print("Could not save the dataset\n\n")
    exit(-1)

```

Finally, the script saves the data set in the output file specified on the command line.

20.3 Class Reference

20.3.1 Class RigidTransformation

```
def apply(self, point)
```

Applies the transformation on the supplied point, both the translation and the rotation.

Args: point(tuple/list) : A tuple or a list of size 3 representing a point.

Returns: tuple/list : A tuple or list of size 3 representing the point after the applied transformation.

```
def fromDisplacement(self, data)
```

Compute a best plane fit for a data set.

Args: data(VicDataSet) : The dataset to process.

Returns: (success, residual): Returns True/False depending on the success of the fit and the residual.

```
def invert(self)
```

Invert the transformation.

```
def planeFit(self, data, bool ignoreDisp=False)
```

Compute a best plane fit for a data set.

Args: data(VicDataSet) : The dataset to process.

ignoreDisp(bool) : Whether to ignore the displacement or not. Defaults to false.

Returns: True if successful, False otherwise.

def rotation(self)

Accessor to the rotation component of the transformation object.

Returns: A Rotation object.

def setRotation(self, Rotation rot)

Set the rotation component for the transformation.

Args: rot(Rotation) : A rotation object to be used.

def setTranslation(self, point)

Set the translation component for the transformation.

Args: point(tuple/list) : Can be a tuple or list but must contain 3 elements.

def translation(self)

Accessor to the translation component of the transformation.

Returns: A tuple of the translation.

20.3.2 Class Rotation

def angles(self, bool radians=False)

Get the angles of the rotation object.

Args:

radians(bool) : Should the angles be in radians or degrees?
Defaults to false.

Returns:

Tuple : Returns a tuple of the Cardan/Bryant angles.

def apply(self, point)

Applies a transformation around the supplied point based on the angles in the rotation object.

Args: point(tuple/list) : A tuple or list, with a size of 3, that acts as a point in a coordinate system.

Returns: Depending on whether a tuple or a list was passed in, returns either a tuple or a list of the point after the applied transformation.

```
def loadIdentity(self)
```

Load an identity rotation.

```
def matrix(self)
```

Returns a 3x3 rotation matrix.

```
def setAngles(self, double alpha=0, double beta=0, double gamma=0, bool  
             radians=False)
```

Manually set or change the angles contained in the object.

Args:

alpha(double) : Rotation around x

beta(double) : Rotation around y

gamma(double) : Rotation around z

radians(bool) : Are the values in radians or degrees? Defaults to false.

```
def setMatrix(self, mat)
```

Set a 3x3 rotation matrix.

Args: mat(numpy.ndarray): 3x3 matrix

20.3.3 Class VicData

```
def asArray(self, vars)
```

Return a numpy array of the specified variables

Args: vars : List of variables.

Returns: Array of data values.

```
def atGlobalXY(self, float x, float y, vector[int] var_ids)
```

Return the values of a set of variables at a specific (global) position.

Args: `x,y(float)` : The global position to lookup.

`var_ids(vector[int])` : The variables to lookup

Returns: `bool, list` : Success status and list of the values found.

def `clear(self)`

Clears this object of all data.

def `findMaximum(self, varIdx)`

Find the maximum value for a given variable in the dataset.

Args: `varIdx(int)` : The variable to search over.

Returns: `float` : The maximum value of that variable.

def `findMinimum(self, varIdx)`

Find the minimum value for a given variable in the dataset.

Args: `varIdx(int)` : The variable to search over.

Returns: `float` : The minimum value of that variable.

def `matrixSize(self)`

Returns the size of the matrix itself.

def `numColumns(self)`

Returns the number of columns in the data matrix.

def `numRows(self)`

Returns the number of rows in the data matrix.

def `numVariables(self)`

Returns the number of variables in the data matrix.

def `setValue(self, int n, int varIdx, float value)`

Set the value of an entry in the dataset.

Args: `n(int)` : The row in the dataset to access.

`varIdx(int)` : Which variable should be changed.

`value(float)` : The value to set

def `value(self, int n, int varIdx)`

Return the value of a variable at a specific position.

Args: `n(int)` : The position to look up.

`varIdx(int)` : The index of the variable

Returns: `float` : The value of the variable at position `n`

def `values(self, int n, vector[int] var_ids)`

Return the values of a set of variables at a specific position.

Args: `n(int)` : The position to lookup.

`var_ids(vector[int])` : The variables to lookup

Returns: `list` : A list of the values found.

def `varDescription(self, int n)`

Return the description of a variable.

Args: `n(int)` : The position of the variable to look up.

Returns: `string` : The description of the variable.

def `varIndex(self, str var)`

Lookup a variable by its name and return its index.

Args: `var(string)` : The variable to search for.

Returns: `int` : Location in the array if found, else -1

def `varName(self, int n)`

Return the name of a variable.

Args: `n(int)` : The position of the variable to look up.

Returns: `string` : The name of the variable.

def `varType(self, int n)`

Return the type of a variable.

Args: `n(int)` : The position of the variable to look up.

Returns: `int` : The type of the variable.

20.3.4 Class VicDataSet

```
def addVariable(self, str varName, str varDesc)
```

Add a variable to every AOI contained in the dataset.

Args: varName(string) : Name of the variable you want to add.

varDesc(string) : Description of the variable you want to add.

Returns: actualName: The unique variable name assigned to the variable.

```
def asArray(self, vars)
```

Return a numpy array for the variables for all AOIs. Note that the triang() function returns indices into this array.

Args: vars: List of variable names.

Returns: A numpy array containing the requested data values.

```
def computeCurvature(self, int windowSize=15, bool
                      computePrincipalCurvature=True, bool reuseVars=True,
                      bool weightedFilter=True)
```

Compute the curvature over the AOIs in the datasets.

Arguments: windowSize(int) : Defaults to 15

computePrincipalCurvature(bool) : Defaults to true

reuseVars(bool) : Defaults to True

weightedFilter(bool) : Defaults to True

Returns: bool - True if successful, False otherwise

```
def computeStrain(self, int windowSize=15, str tensorType='lagrange', bool
                  computePrincipalStrain=True, bool reuseVars=True, bool
                  weightedFilter=True, bool computeTresca=False, bool
                  computeVonMises=False, bool outputGradient=False)
```

Compute the strain over the AOIs in the datasets.

Arguments: windowSize(int) : Defaults to 15

tensorType(string) : Defaults to LagrangeSTrainTensor

computePrincipalStrain(bool) : Defaults to true

reuseVars(bool) : Defaults to True

weightedFilter(bool) : Defaults to True

computeTresca(bool) : Defaults to False

computeVonMises(bool) : Defaults to False

outputGradient(bool) : Defaults to False

Returns: bool - True if successful, False otherwise

def data(self, int n)

Return a pointer to a specific VicData object.

Args: n(int) : The index of the AOI to access.

Returns: VicData : A VicData object for the AOI in the dataset.

def deformedImage(self)

Return the deformed image file name.

def exportMatV4(self, str fileName)

Save the VicDataSet as an output file in the MatV4 format.

Args: fileName(string) : The output name of the file.

Returns: bool : True if successful, otherwise false.

def load(self, str fileName)

Load a Vic-3D output file into this object.

Args: filename(string) : The file to load.

Returns: bool - True if successful, otherwise False

def loadFromData(self, bytes buffer)

Load a Vic-3D output file into this object.

Args: buffer(string) : The memory buffer data to load from.

Returns: bool - True if successful, otherwise False

```
def numData(self)
```

Return how many AOI's exist in the dataset.

```
def range(self, str var)
```

Return the range of values for a variable.

```
def referenceImage(self)
```

Return the reference image file name.

```
def save(self, str fileName)
```

Save the VicDataSet as an output file in the Vic-3D format.

Args: fileName(string) : The output name of the file.

Returns: bool : True if successful, otherwise false.

```
def setDeformedImage(self, str fileName)
```

Set the deformed image file name.

```
def setReferenceImage(self, str fileName)
```

Set the reference image file name.

```
def smooth(self, str variable, int windowSize=15, bool weighted=True)
```

```
def sum_range(self, str var0, str var1)
```

Return the range of the sum of two variables (e.g., X+U).

```
def transform(self, RigidTransformation trafo, bool displacementOnly=False)
```

Apply a transformation to the AOIs in this DataSet.

Args: trafo(RigidTransformation) :

displacementOnly(bool) : Defaults to False

```
def triang(self, int sub_sample=1)
```

Return a triangulation for the data set.

Args: sub_sample(int): Sub-sampling value for data reduction.

Returns: A n-by-3 array of triangle indices, where n is the number of triangles.

Chapter 21

Licenses

Our software includes several open source libraries that are used under a variety of different licenses.

21.1 Qt License

The [Qt library](#) is used under the terms of the GNU LGPL License, Version 3]. If you would like to receive a copy of the source code of the Qt library, please contact us at support@correlatedsolutions.com.

GNU LESSER GENERAL PUBLIC LICENSE
Version 3, 29 June 2007

Copyright (C) 2007 Free Software Foundation, Inc. <<https://fsf.org/>>
Everyone is permitted to copy and distribute verbatim copies
of this license document, but changing it is not allowed.

This version of the GNU Lesser General Public License incorporates the terms and conditions of version 3 of the GNU General Public License, supplemented by the additional permissions listed below.

0. Additional Definitions.

As used herein, "this License" refers to version 3 of the GNU Lesser General Public License, and the "GNU GPL" refers to version 3 of the GNU General Public License.

"The Library" refers to a covered work governed by this License, other than an Application or a Combined Work as defined below.

An "Application" is any work that makes use of an interface provided by the Library, but which is not otherwise based on the Library.

Defining a subclass of a class defined by the Library is deemed a mode of using an interface provided by the Library.

A "Combined Work" is a work produced by combining or linking an Application with the Library. The particular version of the Library with which the Combined Work was made is also called the "Linked Version".

The "Minimal Corresponding Source" for a Combined Work means the Corresponding Source for the Combined Work, excluding any source code for portions of the Combined Work that, considered in isolation, are based on the Application, and not on the Linked Version.

The "Corresponding Application Code" for a Combined Work means the object code and/or source code for the Application, including any data and utility programs needed for reproducing the Combined Work from the Application, but excluding the System Libraries of the Combined Work.

1. Exception to Section 3 of the GNU GPL.

You may convey a covered work under sections 3 and 4 of this License without being bound by section 3 of the GNU GPL.

2. Conveying Modified Versions.

If you modify a copy of the Library, and, in your modifications, a facility refers to a function or data to be supplied by an Application that uses the facility (other than as an argument passed when the facility is invoked), then you may convey a copy of the modified version:

- a) under this License, provided that you make a good faith effort to ensure that, in the event an Application does not supply the function or data, the facility still operates, and performs whatever part of its purpose remains meaningful, or
- b) under the GNU GPL, with none of the additional permissions of this License applicable to that copy.

3. Object Code Incorporating Material from Library Header Files.

The object code form of an Application may incorporate material from a header file that is part of the Library. You may convey such object code under terms of your choice, provided that, if the incorporated material is not limited to numerical parameters, data structure

layouts and accessors, or small macros, inline functions and templates (ten or fewer lines in length), you do both of the following:

- a) Give prominent notice with each copy of the object code that the Library is used in it and that the Library and its use are covered by this License.
- b) Accompany the object code with a copy of the GNU GPL and this license document.

4. Combined Works.

You may convey a Combined Work under terms of your choice that, taken together, effectively do not restrict modification of the portions of the Library contained in the Combined Work and reverse engineering for debugging such modifications, if you also do each of the following:

- a) Give prominent notice with each copy of the Combined Work that the Library is used in it and that the Library and its use are covered by this License.
- b) Accompany the Combined Work with a copy of the GNU GPL and this license document.
- c) For a Combined Work that displays copyright notices during execution, include the copyright notice for the Library among these notices, as well as a reference directing the user to the copies of the GNU GPL and this license document.
- d) Do one of the following:

- 0) Convey the Minimal Corresponding Source under the terms of this License, and the Corresponding Application Code in a form suitable for, and under terms that permit, the user to recombine or relink the Application with a modified version of the Linked Version to produce a modified Combined Work, in the manner specified by section 6 of the GNU GPL for conveying Corresponding Source.

- 1) Use a suitable shared library mechanism for linking with the Library. A suitable mechanism is one that (a) uses at run time a copy of the Library already present on the user's computer system, and (b) will operate properly with a modified version of the Library that is interface-compatible with the Linked

Version.

e) Provide Installation Information, but only if you would otherwise be required to provide such information under section 6 of the GNU GPL, and only to the extent that such information is necessary to install and execute a modified version of the Combined Work produced by recombining or relinking the Application with a modified version of the Linked Version. (If you use option 4d0, the Installation Information must accompany the Minimal Corresponding Source and Corresponding Application Code. If you use option 4d1, you must provide the Installation Information in the manner specified by section 6 of the GNU GPL for conveying Corresponding Source.)

5. Combined Libraries.

You may place library facilities that are a work based on the Library side by side in a single library together with other library facilities that are not Applications and are not covered by this License, and convey such a combined library under terms of your choice, if you do both of the following:

- a) Accompany the combined library with a copy of the same work based on the Library, uncombined with any other library facilities, conveyed under the terms of this License.
- b) Give prominent notice with the combined library that part of it is a work based on the Library, and explaining where to find the accompanying uncombined form of the same work.

6. Revised Versions of the GNU Lesser General Public License.

The Free Software Foundation may publish revised and/or new versions of the GNU Lesser General Public License from time to time. Such new versions will be similar in spirit to the present version, but may differ in detail to address new problems or concerns.

Each version is given a distinguishing version number. If the Library as you received it specifies that a certain numbered version of the GNU Lesser General Public License "or any later version" applies to it, you have the option of following the terms and conditions either of that published version or of any later version published by the Free Software Foundation. If the Library as you received it does not specify a version number of the GNU Lesser General Public License, you may choose any version of the GNU Lesser

General Public License ever published by the Free Software Foundation.

If the Library as you received it specifies that a proxy can decide whether future versions of the GNU Lesser General Public License shall apply, that proxy's public statement of acceptance of any version is permanent authorization for you to choose that version for the Library.

21.2 Ffmpeg License

The software includes a binary for ffmpeg used for video encoding. The included ffmpeg version was built using configuration options for LGPL (v3) licensing. If you would like to receive a copy of the source code for ffmpeg, please contact us at support@correlatedsolutions.com.

GNU LESSER GENERAL PUBLIC LICENSE Version 3, 29 June 2007

Copyright (C) 2007 Free Software Foundation, Inc. <<https://fsf.org/>>
Everyone is permitted to copy and distribute verbatim copies
of this license document, but changing it is not allowed.

This version of the GNU Lesser General Public License incorporates the terms and conditions of version 3 of the GNU General Public License, supplemented by the additional permissions listed below.

0. Additional Definitions.

As used herein, "this License" refers to version 3 of the GNU Lesser General Public License, and the "GNU GPL" refers to version 3 of the GNU General Public License.

"The Library" refers to a covered work governed by this License, other than an Application or a Combined Work as defined below.

An "Application" is any work that makes use of an interface provided by the Library, but which is not otherwise based on the Library. Defining a subclass of a class defined by the Library is deemed a mode of using an interface provided by the Library.

A "Combined Work" is a work produced by combining or linking an Application with the Library. The particular version of the Library with which the Combined Work was made is also called the "Linked Version".

The "Minimal Corresponding Source" for a Combined Work means the Corresponding Source for the Combined Work, excluding any source code for portions of the Combined Work that, considered in isolation, are based on the Application, and not on the Linked Version.

The "Corresponding Application Code" for a Combined Work means the object code and/or source code for the Application, including any data and utility programs needed for reproducing the Combined Work from the Application, but excluding the System Libraries of the Combined Work.

1. Exception to Section 3 of the GNU GPL.

You may convey a covered work under sections 3 and 4 of this License without being bound by section 3 of the GNU GPL.

2. Conveying Modified Versions.

If you modify a copy of the Library, and, in your modifications, a facility refers to a function or data to be supplied by an Application that uses the facility (other than as an argument passed when the facility is invoked), then you may convey a copy of the modified version:

- a) under this License, provided that you make a good faith effort to ensure that, in the event an Application does not supply the function or data, the facility still operates, and performs whatever part of its purpose remains meaningful, or
- b) under the GNU GPL, with none of the additional permissions of this License applicable to that copy.

3. Object Code Incorporating Material from Library Header Files.

The object code form of an Application may incorporate material from a header file that is part of the Library. You may convey such object code under terms of your choice, provided that, if the incorporated material is not limited to numerical parameters, data structure layouts and accessors, or small macros, inline functions and templates (ten or fewer lines in length), you do both of the following:

- a) Give prominent notice with each copy of the object code that the Library is used in it and that the Library and its use are covered by this License.

b) Accompany the object code with a copy of the GNU GPL and this license document.

4. Combined Works.

You may convey a Combined Work under terms of your choice that, taken together, effectively do not restrict modification of the portions of the Library contained in the Combined Work and reverse engineering for debugging such modifications, if you also do each of the following:

a) Give prominent notice with each copy of the Combined Work that the Library is used in it and that the Library and its use are covered by this License.

b) Accompany the Combined Work with a copy of the GNU GPL and this license document.

c) For a Combined Work that displays copyright notices during execution, include the copyright notice for the Library among these notices, as well as a reference directing the user to the copies of the GNU GPL and this license document.

d) Do one of the following:

0) Convey the Minimal Corresponding Source under the terms of this License, and the Corresponding Application Code in a form suitable for, and under terms that permit, the user to recombine or relink the Application with a modified version of the Linked Version to produce a modified Combined Work, in the manner specified by section 6 of the GNU GPL for conveying Corresponding Source.

1) Use a suitable shared library mechanism for linking with the Library. A suitable mechanism is one that (a) uses at run time a copy of the Library already present on the user's computer system, and (b) will operate properly with a modified version of the Library that is interface-compatible with the Linked Version.

e) Provide Installation Information, but only if you would otherwise be required to provide such information under section 6 of the GNU GPL, and only to the extent that such information is necessary to install and execute a modified version of the Combined Work produced by recombining or relinking the

Application with a modified version of the Linked Version. (If you use option 4d0, the Installation Information must accompany the Minimal Corresponding Source and Corresponding Application Code. If you use option 4d1, you must provide the Installation Information in the manner specified by section 6 of the GNU GPL for conveying Corresponding Source.)

5. Combined Libraries.

You may place library facilities that are a work based on the Library side by side in a single library together with other library facilities that are not Applications and are not covered by this License, and convey such a combined library under terms of your choice, if you do both of the following:

- a) Accompany the combined library with a copy of the same work based on the Library, uncombined with any other library facilities, conveyed under the terms of this License.
- b) Give prominent notice with the combined library that part of it is a work based on the Library, and explaining where to find the accompanying uncombined form of the same work.

6. Revised Versions of the GNU Lesser General Public License.

The Free Software Foundation may publish revised and/or new versions of the GNU Lesser General Public License from time to time. Such new versions will be similar in spirit to the present version, but may differ in detail to address new problems or concerns.

Each version is given a distinguishing version number. If the Library as you received it specifies that a certain numbered version of the GNU Lesser General Public License "or any later version" applies to it, you have the option of following the terms and conditions either of that published version or of any later version published by the Free Software Foundation. If the Library as you received it does not specify a version number of the GNU Lesser General Public License, you may choose any version of the GNU Lesser General Public License ever published by the Free Software Foundation.

If the Library as you received it specifies that a proxy can decide whether future versions of the GNU Lesser General Public License shall apply, that proxy's public statement of acceptance of any version is permanent authorization for you to choose that version for the Library.

21.3 LibTiff License

The LibTiff library is used for loading and saving images in the TIFF image format. The LibTiff library is used under the following license.

Copyright (c) 1988-1997 Sam Leffler
Copyright (c) 1991-1997 Silicon Graphics, Inc.

Permission to use, copy, modify, distribute, and sell this software and its documentation for any purpose is hereby granted without fee, provided that (i) the above copyright notices and this permission notice appear in all copies of the software and related documentation, and (ii) the names of Sam Leffler and Silicon Graphics may not be used in any advertising or publicity relating to the software without the specific, prior written permission of Sam Leffler and Silicon Graphics.

THE SOFTWARE IS PROVIDED "AS-IS" AND WITHOUT WARRANTY OF ANY KIND, EXPRESS, IMPLIED OR OTHERWISE, INCLUDING WITHOUT LIMITATION, ANY WARRANTY OF MERCHANTABILITY OR FITNESS FOR A PARTICULAR PURPOSE.

IN NO EVENT SHALL SAM LEFFLER OR SILICON GRAPHICS BE LIABLE FOR ANY SPECIAL, INCIDENTAL, INDIRECT OR CONSEQUENTIAL DAMAGES OF ANY KIND, OR ANY DAMAGES WHATSOEVER RESULTING FROM LOSS OF USE, DATA OR PROFITS, WHETHER OR NOT ADVISED OF THE POSSIBILITY OF DAMAGE, AND ON ANY THEORY OF LIABILITY, ARISING OUT OF OR IN CONNECTION WITH THE USE OR PERFORMANCE OF THIS SOFTWARE.

21.4 VTK License

VTK is an open-source toolkit licensed under the BSD license.

Copyright (c) 1993-2008 Ken Martin, Will Schroeder, Bill Lorensen
All rights reserved.

Redistribution and use in source and binary forms, with or without modification, are permitted provided that the following conditions are met:

1. Redistributions of source code must retain the above copyright notice, this list of conditions and the following disclaimer.
2. Redistributions in binary form must reproduce the above copyright notice, this list of conditions and the following disclaimer in the documentation and/or other materials provided with the distribution.

3. Neither name of Ken Martin, Will Schroeder, or Bill Lorensen nor the names of any contributors may be used to endorse or promote products derived from this software without specific prior written permission.

THIS SOFTWARE IS PROVIDED BY THE COPYRIGHT HOLDERS AND CONTRIBUTORS "AS IS" AND ANY EXPRESS OR IMPLIED WARRANTIES, INCLUDING, BUT NOT LIMITED TO, THE IMPLIED WARRANTIES OF MERCHANTABILITY AND FITNESS FOR A PARTICULAR PURPOSE ARE DISCLAIMED. IN NO EVENT SHALL THE AUTHORS OR CONTRIBUTORS BE LIABLE FOR ANY DIRECT, INDIRECT, INCIDENTAL, SPECIAL, EXEMPLARY, OR CONSEQUENTIAL DAMAGES (INCLUDING, BUT NOT LIMITED TO, PROCUREMENT OF SUBSTITUTE GOODS OR SERVICES; LOSS OF USE, DATA, OR PROFITS; OR BUSINESS INTERRUPTION) HOWEVER CAUSED AND ON ANY THEORY OF LIABILITY, WHETHER IN CONTRACT, STRICT LIABILITY, OR TORT (INCLUDING NEGLIGENCE OR OTHERWISE) ARISING IN ANY WAY OUT OF THE USE OF THIS SOFTWARE, EVEN IF ADVISED OF THE POSSIBILITY OF SUCH DAMAGE.

21.5 ZLib License

```
/* zlib.h -- interface of the 'zlib' general purpose compression library
   version 1.2.11, January 15th, 2017
```

Copyright (C) 1995-2017 Jean-loup Gailly and Mark Adler

This software is provided 'as-is', without any express or implied warranty. In no event will the authors be held liable for any damages arising from the use of this software.

Permission is granted to anyone to use this software for any purpose, including commercial applications, and to alter it and redistribute it freely, subject to the following restrictions:

1. The origin of this software must not be misrepresented; you must not claim that you wrote the original software. If you use this software in a product, an acknowledgment in the product documentation would be appreciated but is not required.
2. Altered source versions must be plainly marked as such, and must not be misrepresented as being the original software.
3. This notice may not be removed or altered from any source distribution.

Jean-loup Gailly
jloup@gzip.org

Mark Adler
madler@alumni.caltech.edu

```
*/
```

21.6 MuParser License

Copyright (C) 2013 Ingo Berg

Permission is hereby granted, free of charge, to any person obtaining a copy of this software and associated documentation files (the "Software"), to deal in the Software without restriction, including without limitation the rights to use, copy, modify, merge, publish, distribute, sublicense, and/or sell copies of the Software, and to permit persons to whom the Software is furnished to do so, subject to the following conditions:

The above copyright notice and this permission notice shall be included in all copies or substantial portions of the Software.

THE SOFTWARE IS PROVIDED "AS IS", WITHOUT WARRANTY OF ANY KIND, EXPRESS OR IMPLIED, INCLUDING BUT NOT LIMITED TO THE WARRANTIES OF MERCHANTABILITY, FITNESS FOR A PARTICULAR PURPOSE AND NONINFRINGEMENT. IN NO EVENT SHALL THE AUTHORS OR COPYRIGHT HOLDERS BE LIABLE FOR ANY CLAIM, DAMAGES OR OTHER LIABILITY, WHETHER IN AN ACTION OF CONTRACT, TORT OR OTHERWISE, ARISING FROM, OUT OF OR IN CONNECTION WITH THE SOFTWARE OR THE USE OR OTHER DEALINGS IN THE SOFTWARE.